

Thermoplastic conveyor chains	
Materials .....	2
Thermoplastic straight running chains - Single hinge .....	3
Thermoplastic straight running chains - Double hinge .....	4
Thermoplastic sideflexing chains .....	5
Thermoplastic sideflexing chains on magnetic tracks .....	7
Thermoplastic sideflexing chains .....	8
Vacuum thermoplastic straight running chains/ - Single hinge .....	9
Straight running chains with thermoplastic Top plates .....	10
"1843" Sideflexing chains with thermoplastic Top plates .....	12
Thermoplastic straight running chains with rubber inserts - Single/Double hinge .....	13
Thermoplastic sideflexing chains with rubber inserts .....	14
"1873" Sideflexing chains with thermoplastic top plates and rubber inserts .....	16
Double hinge straight running chains - with low noise accumulation rollers .....	17
Straight running chains - Heavy duty single hinge - with low noise accumulation rollers .....	18
Sideflexing chains - with low noise accumulation rollers .....	19
Flex thermoplastic chains .....	20
Case conveyor chains .....	22
Plastic corrosion resistance table .....	24
Metal conveyor chains	
Materials .....	24
Straight running chains - Single hinge .....	25
"Mignon" straight running chains - Single hinge .....	31
Straight running chains - Double hinge .....	32
Sideflexing hinged slat chains .....	33
Sideflexing hinged slat chains for magnetic system .....	37
Straight running chains with rubber inserts for inclined conveyors - Single hinge .....	38
Sideflexing hinged slat chains with rubber inserts for inclined conveyors .....	39
"1864" Straight running plate top chains .....	40
"1874" Sideflexing plate top chains .....	41
Sprockets .....	42
Idlers .....	46
Thermoplastic bearing units	
Thermoplastic bearing units .....	47
Stainless steel bearing units .....	58
Support bases .....	64
Threated tube ends .....	65
Side mounting top brackets .....	66
Side mounting top brackets/ Connecting joints/ Support heads .....	67
Support heads/ Split collars .....	68
Accessories/ Return profile support .....	69
Return profile support/ Return accessories/ Chain return components .....	70
Chain return components/ Return profile support .....	71
Rollers/ Transfers .....	72
Roller guides/ Adjustable brackets .....	75
Supports/ Support spacer/ Knobs .....	79
Knobs/ Heads .....	80
Heads/ Adjusting rods .....	81
Clamps for round profile guides .....	82
Clamps for "MC" guides .....	84
Clamps for conical side guides .....	88
Extra side guides .....	89
Guides/ Accessories .....	90
Drip tray supports/ Cross block and photocell accessories .....	91
Cross block and photocell accessories/ Frame system .....	92
Frame accessories .....	94
Frame accessories/ Handles .....	95
Handles/ Hinges .....	96
Regulate greaser/ Guides for bottling and packaging .....	97
Guides for bottling and packaging/ Profiles of bevel channel .....	100
Roller chain guides .....	101
Roller chain guides/ Flat belt, V-belt and cable guides .....	105
Steel profile .....	106
Feet	
Fixed feet .....	107
Articulated feet - base in reinforced polyamide .....	108
Stainless steel accessories .....	109
Timing belts	
Megapower PU endless timing belts .....	113
Isoran rubber endless timing belts .....	115

The plastic slat-top chains from ScanBelt are of the highest quality and are long-lasting. These are supplied in a variety of materials, for both standard and specific applications. We are constantly developing chains in close contact with major OEMs and end users in the market. If you require chains that are not displayed in the following pages, please contact us for a discussion about the correct solution for your application.

We are currently supplying thermoplastic slat-top chains to all kinds of industries that have conveying applications, such as packaging, handling/ labelling, bakery, meat, fish and poultry, bottling and canning applications in the brewery sector as well as numerous other conveying tasks.

## Materials

	<p><b>D</b></p> <p>ACETAL RESIN</p> <p>The acetal resin offers very good mechanical specifications, excellent wear resistance and a low coefficient of friction. Used in the manufacturing of plates for flat top chains, it is an economical alternative to our LFA material. FDA (Food Drug Administration) approved for direct contact with food.</p> <p>Working temperatures: -40° C / + 80° C (dry environment) -40° C / + 65° C (wet environment)</p> <p>Colour: grey</p>
<p><b>LFA</b> <b>WLF/WAF</b></p> <p>LOW FRICTION ACETAL RESIN</p> <p>This material has a low coefficient of friction, high wear resistance and excellent resistance to chain tension. It is recommended for high load, high speed applications. FDA (Food and Drug Administration) approved for direct contact with food.</p> <p>Working temperatures: -40° C / + 80° C (dry environment) -40° C / + 65° C (wet environment)</p> <p>LFA Colour: light brown, green-blue / WLF colour: white</p>	<p><b>SP</b></p> <p>SUPER PERFORMANCE ACETAL RESIN</p> <p>The Super performance resin has a lower coefficient of friction than LFA material. Plate wear and chain elongation are reduced; it is suitable for high speed applications and reduced lubrication. FDA (Food Drug Administration) approved for direct contact with food.</p> <p>Working temperatures: -40° C / + 80° C (dry environment) -40° C / + 65° C (wet environment)</p> <p>Colour: dark grey</p>
<p><b>WR</b></p> <p>WEAR RESISTANT RESIN</p> <p>It is especially wear resistant in abrasive environment and it is suitable for conveying glass, mechanical components, sand, etc.</p> <p>Working temperatures: -40° C / + 80° C (dry environment) -40° C / + 65° C (wet environment)</p> <p>Colour: light grey</p>	<p><b>AS</b></p> <p>ANTISTATIC ACETAL RESIN</p> <p>This material offers great protection against static electrical charges. It is ideal for explosive atmosphere and where an electrostatic force may cause product instability.</p> <p>Working temperatures: -40° C / + 80° C (dry environment) -40° C / + 65° C (wet environment)</p> <p>Colour: black</p>
<p><b>PPB</b></p> <p>CHEMICAL RESISTANT REINFORCED POLYPROPYLENE</p> <p>This improved polypropylene has acid and corrosion resistance characteristics; it is specially recommended when a chain is exposed to chemical agents.</p> <p>Working temperatures: +5° C / + 105° C (dry environment) +5° C / + 105° C (wet environment)</p> <p>Colour: white</p>	<p><b>PBT</b></p> <p>EXTRA PERFORMANCE POLYESTER RESIN (Available upon request)</p> <p>It has a very low coefficient of friction and offers an excellent wear resistance. Plate wear and pitch elongation are reduced. It is specially developed for high speed and dry running applications.</p> <p>Working temperatures: -40° C / +125° C Colour: green</p>

# Thermoplastic straight running chains – Single hinge

820 Series

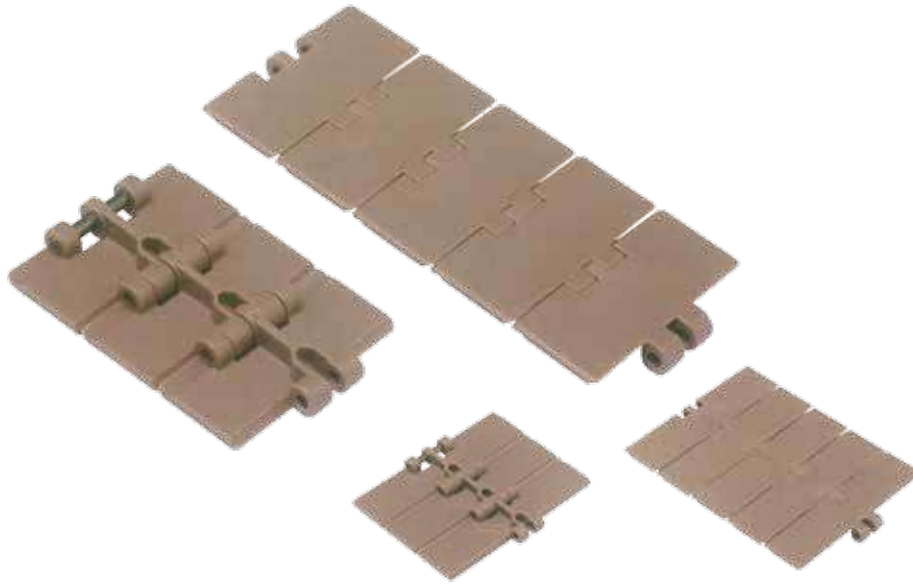

Chain Ref.	Material	Width L mm	Thickness S mm	Height H mm	Weight Kg/m
820 - K 250	See page 2	63,5	4	9,5	0,73
820 - K 325		82,5			0,83
820 - K 343		87,0			0,85
820 - K 350		88,9			0,87
820 - K 400		101,6			0,95
820 - K 450		114,3			1,03
820 - K 600		152,4			1,25
820 - K 750		190,5			1,47

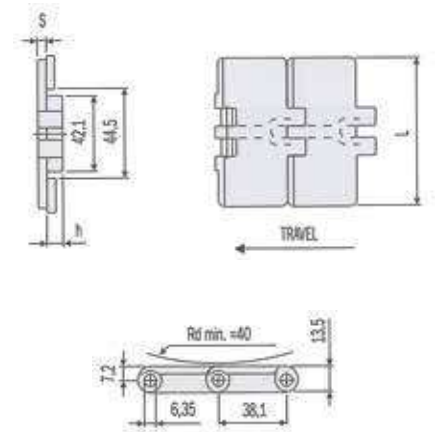

831 Series

Chain Ref.	Material	Width L mm	Thickness S mm	Height H mm	Weight Kg/m
831 - K 325	See page 2	82,5	4,8	8,7	1,00
831 - K 400		101,6			1,15
831 - K 450		114,3			1,24
831 - K 600		152,4			1,51
831 - K 750		190,5			1,76



- Standard shipping lengths = 80 pitches = 10 feet = 3,048 metres.
- These chains can be supplied either with pins in austenitic stainless steel, work hardened, highly wear resistant or in thermoplastic resin.



Designation example  
**LFA** — Mat + Colour  
**831** — Chain type  
**K 325** — Chain Width

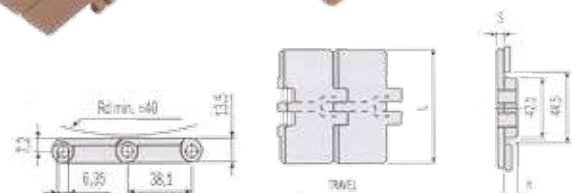

821 Series

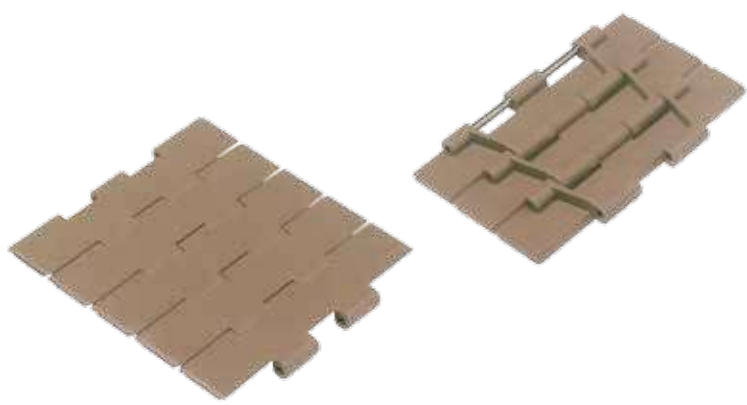

Designation example  
 LFA — Mat + Colour  
 821 — Chain type  
 K 750 — Chain Width

Chain Ref.	Material	Width L mm	Weight Kg/m
821 - K 750	See page 2	190,5	2,50
821 - K 1000		254,0	2,95
821 - K 1200		304,8	3,25

- Standard shipping lengths = 80 pitches = 10 feet = 3,048 metres.
- These chains can be supplied either with pins in austenitic stainless steel, work hardened, highly wear resistant or in thermoplastic resin.

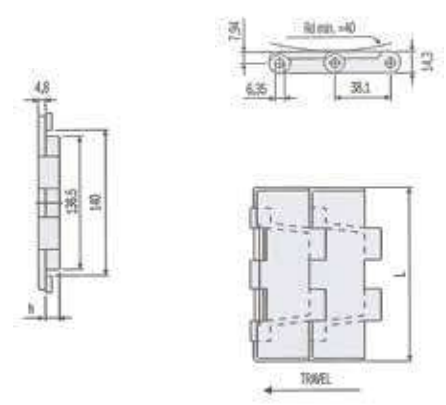

Thermoplastic straight running chains – Double hinge

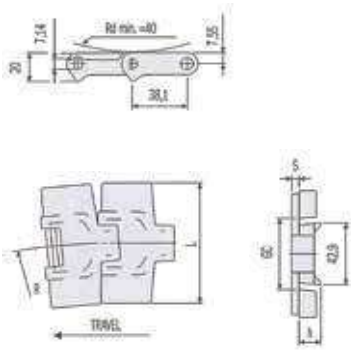

880 Series  
Bevel

Chain Ref.	Material	Width L mm	Thickness S mm	Height H mm	Min. Radius R mm	GC Straight mm	GC Sidefl. mm	Weight Kg/m
880 - K 325	See page 2	82,5	4	16	400	44,5	41,4	0,89
880 - K 350		88,9						0,91
880 - K 450		114,3						1,04
880 - K 750		190,5						1,40

879 Series

Chain Ref.	Material	Width L mm	Thickness S mm	Height H mm	Min. Radius R mm	GC Straight mm	GC Sidefl. mm	Weight Kg/m
879 - K 325	See page 2	82,5	4,8	15,2	400	44,5	41,4	0,93
879 - K 450		114,5	4,8	15,2	400	44,5	41,4	1,10

### Designation example

LFA — Mat + Colour  
879 TAB — Chain type  
K 325 — Chain Width

879 TAB  
Series

Chain Ref.	Material	Width L mm.	Thickness S mm.	G mm.	Height H mm.	Min. Radius R mm.	GC Straight mm.	GC Sidefl. mm.	Weight Kg./m.
879 TAB - K 325	See page 2	82,5	4,8	11	15,2	400	46	44,2	0,98
879 TAB - K 450		114,3	4,8	11	15,2	400	46	44,2	1,14

- Standard shipping lengths = 80 pitches = 10 feet = 3,048 metres.
- These chains can be supplied either with pins in austenitic stainless steel, work hardened, highly wear resistant or in thermoplastic resin.

**880 TAB Series**

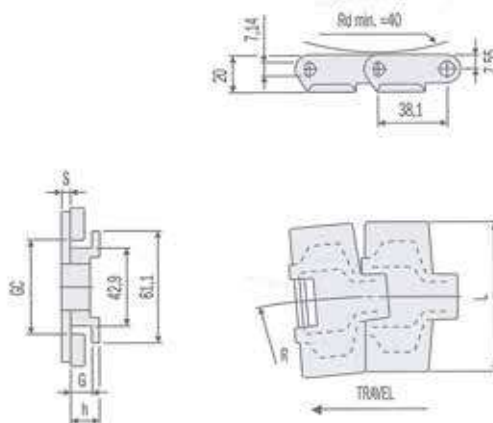

Chain Ref.	Material	Width L mm.	Thickness S mm.	G mm.	Height H mm.	Min. Radius R mm.	GC Straight mm.	GC Sidefl. mm.	Weight Kg./m.
880TAB - K 250	See page 2	63,5	4	11,5	16	400	46	44,2	0,80
880TAB - K 325		82,5							0,94
880TAB - K 343		87,0							0,99
880TAB - K 350		88,9							1,01
880TAB - K 450		114,3							1,08
880TAB - K 600		152,4							1,28
880TAB - K 750		190,5							1,48

**880 BO Series**

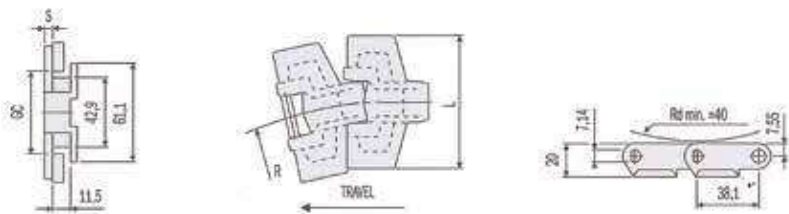
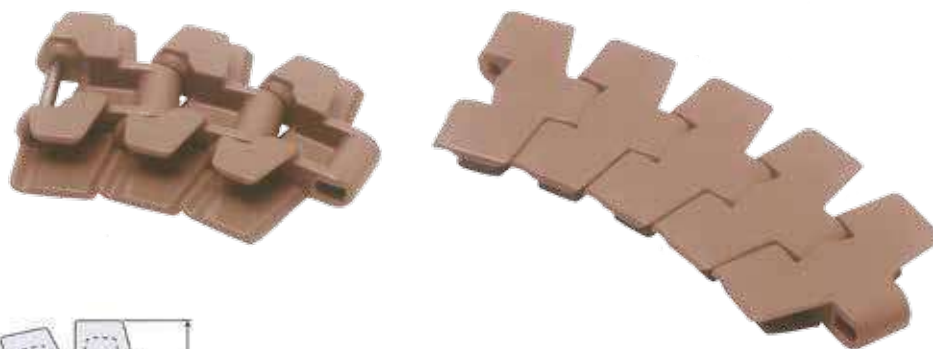

Chain Ref.	Material	Width L mm.	Thickness S mm.	Min. Radius R mm.	GC Straight mm.	GC Sidefl. mm.	Weight Kg./m.
880 BO - K 325	See page 2	82,5	4	190	46	44,2	0,96
880 BO - K 450		114,3	4	190	46	44,2	1,11

Thermoplastic sideflexing chains

- Standard shipping lengths = 80 pitches = 10 feet = 3,048 metres.
- These chains can be supplied either with pins in austenitic stainless steel, work hardened, highly wear resistant or in thermoplastic resin.

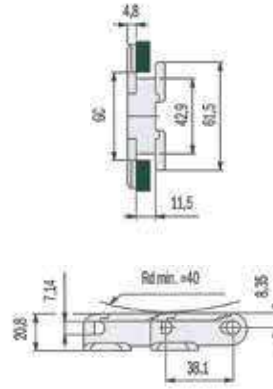

878 BO Series

Chain Ref.	Material	Width L mm.	Min. Radius R mm.	GC Straight mm.	GC Sidefl. mm.	Weight Kg./m.
878 BO - K 325	See page 2	82,5	190	46	44,2	1,08
878 BO - K 450		114,3	190	46	44,2	1,20

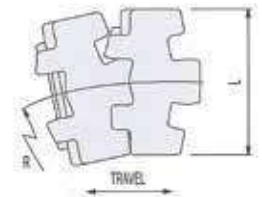

# Thermoplastic sideflexing chains on magnetic tracks

879 M Series

Chain Ref.	Material	Width L mm.	Thickness S mm.	Min. Radius R mm.	GC Straight mm.	GC Sidefl. mm.	Weight Kg./m.
879 M - K 325	See page 2	82,5	4,8	457	44	44	1,08

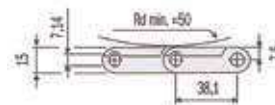
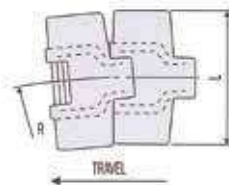
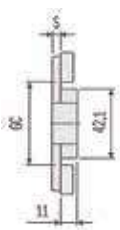
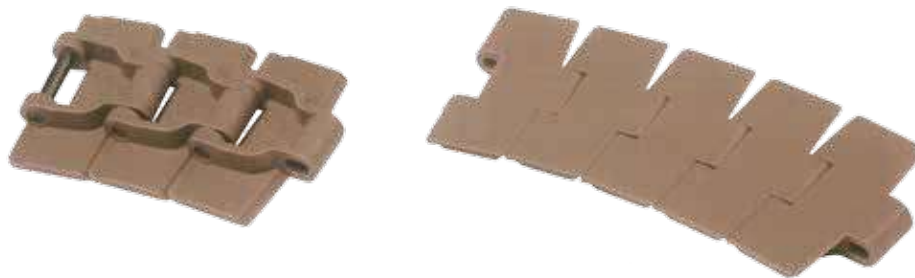

880 M Series

### Designation example

- LFA — Mat + Colour
- 880 M — Chain type
- K 325 — Chain Width

Chain Ref.	Material	Width L mm.	Thickness S mm.	Min. Radius R mm.	GC Straight mm.	GC Sidefl. mm.	Weight Kg./m.
880 M - K 325	See page 2	82,5	4	457	44	44	1,03
880 M - K 330		83,8					1,03
880 M - K 450		114,3					1,16

- Standard shipping lengths = 80 pitches = 10 feet = 3,048 metres.
- These chains can be supplied either with pins in austenitic stainless steel, work hardened, highly wear resistant or in thermoplastic resin.

**882 Series**



Designation example  
**LFA** — Mat + Colour  
**882** — Chain type  
**K 450** — Chain Width

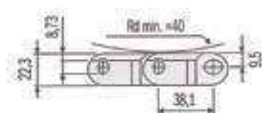
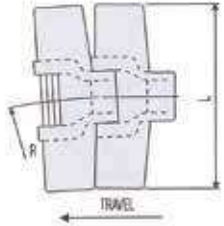

Chain Ref.	Material	Width L mm.	Min. Radius R mm.	GC Straight mm.	GC Sidefl. mm.	Weight Kg./m.
882 - K 450	See page 2	114,3	610	61,9	58	1,94
882 - K 750		190,5				2,38
882 - K 1000		254,0				2,83
882 - K 1200		304,8				2,75

**882 TAB Series**

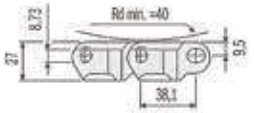
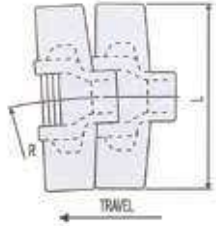
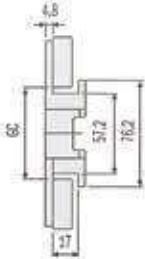

Chain Ref.	Material	Width L mm.	Min. Radius R mm.	GC Straight mm.	GC Sidefl. mm.	Weight Kg./m.
882 TAB - K 450	See page 2	114,3	610	60	58	1,98
882 TAB - K 750		190,5				2,43
882 TAB - K 1000		254,0				2,87
882 TAB - K 1200		304,8				3,41

Thermoplastic sideflexing chains

- Standard shipping lengths = 80 pitches = 10 feet = 3,048 metres.  
 - These chains can be supplied either with pins in austenitic stainless steel, work hardened, highly wear resistant or in thermoplastic resin.





# Vacuum thermoplastic straight running chains/ - Single hinge

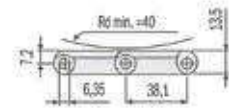
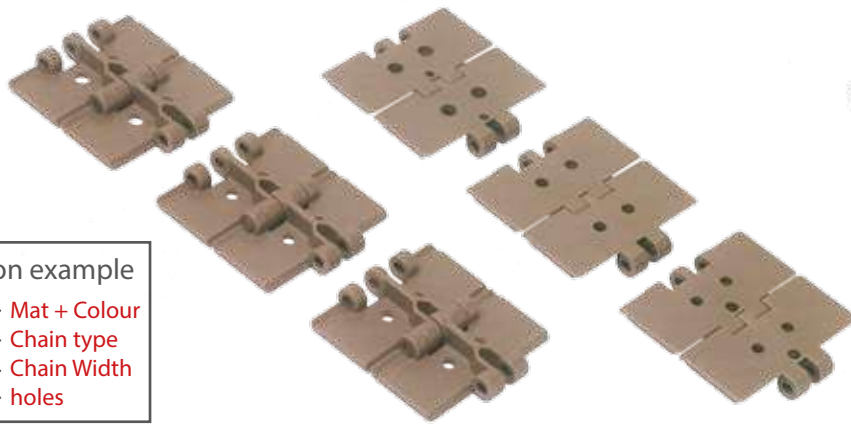

820 Series  
Vacuum

### Designation example

LFA — Mat + Colour  
820 — Chain type  
K 325 — Chain Width  
Vacum b2 — holes

Chain Ref.	Material	Width L mm.	Ø Bore d1 mm.	Ø Bore d2 mm.	IA* mm.	Weight Kg./m.
<b>B2 Two bores</b>						
820 - K 325 B2	See page 2	82,5	6,5	-	19	0,83
820 - K 350 B2		88,9	4,0	-	45	0,87
820 - K 450 B2 H30		114,3	8,0	-	30	1,03
820 - K 450 B2 H50		114,3	8,0	-	50	1,03
<b>B2 Three bores</b>						
820 - K 325 B3		82,5	7,9	4,4	20	0,83

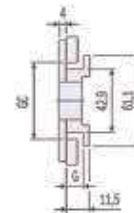
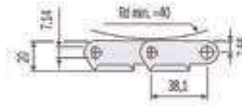
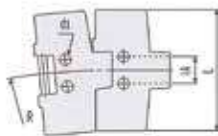
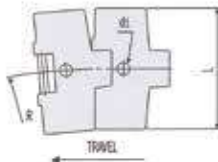
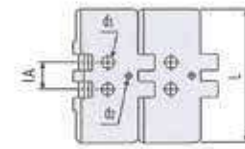
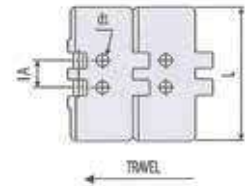

880 TAB  
Series  
Vacuum

Chain Ref.	Material	Width L mm.	Ø Bore d1 mm.	IA*	Min. Radius R mm.	GC Straight mm.	GC Sidefl. mm.	Weight Kg./m.
<b>B1 one bore</b>								
880 TAB - K 325 B1		82,5	5/6/6,5/8/9,5/10	-	457	46	44,2	0,94
<b>B2 two bore</b>								
880 TAB - K 335 B2	See page 2	82,5	6	24	457	46	44,2	0,94
880 TAB - K 335 B2		82,5	8	20	457	46	44,2	0,94
880 TAB - K 450 B2		114,3	6	24	610	46	44,2	1,08

\*IA = Distance between centres.

- Standard shipping lengths = 80 pitches = 10 feet = 3,048 metres.

- These chains can be supplied either with pins in austenitic stainless steel, work hardened, highly wear resistant or in thermoplastic resin.

**843 Series**

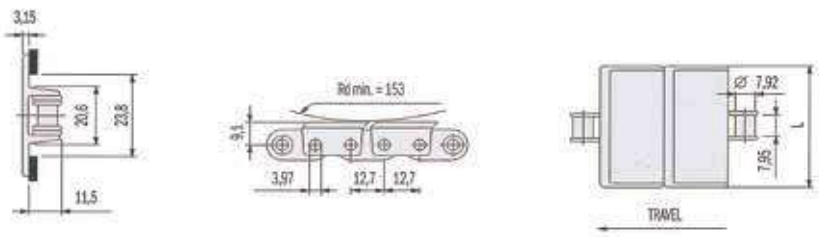
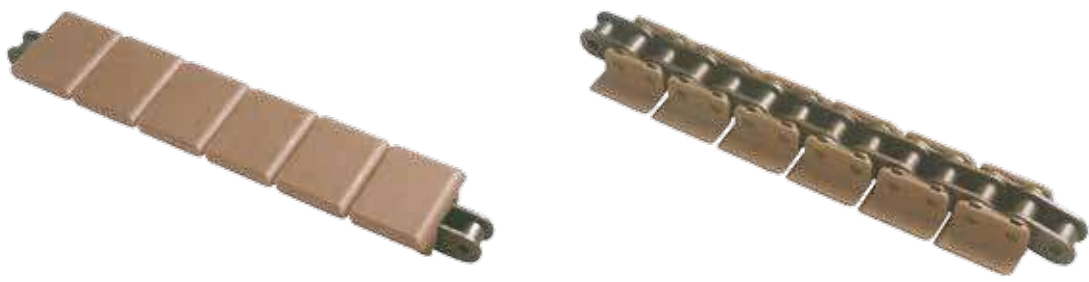

Chain Ref.	Material		Width L mm.	Weight Kg./m.
	Base chain	Top plate		
843 - K 138	Steel	See page 2	34,9	0,83
843 - K 144*			36,5	0,84
843 - K 200			50,8	0,89
843 - K 275*			70,0	0,92
843 - K 325*			82,5	1,03

Chain Ref.	Material		Width L mm.	Weight Kg./m.
	Base chain	Top plate		
843 SS - K 138	Stainkess	See page 2	34,9	0,83
843 SS - K 144*			36,5	0,84
843 SS - K 200	50,8		0,89	
843 SS - K 275*	70,0		0,92	
843 SS - K 325*	82,5		1,03	

**845 Series**



**Designation example**  
 LFA — Mat + Colour  
 845 — Chain type  
 K 118 — Chain Width

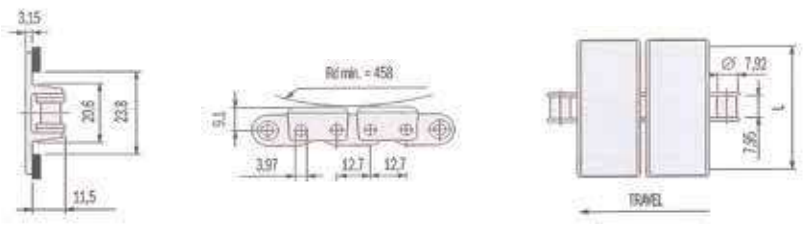

Chain Ref.	Material		Width L mm.	Weight Kg./m.
	Base chain	Top plate		
845 - K 118*	Steel	See page 2	28,6	0,85
845 - K 138			34,9	0,89
845 - K 200*			50,8	0,99

Chain Ref.	Material		Width L mm.	Weight Kg./m.
	Base chain	Top plate		
845 SS - K 118*	Stainless	See page 2	28,6	0,85
845 SS - K 138*			34,9	0,89
843 SS - K 200*			50,8	0,99

Straight running chains with thermoplastic Top Plate

\*Size produced only upon request.  
 - Standard shipping lengths = 240 pitches = 10 feet = 3,048 metres.

# Straight running chains with thermoplastic Top Plates

863 Series

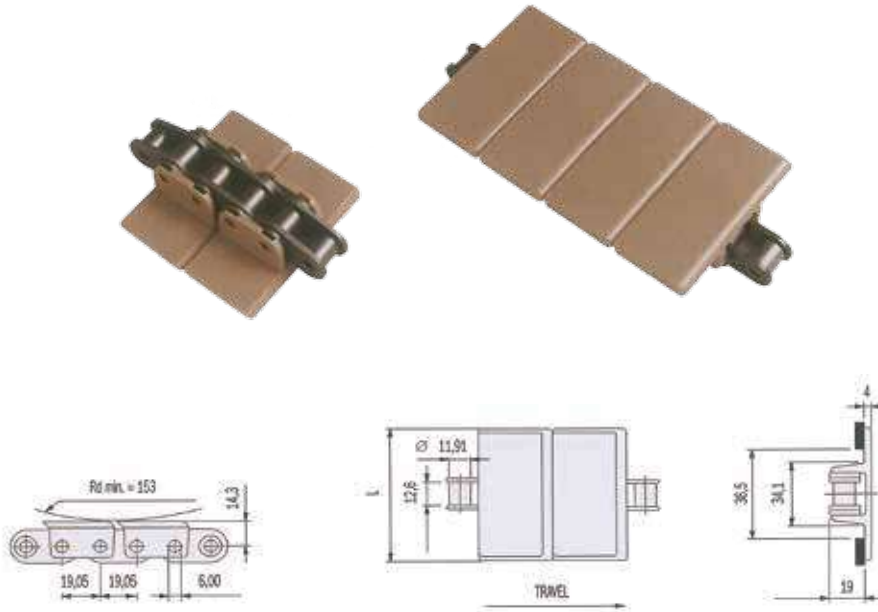

### Designation example

LFA — Mat + Colour  
863 — Chain type  
K 175 — Chain Width

Chain Ref.	Material		Width L mm.	Weight Kg./m.
	Base chain	Top plate		
863 - K 175*	Steel	See page 2	44,5	1,9
863 - K 250			63,5	2,0
863 - K 325			82,5	2,1
863 - K 450			114,3	2,3
863 - K 600*			152,4	2,5
863 - K 750			190,5	2,7

Chain Ref.	Material		Width L mm.	Weight Kg./m.
	Base chain	Top plate		
863 SS - K 175*	Stainless Steel	See page 3	44,5	1,9
863 SS - K 250			63,5	2,0
863 SS - K 325			82,5	2,1
863 SS - K 450			114,3	2,3
863 SS - K 600*			152,4	2,5
863 SS - K 750			190,5	2,7

\*Size produced only upon request.

– Standard shipping lengths = 240 pitches = 10 feet = 3,048 metres.



**“1843” Sideflexing chains with thermoplastic Top Plates**

**1843 Series**

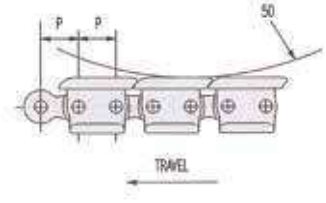
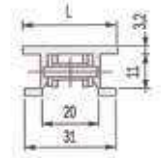
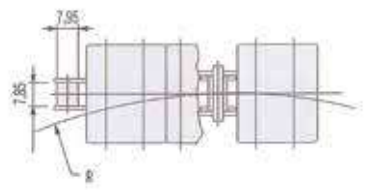

Chain Ref.	Material		Width L mm	Pitch P mm	Min. Radius R mm	Weight Kg/m
	Base chain	Top plate				
1843 TAB - K 125	Steel		31,80			0,74
1843 TAB - K 200	Steel		50,80			0,89
1843 TAB SS - K 125	Stainless Steel	See page 2	31,80	12,7	254	0,74
1843 TAB SS - K 200	Stainless Steel		50,80			0,89

**“1873” Sideflexing chains with thermoplastic Top Plates**

**1873 Series**

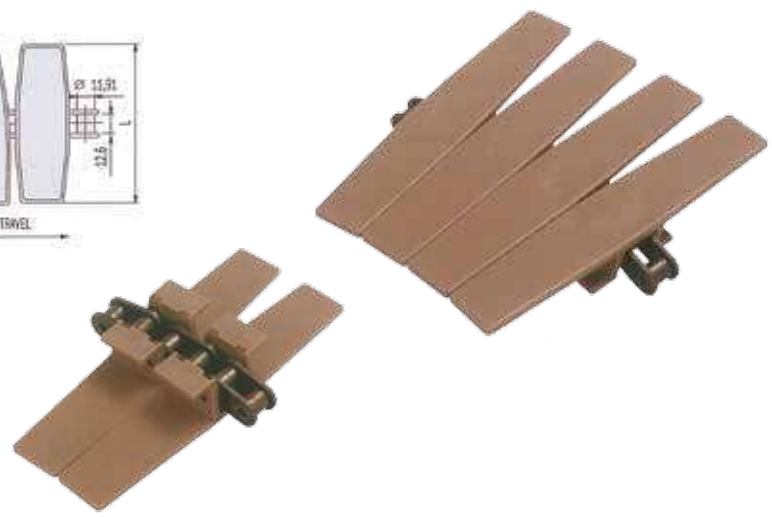
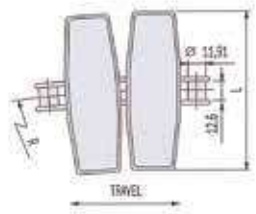
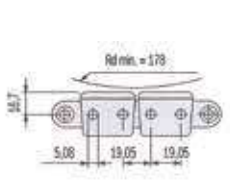

Chain Ref.	Material		Width L mm	Min. Radius R mm	GC Straight mm	GC Curve mm	Weight Kg/m
	Base chain	Top plate					
1873 TAB - K 325 / 1873 TAB SS - K 325	Steel / Stainless Steel		82,5	356			2,1
1873 TAB - K 450 / 1873 TAB SS - K 450	Steel / Stainless Steel		114,3	356			2,3
1873 TAB - K 600 / 1873 TAB SS - K 600	Steel / Stainless Steel	See page 2	152,4	457	33,3	34,6	2,4
1873 TAB - K 750 / 1873 TAB SS - K 750	Steel / Stainless Steel		190,5	457			2,6
1873 TAB - K 1000 / 1873 TAB SS - K 1000	Steel / Stainless Steel		254,0	457			2,8
1873 TAB - K 1200 / 1873 TAB SS - K 1200	Steel / Stainless Steel		304,8	610			3,0

“1843” Sideflexing chains with thermoplastic Top Plate

– Standard shipping lengths = 80 pitches = 10 feet = 3,048 metres.

# Thermoplastic straight running chains with rubber inserts – Single / Double hinge

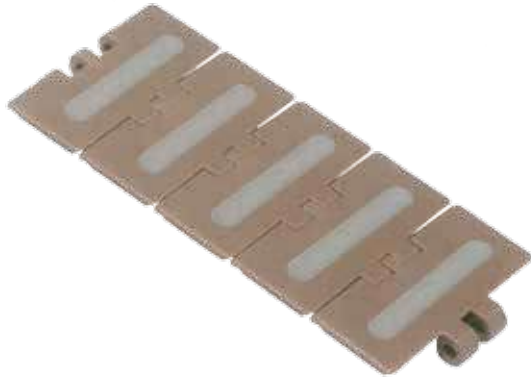

HFL 820  
Series



### High Friction Link

- Plates in self/lubricating acetal resin, light brown-coloured, with rubber inserts.
- Pins in special chrome-nickel stainless steel, work hardened for high resistance.

Chain Ref.	Material		L mm.	Width mm.	B mm.	Weight Kg/m
	Link	Antislip insert				
HFL 820 - K 325*	See page 2	Rubber	82,5		65,0	0,83
HFL 820 - K 350*			88,9		88,9	0,87
HFL 820 - K 400*			101,6		101,6	0,95
HFL 820 - K 450*			114,3	60 Shore A (Grey)	114,3	1,03
HFL 820 - K 600*			152,4		135,0	1,25



HFL 821  
Series

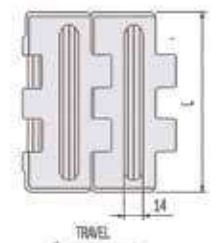
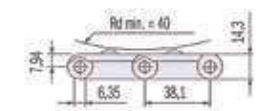

### High Friction Link

- Plates in self/lubricating acetal resin, light brown-coloured, with rubber inserts.
- Pins in special chrome-nickel stainless steel, work hardened for high resistance.

Chain Ref.	Material		L mm.	Width mm.	B mm.	Weight Kg/m
	Link	Antislip insert				
HFL 821 - K 750*	See page 2	Rubber	190,5		132,0	2,50
HFL 821 - K 1000*		60 Shore A	254,0		195,0	2,95
HFL 821 - K 1200*		(Grey)	304,8		245,0	3,25

\*Size produced only upon request.

– Standard shipping lengths = 80 pitches = 10 feet = 3,048 metres.

– Special configurations of distance between inserts are available upon request.

– These chains can be supplied with pins in austenitic stainless steel, work hardened, highly wear resistant, or with pins in thermoplastic resin.

**HFL 880  
TAB Series**

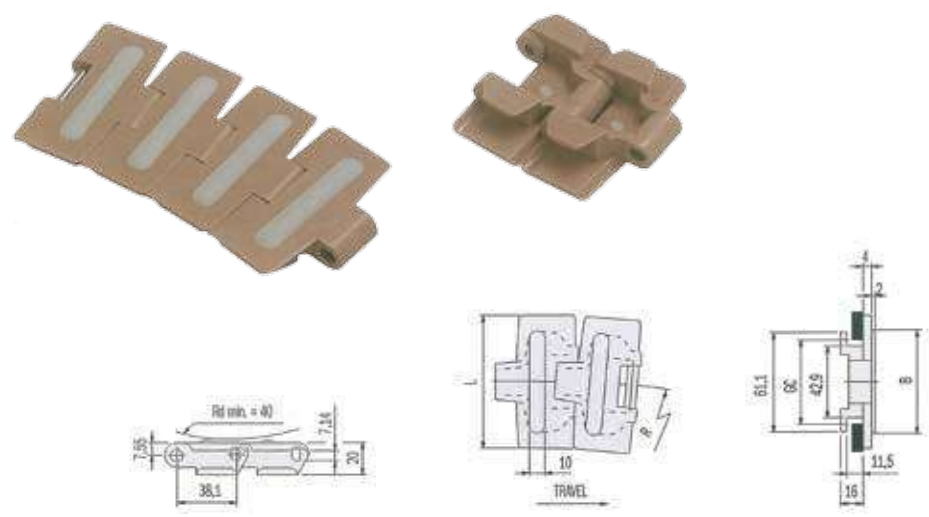

Chain Ref.	Material		L mm.	Width mm.	B mm.	Min. Radius R mm	GC Straight mm	GC Curve mm	Weight Kg/m
	Link	Antislip insert							
HFL 880 TAB - K 325*		Rubber 60 Shore A	82,5		65	400	46	44,2	0,94
HFL 880 TAB - K 450*	See page 2	(Grey)	114,3		95	400	46	44,2	1,08

**HFL 880  
BO Series**

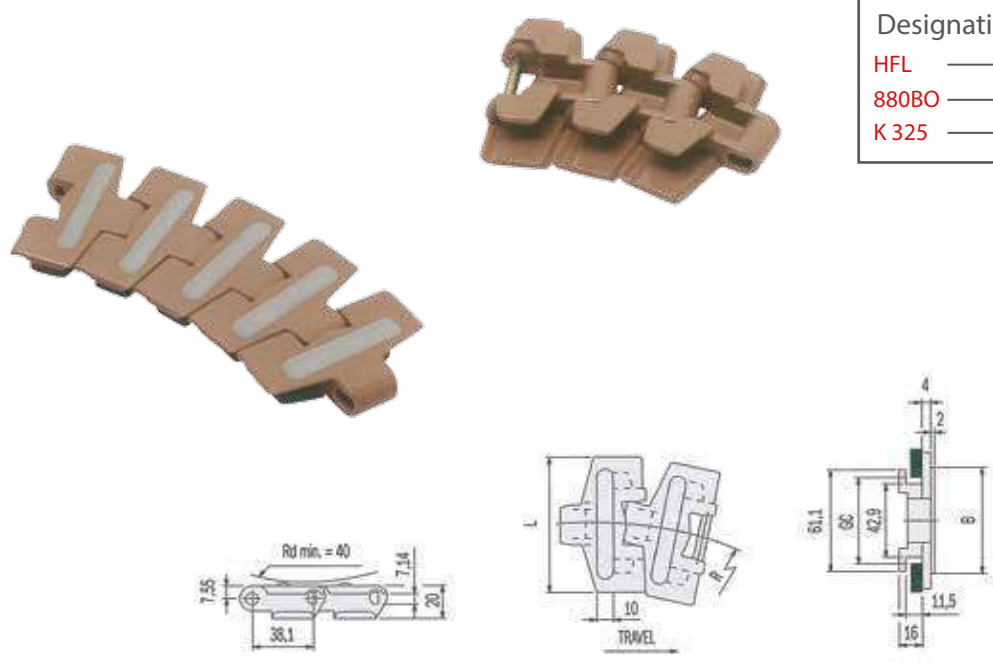

Designation example  
**HFL** — Mat + Colour  
**880BO** — Chain type  
**K 325** — Chain Width

Chain Ref.	Material		L mm.	Width mm.	B mm.	Min. Radius R mm	GC Straight mm	GC Curve mm	Weight Kg/m
	Link	Antislip insert							
HFL 880 BO - K 325*	See page 2	Rubber 60 Shore A (Grey)	82,5		65	190	46	44,2	0,96

\*Size produced only upon request.  
 - Standard shipping lengths = 80 pitches = 10 feet = 3,048 metres.  
 - Special configurations of distance between inserts are available upon request.  
 - These chains can be supplied with pins in austenitic stainless steel, work hardened, highly wear resistant, or with pins in thermoplastic resin.

Thermoplastic sideflexing chains with rubber inserts



HFL 878  
BO Series

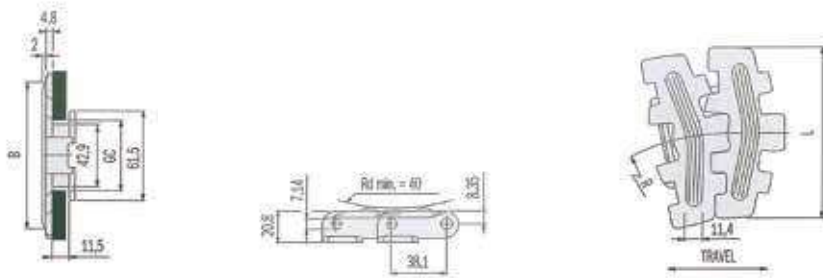

Chain Ref.	Material		L mm.	Width mm.	B mm.	Min. Radius R mm	GC Straight mm	GC Curve mm	Weight Kg/m
	Link	Antislip insert							
HFL 878 BO - K 325 *		Rubber 60 Shore A	82,5		71	190	46	44,2	1,08
HFL 878 BO - K 450*	See page 2	(Grey)	114,3		102	190	46	44,2	1,20

### Designation example

HFL — Mat + Colour  
882 TAB — Chain type  
K 750 — Chain Width



HFL 882  
TAB Series

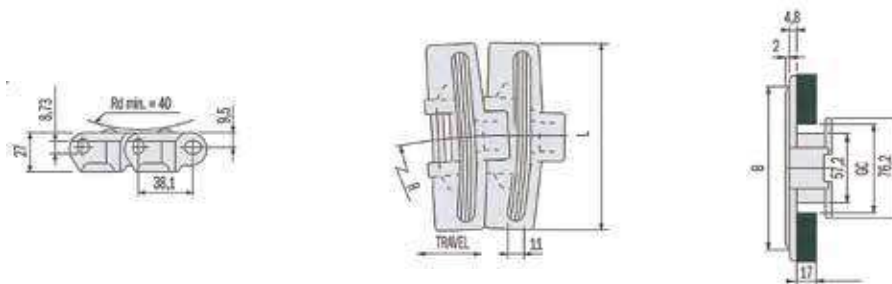

Chain Ref.	Material		L mm.	Width mm.	B mm.	Min. Radius R mm	GC Straight mm	GC Curve mm	Weight Kg/m
	Link	Antislip insert							
HFL 882 TAB - K 750*			190,5		132				2,43
HFL 882 TAB - K 1000*	See page 2	Rubber 60 Shore A	254,0		195	610	60	58	2,87
HFL 882 TAB - K 1200*		(Grey)	304,8		246				3,41

\*Size produced only upon request.

– Standard shipping lengths = 80 pitches = 10 feet = 3,048 metres.

– Special configurations of distance between inserts are available upon request.

– These chains can be supplied with pins in austenitic stainless steel, work hardened, highly wear resistant, or with pins in thermoplastic resin.

HFL 1873  
TAB Series

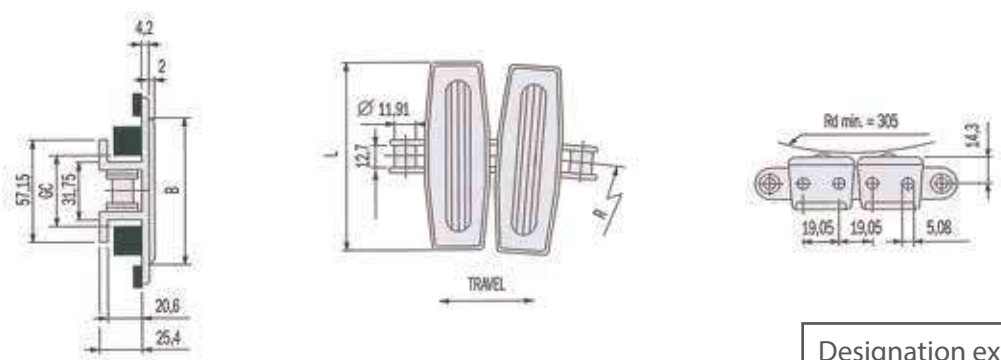
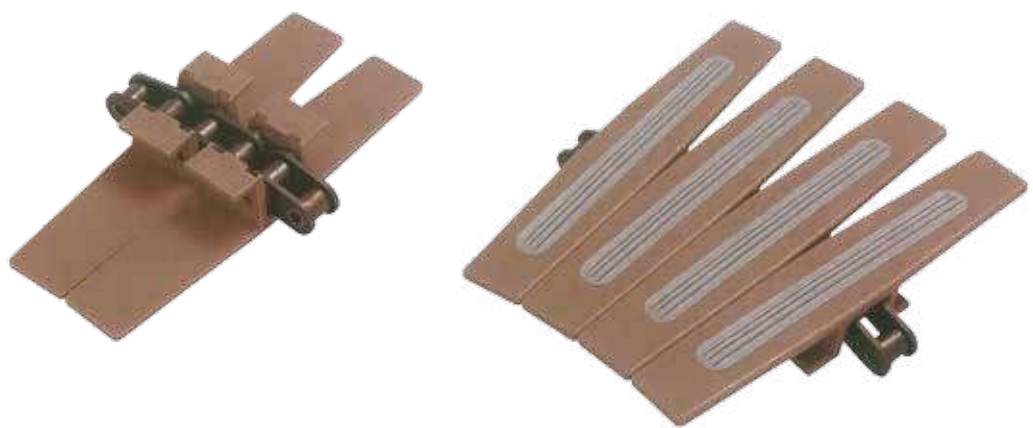

Designation example  
HFL — Mat + Colour  
1873 TAB — Chain type  
K 325 — Chain Width

Chain Ref.	Material		L mm.	Width mm.	B mm.	Min. Radius R mm	GC Straight mm	GC Curve mm	Weight Kg/m
	Base chain	Top Plate							
HFL 1873 TAB - K 325	Steel	See page 2	82,5	82,5	457	33,3	34,6	2,60	
HFL 1873 TAB - K 350			88,9	88,9	457				2,65
HFL 1873 TAB - K 375			95,2	95,2	457				2,70
HFL 1873 TAB - K 450			114,3	114,3	457				2,80
HFL 1873 TAB - K 600			152,4	132	457				2,90
HFL 1873 TAB - K 750			190,5	132	457				3,10
HFL 1873 TAB - K 1000			254,0	195	457				3,40
HFL 1873 TAB - K 1200			304,8	245	610				3,60

HFL 1873 TAB SS - K 325	Stainless	See page 2	82,5	82,5	457	33,3	34,6	2,60	
HFL 1873 TAB SS - K 350			88,9	88,9	457				2,65
HFL 1873 TAB SS - K 375			95,2	95,2	457				2,70
HFL 1873 TAB SS - K 450			114,3	114,3	457				2,80
HFL 1873 TAB SS - K 600			152,4	132	457				2,90
HFL 1873 TAB SS - K 750			190,5	132	457				3,10
HFL 1873 TAB SS - K 1000			254,0	195	457				3,40
HFL 1873 TAB SS - K 1200			304,8	245	610				3,60

\*Size produced only upon request.  
– Standard shipping lengths = 80 pitches = 10 feet = 3,048 metres.  
– Special configurations of distance between inserts are available upon request.

“1873” Sideflexing chains with themoplastic Top Plates and rubber inserts



# Double hinge straight running chains - with low noise accumulation rollers

**Applications:**

- Food and beverage industry packaging line (for ex. PET bottles in heat shrink film).
- General purpose conveying applications to reduce pressure created between product and flight surface.

**Advantages:**

- High ultimate load.
- Rollers manufactured in low friction and low noise material: reduced back-line pressure and low noise level.
- Heavy duty.

**Characteristics:**

This new series of thermoplastic chains is the solution to the pressure created between products and the conveying surface created by the accumulation of product. This is achieved by having a series of small width rollers which provides a stable conveying surface and enables the product to be handled without damage, however the chain still provides a positive forward motion and is based on our standard series LF821 / LF8257 / LF831 / LF882 chain.

**Designation example**

- LBP — Mat + Colour
- 821 — Chain type
- K 750 — Chain Width

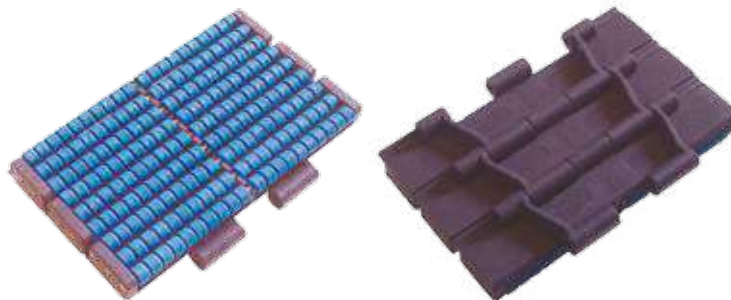

**LBP 821  
Series**

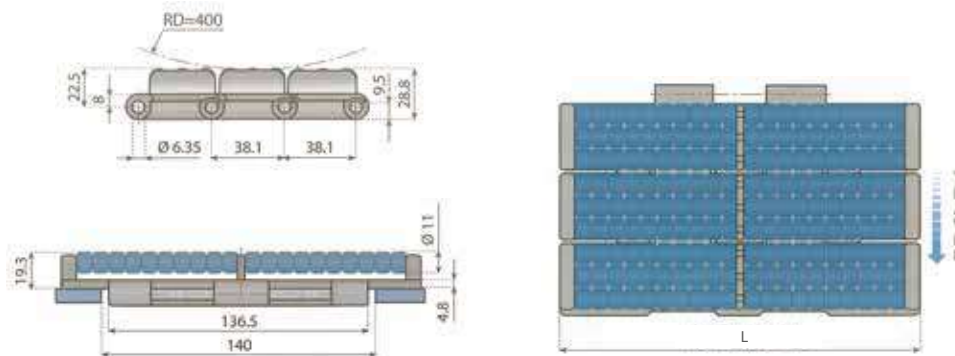

Chain Ref.	Material		Breaking Load N	Width L		Weight Kg/m
	Plate	Roller		mm.	inch.	
LBP 821 - K750				190,5	7.1/2	5.52
LBP 821 - K1000	Dark Grey	Light Grey	8300	254.0	10	6.90
LBP 821 - K1200				304.8	12	8.00

– Standard length: 40 pitches (5 Ft. - 1.524 m.)

**Straight running chains - Heavy duty single hinge  
- with low noise accumulation rollers**

**LBP 8257 Series**

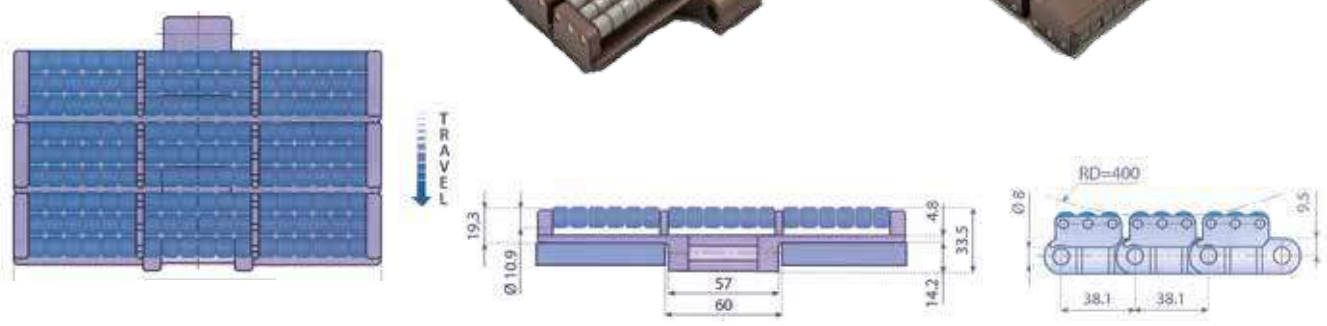

Chain Ref.	Material		Breaking Load N	Width L		Weight Kg/m
	Plate	Roller		mm.	inch.	
LBP 8257 - K750				190,5	7.1/2	5.65
LBP 8257 - K1000	Dark Grey	Light Grey	10000	254.0	10	7.20
LBP 8257 - K1200				304.8	12	8.10

**Designation example**  
**LBP** — Mat + Colour  
**8257** — Chain type  
**K 750** — Chain Width

**Single hinge straight running chains  
- with low noise accumulation rollers**

**LBP 831 Series**



**Designation example**  
**LBP** — Mat + Colour  
**831** — Chain type  
**K 325** — Chain Width

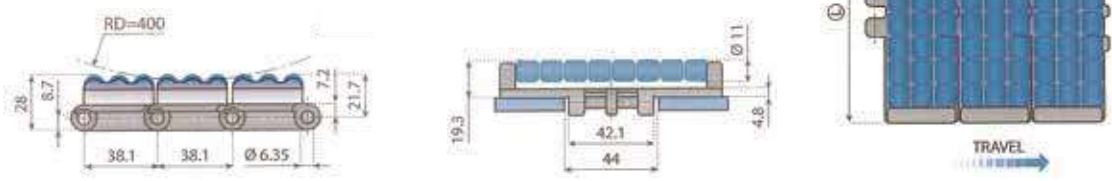

Chain Ref.	Material		Breaking Load N	Width L		Weight Kg/m
	Plate	Roller		mm.	inch.	
LBP 831 - K325				82,5	3.1/4	2.15
LBP 831 - K450	Dark Grey	Light Grey	5000	114.3	4.1/2	2.85

— Standard length: 40 pitches (5 Ft. - 1.524 m.).

Straight running chains - Heavy duty single hinge

# Sideflexing chains - with low noise accumulation rollers

LBP 882  
TAB Series

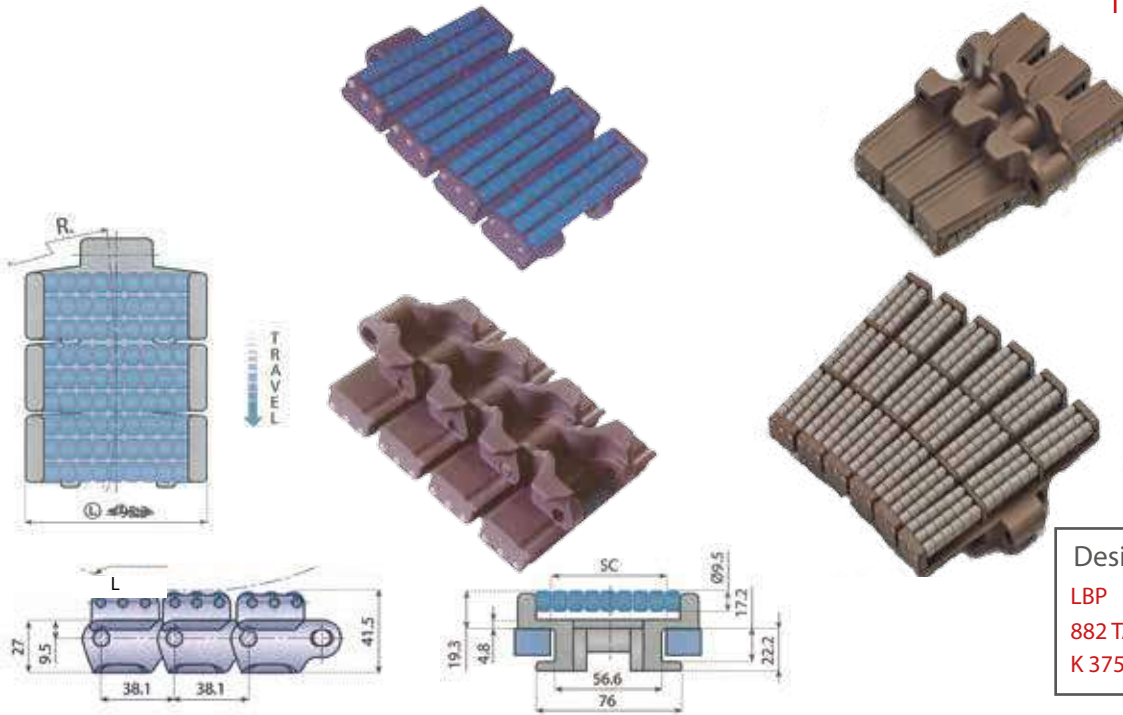

Designation example

LBP — Mat + Colour  
882 TAB — Chain type  
K 375 — Chain Width

Chain Ref.	Material		Breaking Load N	Width L		R. min.	SC		Weight Kg/m
	Plate	Roller		mm.	inch.		Straight	Curving	
LBP 882 TAB - K375	LF Dark Grey	Light Grey	10000	95.3	3.3/4	610	60	58	3.31
LBP 882 TAB - K450				114.3	4.1/2				
LBP 882 TAB - K750				190.5	7.1/2				
LBP 882 TAB - K1000				254	10				
LBP 882 TAB - K1200				304.8	12				

- Standard length: 40 pitches (5 Ft. - 1.524 m.)



8211  
Series

# Flex thermoplastic chains

1700  
Series

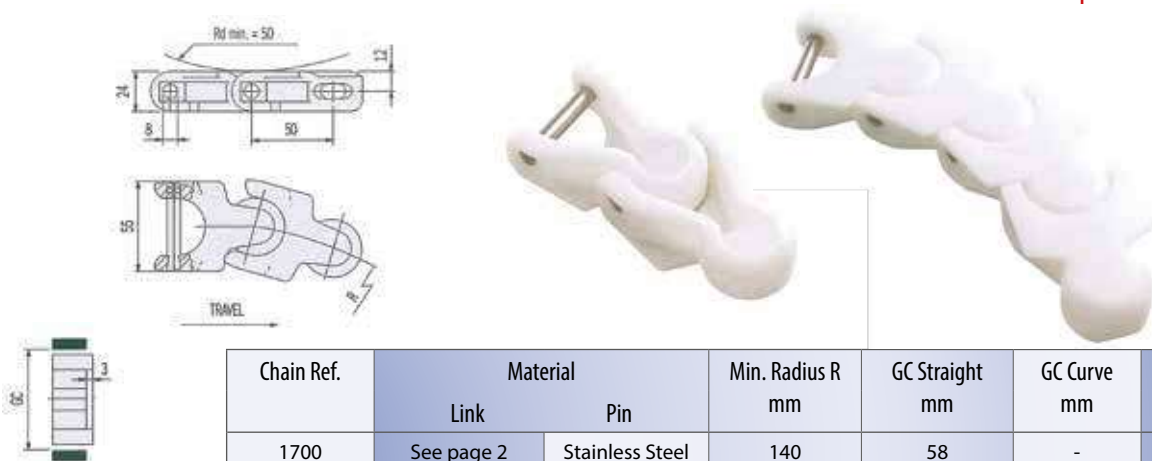

Chain Ref.	Material		Min. Radius R mm	GC Straight mm	GC Curve mm	Weight Kg/m
	Link	Pin				
1700	See page 2	Stainless Steel	140	58	-	1,26

Single hinge straight running chains  
- with low noise accumulation rollers

**1701 TAB Series**

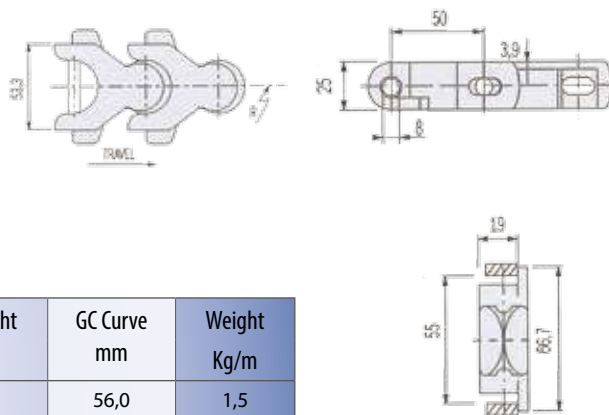

Chain Ref.	Material		Min. Radius R mm	GC Straight mm	GC Curve mm	Weight Kg/m
	Link	Pin				
1701 TAB	See page 2	Stainless Steel	150	57,5	56,0	1,5

- One box = 6,1 metres.

**1702 Series**

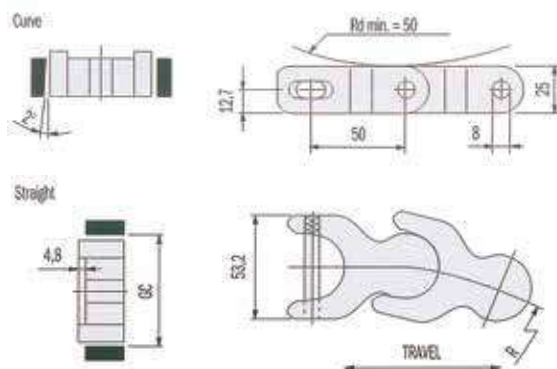

Chain Ref.	Material		Min. Radius R mm	GC Straight mm	GC Curve mm	Weight Kg/m
	Link	Pin				
1702	See page 2	Stainless Steel	140	59,5	56,8	1,43

Designation example  
**LFW** — Mat + Colour  
**1702** — Chain type

- One box = 6,1 metres.

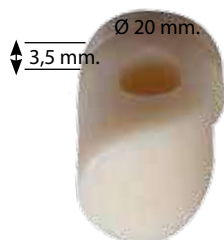
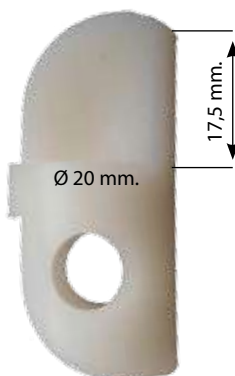
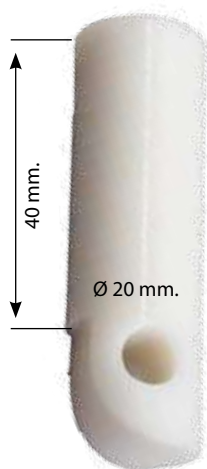

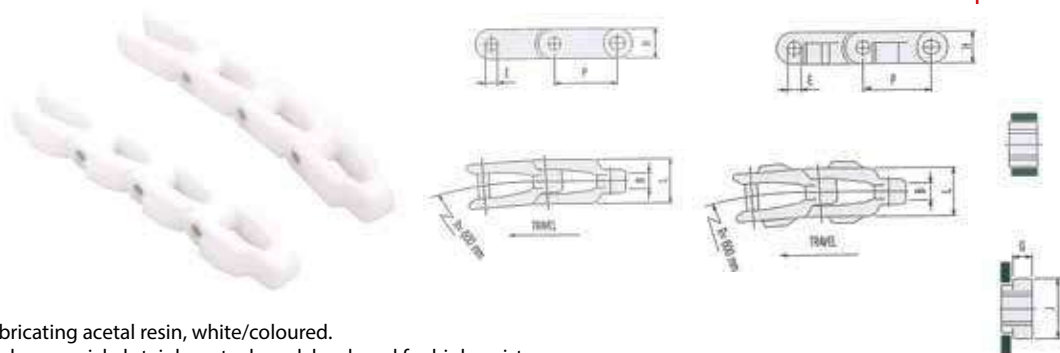

**CC 600-O Series**

**Acetal Resin**

- Links in self/lubricating acetal resin, white/coloured.
- Pins in special chrome-nickel stainless steel, work hardened for high resistance.

Chain Ref.	Material	Pitch P	Width L mm.	Pin Diameter E mm.	Max Sprocket Face B mm.	Depth of sidebar H mm.	Width Over Lug J mm.	Height Over Lug G mm.	Weight Kg./m.
CC 600	Acetal	63,5	43	11	14,3	29	-	-	1,44
CC 600 TAB	Acetal	63,5	43	11	14,3	29	54	15	1,49

- Standard shipping lengths = 96 pitches = 20 feet = 6,1 metres.
- Special configurations of distance between inserts are available upon request.

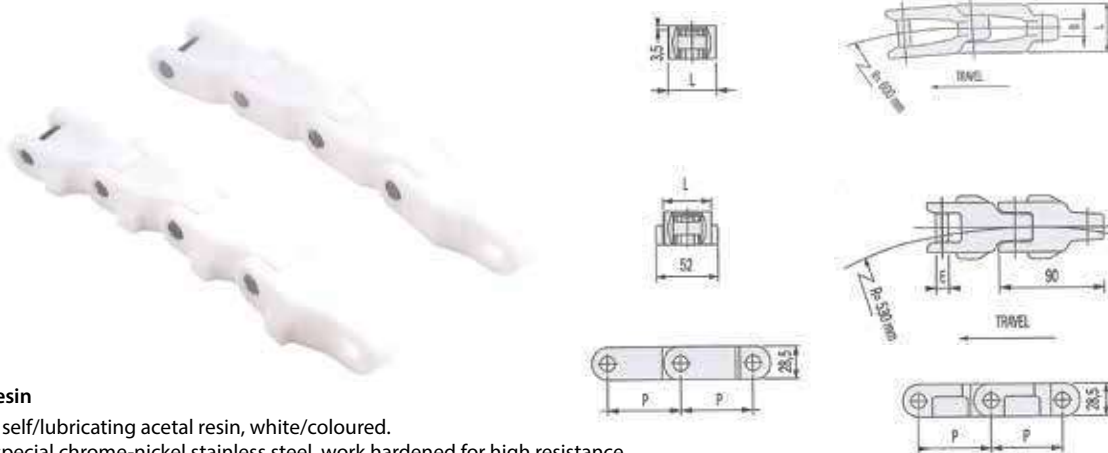

**CC 600 C Series**

**Acetal Resin**

- Links in self/lubricating acetal resin, white/coloured.
- Pins in special chrome-nickel stainless steel, work hardened for high resistance.

Chain Ref.	Material	Pitch P	Width L mm.	Pin Diameter E mm.	Max Sprocket Face B mm.	Depth of sidebar H mm.	Width Over Lug J mm.	Height Over Lug G mm.	Weight Kg./m.
CC 600 C	Acetal	63,5	43	11	14,3	29	-	-	1,42
CC 600 C TAB	Acetal	63,5	43	11	14,3	29	52	15	1,55

- Standard shipping lengths = 96 pitches = 20 feet = 6,1 metres.

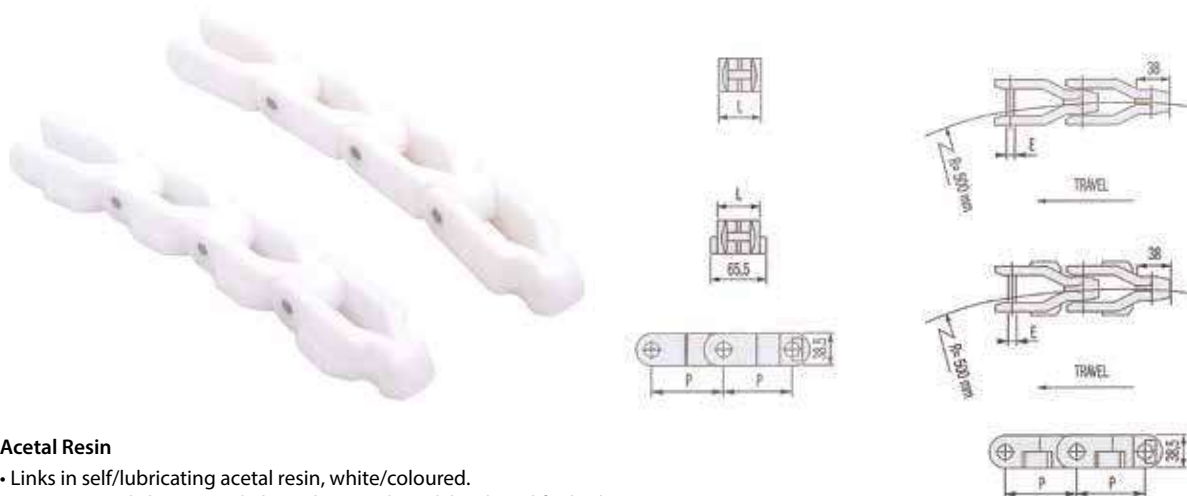

**CC 1400 Series**

**Acetal Resin**

- Links in self/lubricating acetal resin, white/coloured.
- Pins in special chrome-nickel stainless steel, work hardened for high resistance.

Chain Ref.	Material	Pitch P	Width L mm.	Pin Diameter E mm.	Max Sprocket Face B mm.	Depth of sidebar H mm.	Width Over Lug J mm.	Height Over Lug G mm.	Weight Kg./m.
CC 1400	Acetal	82,5	50	9,5	15,9	38	-	-	1,44
CC 1400 TAB	Acetal	82,5	50	9,5	15,9	38	66	19	2,26

- Standard shipping lengths = 74 pitches = 20 feet = 6,105 metres.

## CHAINS

Standard chain types	H mm	W mm	W2 mm	P mm	R mm	Max Load kN	Kg mtr
2000 A	32,5	41		50,8	500	6	1,7
2000 AS	32,5	41		50,8	500	5,5	1,7
2000 PG-LG	32,5	41		50,8	500	3,5	1,4
2000 PG-R	32,5	41		50,8	500	3,5	1,4
2000 PG-S	32,5	41		50,8	500	3,5	1,4
2000 PG-LG-SF	32,5	41		50,8	500	3,5	1,4
2000 PG-S-SF	32,5	41		50,8	500	3,5	1,4
2000 RF <sup>1</sup>	30	40		50,8	500	40	5,2
2500 A	40	46		63,5	550	8,5	2,2
2500 A-RTS	40	46		63,5	550	8,5	2,2
2500 A-SK	40	46	74,5	63,5	550	8,5	2,35
2500 A-SK-KR	40	46	74,5	63,5	550	8,5	2,35
2500 AS	40	46		63,5	550	8	2,2
2500 AS-SK	40	46	74,5	63,5	550	8	2,35
2500 AS-SK-KR	40	46	74,5	63,5	550	8	2,35
2500 PG-LG	40	46		63,5	550	4,5	1,9
2500 PG-S	40	46		63,5	550	4,5	1,9
2500 NG	40	46		63,5	550	7,5	2,2
2500 NG-SK	40	46	74,5	63,5	550	8,5	2,35
2500 NG-SK-KR	40	46	74,5	63,5	550	8,5	2,35
3000 A	47	54		76,2	600	11	3
3000 AS	47	54		76,2	600	10,5	3
3000 AS-SK	47	54	66	76,2	600	6	2,5
3000 PG-LG	47	54		76,2	600	6	2,5
3000 PG-S <sup>2</sup>	47	54		76,2	600	6	2,5
3000 PG-S-SF	47	54		76,2	600	10,5	2,5

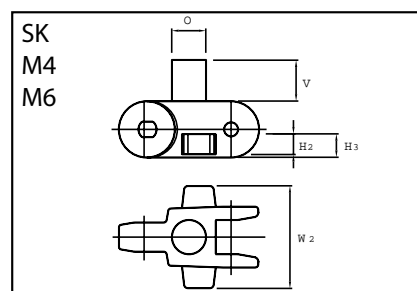
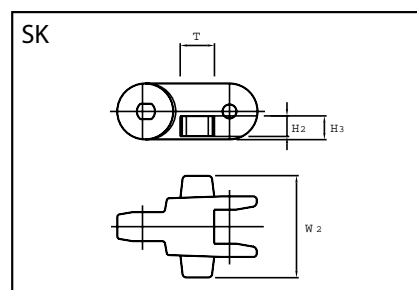
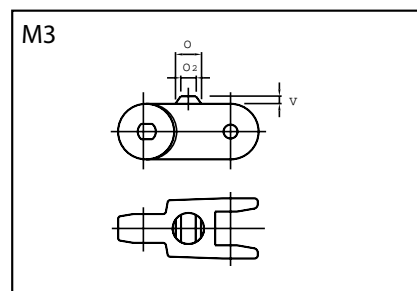
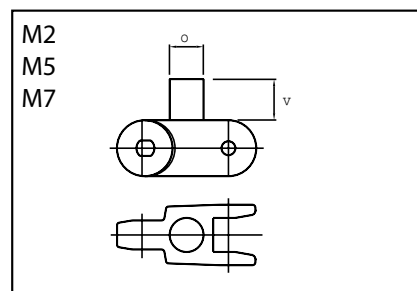
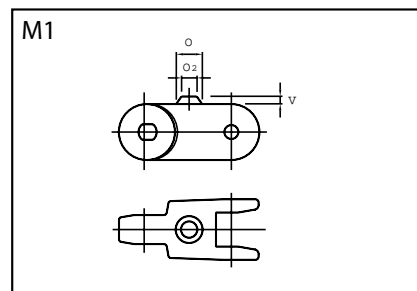
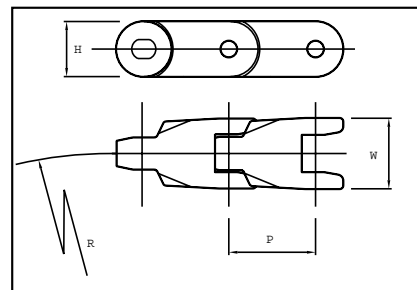

Pushers and tab options	O mm	O2 mm	V mm	H2 mm	H3 mm	W2 mm	T mm
2000 M1	Ø17	10	5				
M2	Ø17		16				
2500 M3	Ø17	10	5				
M4	Ø21		15				
M5	Ø21		19				
M6	Ø21		25				
3000 M7	Ø27		20				
2500 SK			15	17	74,5	25	
3000 SK			19		66	30	



# CHAINS



The chains from ScanBelt Nordic were developed specifically for crate conveyors and washers. The first chains were produced more than 50 years ago. The choice of materials is a result of the close collaboration with Europe's leading machine manufacturers in the food industry. In addition, ScanBelt Nordic has also been collaborating with a large number of producers of beverages and dairy products while developing the chain programme.

Legend  
 0 = Little resistance, not recommended  
 • = Average resistance  
 •• = Good resistance, it can be used

CHEMICAL AGENT	Acetal Resin D	Acetal Resin LFA/WLF	Acetal Resin SP	Special Acetal Resin WR	Antistatic Resin AS	Polypropylene PPB
Acetic acid	0	0	0	••	0	••
Acetone	•	•	•	••	•	••
Aluminium chloride	0	0	0	••	0	0
Ammonia	••	••	••	••	••	••
Ammonium chloride	0	0	0	••	0	0
Amyl alcohol	0	0	0	••	0	••
Aniline	••	••	••	•	••	••
Beer	••	••	••	••	••	••
Benzene	••	••	••	••	••	••
Benzoic acid	0	0	0	•	0	••
Benzol	••	••	••	••	••	•
Boric acid	••	••	••	••	••	••
Brine	•	•	•	•	•	••
Butter	••	••	••	••	••	••
Butyl alcohol	0	0	0	••	0	••
Butyric acid	0	0	0	0	0	••
Calcium chloride	•	•	•	••	•	••
Carbon disulphide	••	••	••	••	••	••
Carbon tetrachloride	••	••	••	••	••	0
Caustic soda (20 %)	0	0	0	••	0	••
Cheese	••	••	••	0	••	••
Chlorine water	0	0	0	••	0	0
Chloroform	0	0	0	0	0	•
Citric acid	•	•	•	•	•	••
Copper sulphate	••	••	••	••	••	••
Diet oil	••	••	••	••	••	••
Diet fat	••	••	••	••	••	••
Distilled water	••	••	••	••	••	••
Ethyl acetate	0	0	0	••	0	••
Ethyl alcohol	••	••	••	••	••	••
Ethyl chloride	••	••	••	••	••	0
Ethyl ether	••	••	••	••	••	••
Flax oil	0	0	0	••	0	••
Formaldehyde	••	••	••	••	••	••
Formic acid	0	0	0	0	0	••
Freon 12	0	0	0	••	0	0
Fresh water	••	••	••	••	••	••
Fruit juice	••	••	••	••	••	••
Gasoline	••	••	••	••	••	•
Glycerin	••	••	••	••	••	••
Hydrochloric acid	0	0	0	0	0	••
Hydrofluoric acid	0	0	0	0	0	••
Hydrogen peroxide	0	0	0	0	0	••
Iodine	••	••	••	0	••	••
Iron chloride	0	0	0	••	0	••
Lactic acid	••	••	••	••	••	••
Magnesium chloride	0	0	0	••	0	••
Mercury	••	••	••	••	••	••
Methyl alcohol	••	••	••	••	••	••
Methylene chloride	0	0	0	••	0	•
Milk	••	••	••	••	••	••
Nitric acid	0	0	0	0	0	••
Oil	••	••	••	••	••	•
Oil ether	••	••	••	••	••	••
Oleic acid	0	0	0	••	0	••
Paraffin	••	••	••	0	••	•
Phenol	0	0	0	0	0	••
Phosphoric acid	0	0	0	••	0	••
Potassium hydroxide	0	0	0	••	0	0
Sea water	•	•	•	••	•	••
Silicon oil	0	0	0	••	0	••
Silver nitrate	0	0	0	••	0	••
Soapy water	••	••	••	••	••	••
Sodium carbonate	••	••	••	••	••	••
Sodium chloride	••	••	••	••	••	••
Sodium hydroxide	••	••	••	••	••	••
Sodium hypochlorite	0	0	0	••	0	••
Sodium silicate	0	0	0	••	0	0
Sodium sulphate	••	••	••	••	••	••
Soft drinks	••	••	••	••	••	••
Suds	0	0	0	••	0	••
Sulphuric acid	0	0	0	0	0	••
Tartaric acid	•	•	•	••	•	••
Tetraline	0	0	0	••	0	0
Tincture of iodine	••	••	••	0	••	••
Transformer oil	0	0	0	••	0	•
Trichloroethylene	0	0	0	•	0	•
Turpentine	0	0	0	•	0	0
Vegetable juice	••	••	••	••	••	••
Vegetable oil	••	••	••	••	••	••
Vinegar	••	••	••	••	••	••
Whisky	••	••	••	••	••	••
Wine	••	••	••	••	••	••
Xilol	••	••	••	••	••	0
Zinc chloride	0	0	0	•	0	••

Plastic corrosion resistance table



Among our broad product range you will also find a vast selection of high-quality metal conveyor chains available in carbon steel, stainless steel and naturally in different sizes. Due to the many different surfaces and grades of hardness in which these chains can be supplied, the varieties of applications are endless. This enables us to offer high-speed, high wear or low noise chains etc. for curves, magnetic curves, straight running or even inclined/declined conveyors.

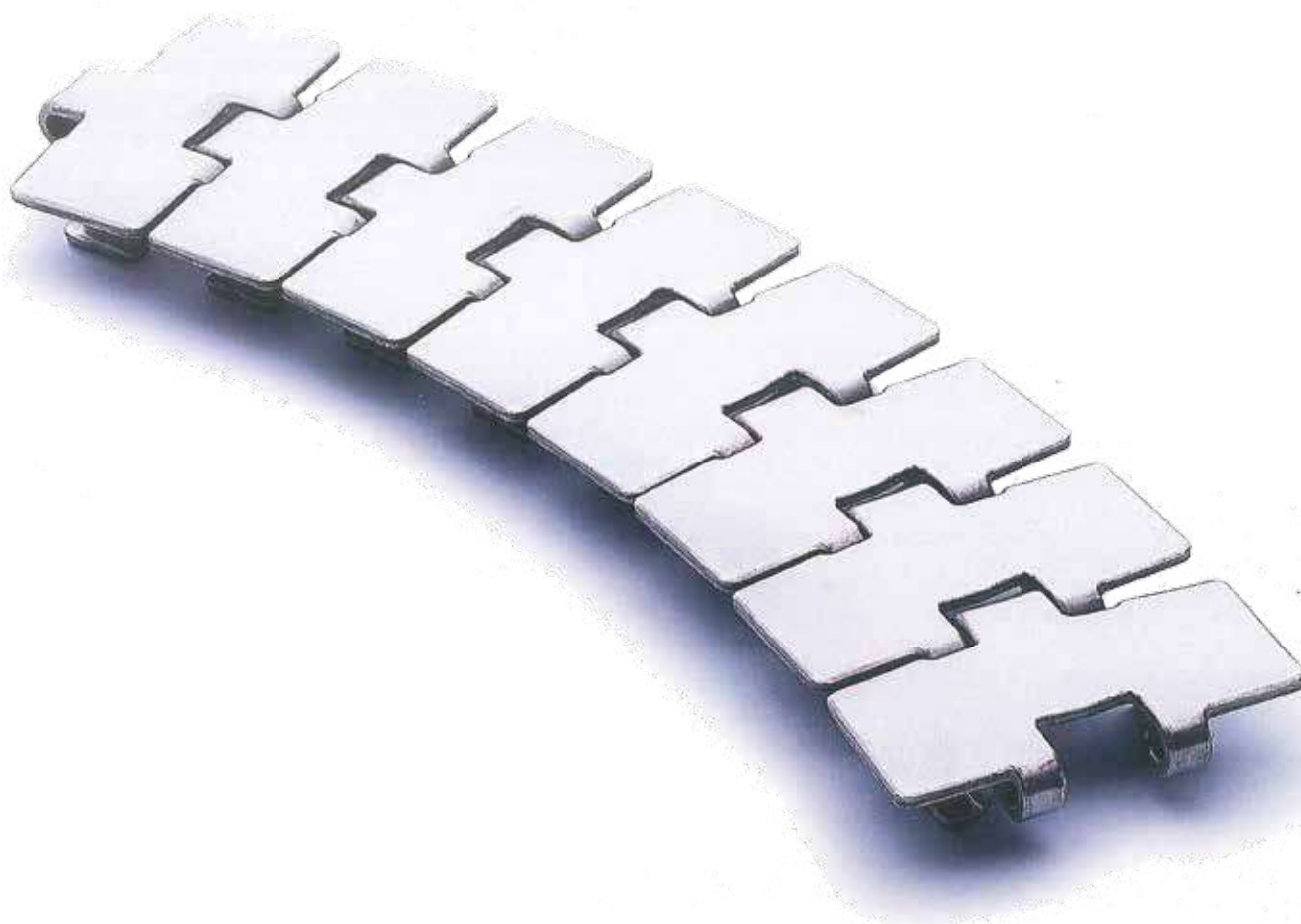

The chains are produced with high quality steel / stainless steel in order to satisfy the growing needs of technological progress on the conveying lines.

**SLATS**

**Hard Inox**

Special work hardened chrome-nickel, highly wear corrosion resistant stainless steel. It offers excellent mechanical characteristics and exceptional sliding properties, thanks to a very low surface roughness.

It is particularly suitable for the critical points of bottling lines.

Material used for the following chain models: Super, Flex RXMS, Flex FMS, Flex FMS2, New Flex Mag, Super-G, Flex RXMS-G and New Flex Mag-G.

**Inox**

Ferritic, AISI 430 stainless steel, work hardened by cold-rolling, with good corrosion resistance. It has an excellent surface finishing with a low roughness, that is very important quality for the sliding of conveyed products. It is the preferred choice for standard bottling industry applications.

Material used for the following chain models: Special, Standard and Flex RXMC.

**HQ Inox (High Quality)**

Special, new, chrome-nickel (W.1.4589) stainless steel, work hardened. It has been developed in cooperation with a major stainless steel manufacturer for very special applications such as pressureless combiners/inliners. Cold rolled to extremely high quality standards, this material is the right answer to the most sophisticated needs. Its exceptional surface finishing and flatness together with a very high working load and wear resistance are unique features.

Material used for the following chain models: Superspeed, Wear-Proof, Flex FMD and New Flex Mag-D.

**Inox 18/8**

Austenitic, non-magnetic AISI 304 stainless steel (18% Chrome - 8% Nickel), work hardened for high resistance. It provides excellent resistance to chemical agents and corrosion, and offers excellent mechanical and duration characteristics. It is mainly used in the preservation and bottling industry. Approved by Food and Drug Administration (FDA), American government institute for the direct contact with foodstuff.

Material used for the following chain models: Stella D, Flex RXM, Flex FM and Flex FM2.

**Inox 316**

Austenitic, non-magnetic AISI 316 stainless steel (18% Chrome - 14% Nickel - 3% Molybdenum). It is ideal with chemical agents and strong acids. Material used for the following chain models: 316 and Flex RXM 316.

**Carbon Steel**

Heat-treated carbon steel with a surface and core hardness of 43 HRC. It is especially suitable for high working loads and it is highly resistant to wear. It is recommended for the glass, ceramic and general product conveying industry. In case of difficult applications, such as with abrasive dust, the carbon steel can be, upon request, case hardened, thus reaching a surface hardness of 55 HRC and a core hardness of 40 HRC.

Material used for the following chain models: Accate and Flex RXMA.

Materials	Minimum temperatures	Maximum temperatures	
		Dry env.	Wet env.
Inox	- 40°C	+ 260°C	+ 120°C
Hard Inox	- 40°C	+ 400°C	+ 120°C
HQ Inox	- 40°C	+ 430°C	+ 120°C
Inox 18/8	- 40°C	+ 400°C	+ 120°C
Inox 316	- 40°C	+ 400°C	+ 120°C
Carbon Steel	- 40°C	+ 180°C	+ 120°C

812  
Series

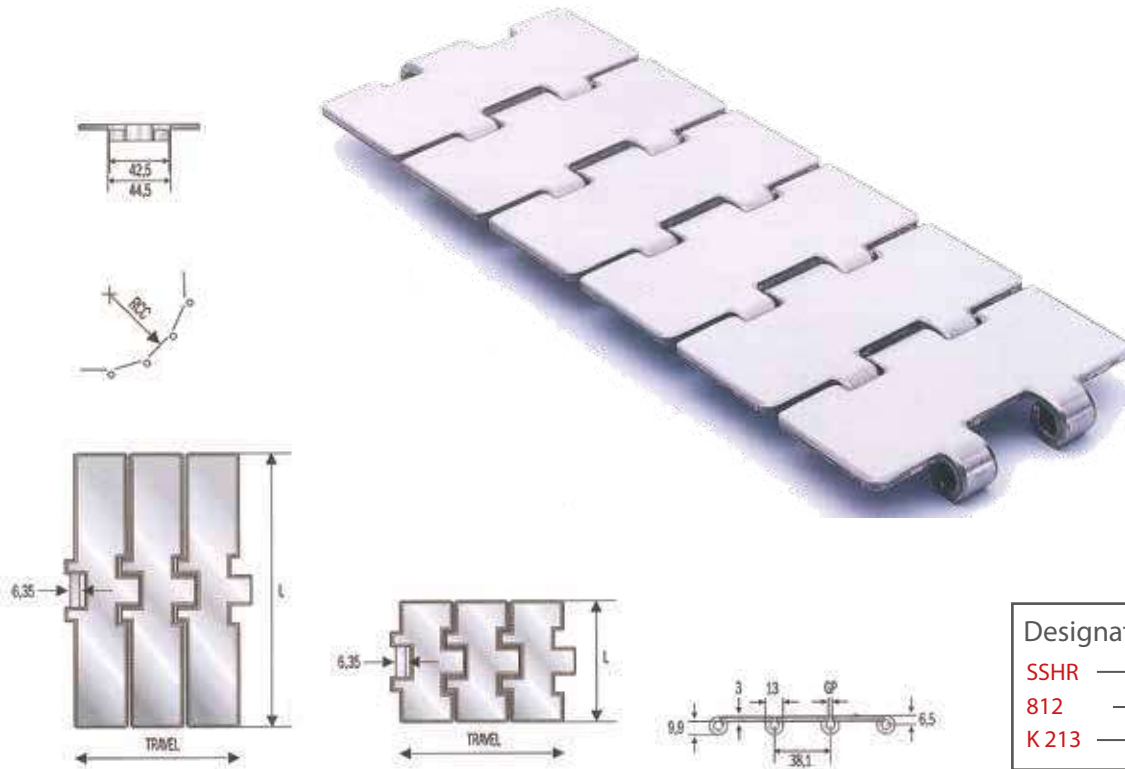

Designation example

SSHR — Material  
812 — Chain type  
K 213 — Chain Width

### SUPER - Hard Inox

- Special, chrome-nickel, stainless steel slats, work hardened for high resistance, with shiny surface having a roughness of  $Ra \leq 0.3$  microns.
- AISI 431 stainless steel pins, magnetic and work hardened for high resistance.

Chain Ref.	Model	L=Slat width		Hardness HRC	GP mm.	RCC mm.	Weight per metre Kg./m.
		mm.	"				
SSHR 812 - K 213	Super	54,1	-	30	2,8	75	2,10
SSHR 812 - K 250	Super	63,5	2 1/2	30	2,8	75	2,20
SSHR 812 - K 263	Super	66,7	2 5/8	30	2,8	75	2,30
SSHR 812 - K 300	Super	76,2	3	30	2,8	75	2,45
SSHR 812 - K 325	Super	82,5	3 1/4	30	2,8	75	2,60
SSHR 812 - K 335	Super	85,0	-	30	2,8	75	2,68
SSHR 812 - K 350	Super	88,9	3 1/2	30	2,8	75	2,70
SSHR 812 - K 500	Super	127,0	5	30	2,8	75	3,50

SSH 812 - K 225	Super	57,1	2 1/4	30	1,6	150	2,18
SSH 812 - K 250	Super	63,5	2 1/2	30	1,6	150	2,25
SSH 812 - K 275	Super	69,9	2 3/4	30	1,6	150	2,35
SSH 812 - K 300	Super	76,2	3	30	1,6	150	2,50
SSH 812 - K 325	Super	82,5	3 1/4	30	1,6	150	2,65
SSH 812 - K 375	Super	95,3	3 3/4	30	1,6	150	2,85
SSH 812 - K 400	Super	101,6	4	30	1,6	150	3,00
SSH 812 - K 450	Super	114,3	4 1/2	30	1,6	150	3,30
SSH 812 - K 600	Super	152,4	6	30	1,6	150	4,20
SSH 812 - K 750	Super	190,5	7 1/2	30	1,6	150	5,10

- Standard shipping lengths = 80 pitches = 10 feet = 3,048 metres.

**812**  
 Series

**SUPER SPEED - HQ Inox**

- Special, new stainless steel, chrome-nickel (W.1.4589) slats, work hardened for high resistance with very little roughness of Ra ≤ 0.18 microns.
- Special stainless steel pins, magnetic and heat treated for high speed systems.

The chain is produced with a special profile: thanks to its perfect levelness and shiny surface, it is particularly suitable for pressureless combiners/inliners and high speed systems.

Chain Ref.	Model	L=Slat width		Hardness	GP	RCC	Weight per metre
		mm.	"	HRC	mm.	mm.	Kg./m.
SSX 812 - K 325	Superspeed	82,5	3 1/4	30	1,6	150	2,60

**WEAR-PROOF - HQ Inox**

- Special, new stainless steel, chrome-nickel (W.1.4589) slats, work hardened for high resistance with very little roughness of Ra ≤ 0.2 microns.
- Special stainless steel pins, magnetic and heat treated for high resistance.

Chain Ref.	Model	L=Slat width		Hardness	GP	RCC	Weight per metre
		mm.	"	HRC	mm.	mm.	Kg./m.
SSHQR 812 - K 325	Wear-Proof	82,5	3 1/4	30	2,8	75	2,60

SSHQ 812 - K 325	Wear-Proof	82,5	3 1/4	30	1,6	150	2,65
------------------	------------	------	-------	----	-----	-----	------

**STANDARD - Inox**

- Ferritic, AISI 430 stainless steel slats, work hardened with shiny surface having low roughness.
- AISI 431 stainless steel pins, magnetic and work hardened for high resistance.

Chain Ref.	Model	L=Slat width		Hardness	GP	RCC	Weight per metre
		mm.	"	HRC	mm.	mm.	Kg./m.
SSR 812 - K 213	Standard	54,1	-	20	2,8	75	2,10
SSR 812 - K 250	Standard	63,5	2 1/2	20	2,8	75	2,20
SSR 812 - K 263	Standard	66,7	2 5/8	20	2,8	75	2,30
SSR 812 - K 300	Standard	76,2	3	20	2,8	75	2,45
SSR 812 - K 335	Standard	85,0	-	20	2,8	75	2,68
SSR 812 - K 350	Standard	88,9	3 1/2	20	2,8	75	2,70

SS 812 - K 225	Standard	57,1	2 1/4	20	1,6	150	2,18
SS 812 - K 250	Standard	63,5	2 1/2	20	1,6	150	2,25
SS 812 - K 275	Standard	69,9	2 3/4	20	1,6	150	2,35
SS 812 - K 300	Standard	76,2	3	20	1,6	150	2,50
SS 812 - K 325	Standard	82,5	3 1/4	20	1,6	150	2,65
SS 812 - K 400	Standard	101,6	4	20	1,6	150	3,00
SS 812 - K 450	Standard	114,3	4 1/2	20	1,6	150	3,30
SS 812 - K 600	Standard	152,4	6	20	1,6	150	4,20
SS 812 - K 750	Standard	190,5	7 1/2	20	1,6	150	5,10

- Standard shipping lengths = 80 pitches = 10 feet = 3,048 metres.

# Straight running chains

## - Single hinge

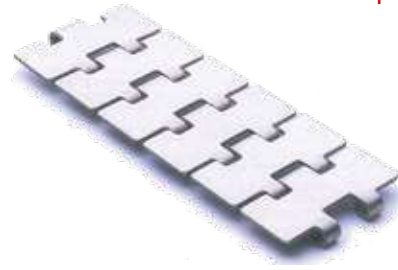

### SPECIAL - Inox

- Ferritic, AISI 430 stainless steel slats, work hardened, with shiny surface having low roughness.
- AISI 431 stainless steel pins, magnetic and work hardened for high resistance.

812  
Series

Chain Ref.	Model	L=Slat width		Hardness	GP	RCC	Weight per metre
		mm.	"	HRC	mm.	mm.	Kg./m.
SSR 812 - K 325	Special	82,5	3 1/4	20	2,8	75	2,55

### STELLA D - Inox 18/8

- Chrome-nickel, austenitic AISI 304 stainless steel slats (18% Chrome - 8% Nickel), work hardened for high resistance - with a roughness of Ra ≤ 0.5 microns.
- Austenitic stainless steel pins (18% Chrome - 8% Nickel), work hardened for high resistance.

815  
Series

Chain Ref.	Model	L=Slat width		Hardness	GP	RCC	Weight per metre
		mm.	"	HRC	mm.	mm.	Kg./m.
SSAR 815 - K 213*	Stella D	54,1	-	26	2,8	75	2,10
SSAR 815 - K 250	Stella D	63,5	2 1/2	26	2,8	75	2,20
SSAR 815 - K 263	Stella D	66,7	2 5/8	26	2,8	75	2,30
SSAR 815 - K 300	Stella D	76,2	3	26	2,8	75	2,45
SSAR 815 - K 325	Stella D	82,5	3 1/4	26	2,8	75	2,60
SSAR 815 - K 335*	Stella D	85,0	-	26	2,8	75	2,68
SSAR 815 - K 350	Stella D	88,9	3 1/2	26	2,8	75	2,70
SSAR 815 - K 500	Stella D	127,0	5	26	2,8	75	3,50

SSA 815 - K 225	Stella D	57,1	2 1/4	26	1,6	150	2,18
SSA 815 - K 250	Stella D	63,5	2 1/2	26	1,6	150	2,25
SSA 815 - K 275	Stella D	69,9	2 3/4	26	1,6	150	2,35
SSA 815 - K 300	Stella D	76,2	3	26	1,6	150	2,50
SSA 815 - K 325	Stella D	82,5	3 1/4	26	1,6	150	2,65
SSA 815 - K 375	Stella D	95,3	3 3/4	26	1,6	150	2,85
SSA 815 - K 400	Stella D	101,6	4	26	1,6	150	3,00
SSA 815 - K 450	Stella D	114,3	4 1/2	26	1,6	150	3,30
SSA 815 - K 600	Stella D	152,4	6	26	1,6	150	4,20
SSA 815 - K 750	Stella D	190,5	7 1/2	26	1,6	150	5,10

### 316 - Inox 316

- Chrome-nickel, austenitic AISI 316L stainless steel slats (18% Chrome - 14% Nickel - 3% Molybdenum).
- Austenitic AISI 316 stainless steel pins.

Chain Ref.	Model	L=Slat width		Hardness	GP	RCC	Weight per metre
		mm.	"	HRC	mm.	mm.	Kg./m.
SSAA 815 - K 325*	316	82,5	3 1/4	-	1,6	150	2,65
SSAA 815 - K 450*	316	114,3	4 1/2	-	1,6	150	3,30
SSAA 815 - K 600*	316	152,4	6	-	1,6	150	4,20
SSAA 815 - K 750*	316	190,5	7 1/2	-	1,6	150	5,10

\*Size produced only upon request.

- Standard shipping lengths = 80 pitches = 10 feet = 3,048 metres.

## Straight running chains - Single hinge

ACCATE - Carbon Steel

- Heat-treated carbon steel slats.
- Case hardened carbon steel pins.



815  
Series

Designation example  
**S** — Material  
**815** — Chain type  
**K 225** — Chain Width

Chain Ref.	Model	L=Slat width		Core Hardness	Surface Hardness	GP	RCC	Weight per metre
		mm.	"					
S 815 - K 225	Accate	57,1	2 1/4	43	43	1,6	150	2,15
S 815 - K 250	Accate	63,5	2 1/2	43	43	1,6	150	2,22
S 815 - K 300	Accate	76,2	3	43	43	1,6	150	2,50
S 815 - K 325	Accate	82,5	3 1/4	43	43	1,6	150	2,65
S 815 - K 400	Accate	101,6	4	43	43	1,6	150	3,00
S 815 - K 450	Accate	114,3	4 1/2	43	43	1,6	150	3,30
S 815 - K 473*	Accate	120,0	-	43	43	1,6	150	3,45
S 815 - K 600	Accate	152,4	6	43	43	1,6	150	4,20
S 815 - K 750	Accate	190,5	7 1/2	43	43	1,6	150	5,10

## "Mignon" straight running chains - Single hinge

812 Mini  
Series

STANDARD - Inox

- Ferritic, AISI 430 stainless steel slats, work hardened, with shiny surface having low roughness.
- AISI 431 stainless steel pins, magnetic and work hardened for high resistance.

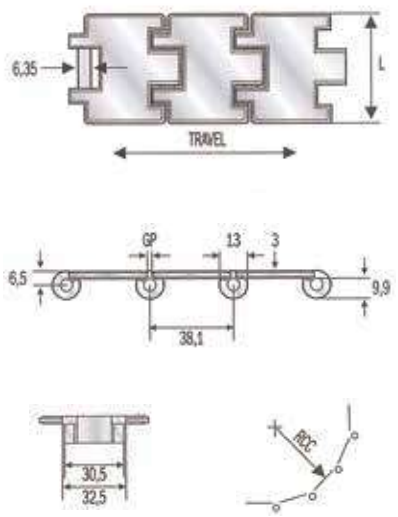
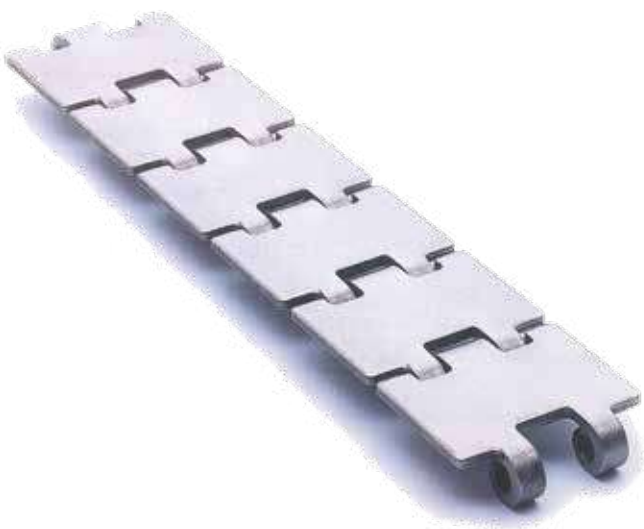

"Mignon" straight running chains  
- Single hinge

# "Mignon" straight running chains - Single hinge

Designation example

SSAR — Material  
812 — Chain type  
K 197 — Chain Width

812 Mini  
Series

## STELLA D - Inox 18/8

- Chrome-nickel, austenitic AISI 304 stainless steel slats (18% Chrome - 8% Nickel), work hardened for high resistance - shiny - with a roughness of  $Ra \leq 0.5$  microns.
- Austenitic stainless steel pins (18% Chrome - 8% Nickel), work hardened for high resistance.

Chain Ref.	Model	L=Slat width		Hardness	GP	RCC	Weight per metre
		mm.	"	HRC	mm.	mm.	Kg./m.

--	--	--	--	--	--	--	--

## SUPER - Hard Inox

- Special, chrome-nickel stainless steel slats, work hardened for high resistance - shiny - with shiny surface having a roughness of  $Ra \leq 0.3$  microns.
- AISI 431 stainless steel pins, magnetic and work hardened for high resistance.

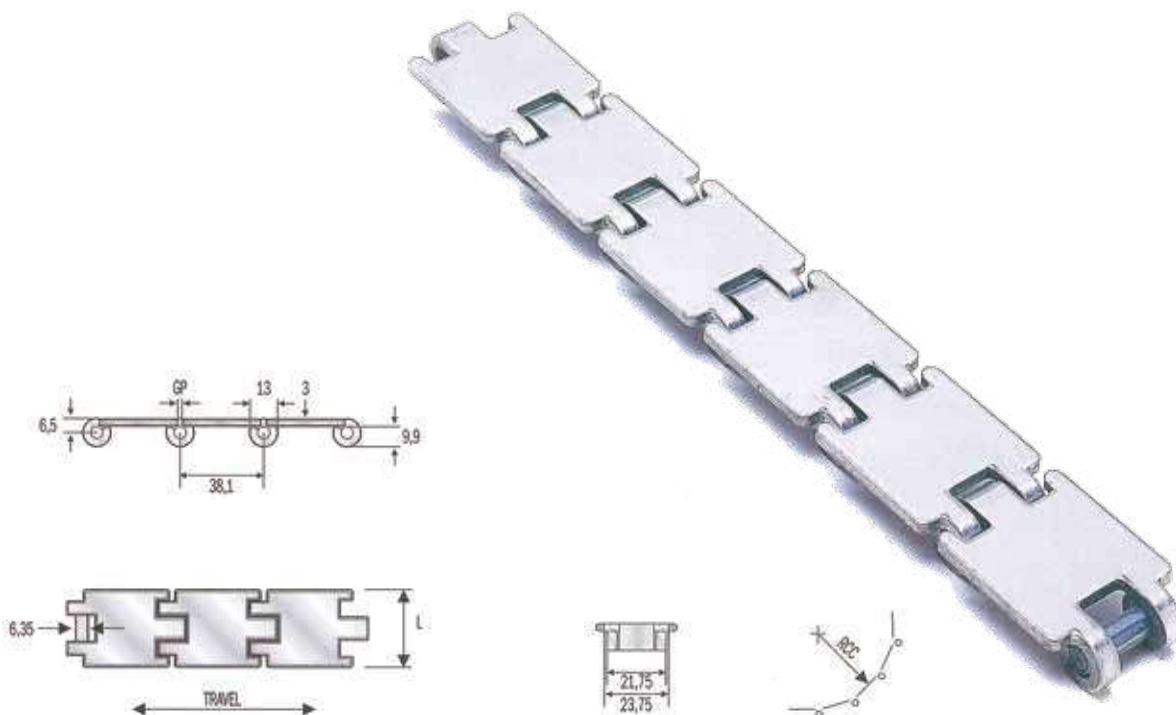

Chain Ref.	Model	L=Slat width		Hardness	GP	RCC	Weight per metre
		mm.	"	HRC	mm.	mm.	Kg./m.
SSHR 812 - K 125	Super	31,8	1 1/4	30	2,8	75	1,10
SSHR 812 - K 175	Super	44,5	1 3/4	30	2,8	75	1,30

- Standard shipping lengths = 80 pitches = 10 feet = 3,048 metres.

802  
Series

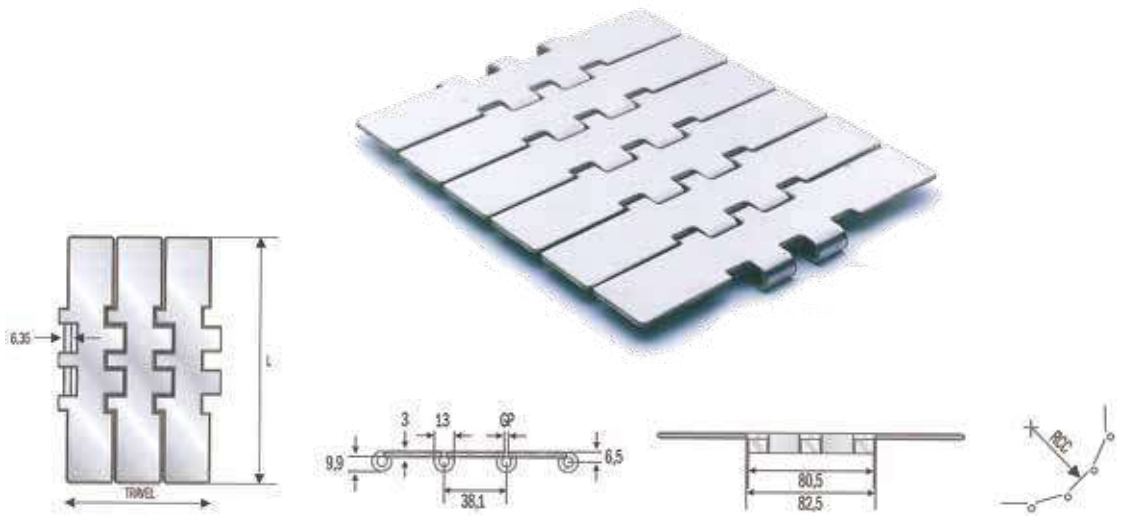

**STANDARD - Inox**

- Ferritic, AISI 430 stainless steel slats, work hardened, with shiny surface having low roughness.
- AISI 431 stainless steel pins, magnetic and work hardened for high resistance.

**SUPER - Hard Inox**

- Special, chrome-nickel stainless steel slats, work hardened for high resistance - shiny - with shiny surface having a roughness of  $Ra \leq 0.3$  microns.
- AISI 431 stainless steel pins, magnetic and work hardened for high resistance.

**STELLA D - Inox 18/8**

- Chrome-nickel, austenitic AISI 304 stainless steel slats (18% Chrome - 8% Nickel), work hardened for high resistance - shiny - with a roughness of  $Ra \leq 0.5$  microns.
- Austenitic stainless steel pins (18% Chrome - 8% Nickel), work hardened for high resistance.

Chain Ref.	Model	L=Slat width		Hardness	GP	RCC	Weight per metre
		mm.	"				
SS 802 - K 750	Standard	190,5	7 1/2	20	1,6	150	5,80
SSH 802 - K 750	Super	190,5	7 1/2	30	1,6	150	5,80
SSA 805 - K 750	Stella D	190,5	7 1/2	26	1,6	150	5,80

**Designation example**

SS — Material  
802 — Chain type  
K 750 — Chain Width

Sideflexing hinged slat chains

**ACCATE - Carbon Steel**

- Heat-treated carbon steel slats, with a surface and core of 43 HRC.
- Case hardened carbon steel pins.



Chain Ref.	Model	L=Slat width		Hardness	GP	RCC	Weight per metre
		mm.	"				
S 802 - K 750	Accate	190,5	7 1/2	43	1,6	150	5,80

— Standard shipping lengths = 80 pitches = 10 feet = 3,048 metres.



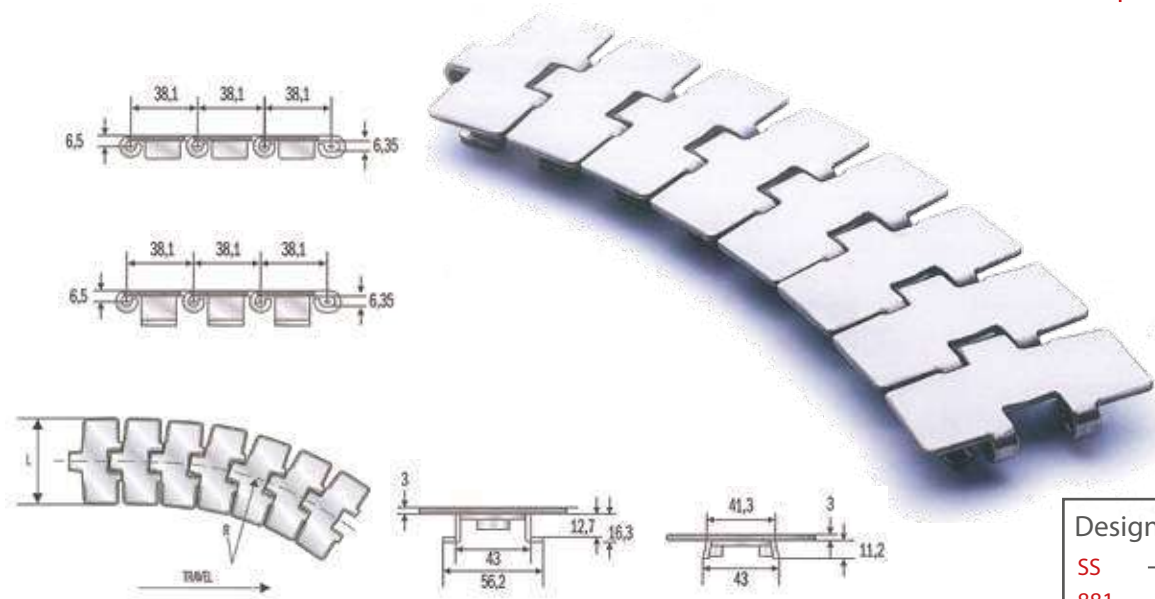

Designation example  
 SS — Material  
 881 — Chain type  
 K 325 — Chain Width

### FLEX RXMC - Inox

- Ferritic, AISI 430 stainless steel slats, work hardened, with shiny surface having low roughness.
- Chrome-nickel, austenitic stainless steel guide shoes (18% Chrome - 8% Nickel), work hardened for high resistance.
- AISI 431 stainless steel pins, magnetic and work hardened for high resistance.

### FLEX RXMS - Hard Inox

- Special, chrome-nickel stainless steel slats, work hardened for high resistance, with shiny surface having a roughness of  $R_a \leq 0.3$  microns.
- Chrome-nickel, austenitic stainless steel guide shoes (18% Chrome - 8% Nickel), work hardened for high resistance.
- AISI 431 stainless steel pins, magnetic and work hardened for high resistance.

Chain Ref.	Model	L=Slat width		R=Minimum sideflexing radius	Weight per metre
		mm.	"	mm.	Kg./m.
SS 881 T - K 325	Flex RXMC TAB	82,5	3 1/4	457	3,10

SSH 881 - K 325	Flex RXMC 8	82,5	3 1/4	457	2,90
SSH 881 - K 450	Flex RXMC 8	114,3	4 1/2	500	3,60
SSH 881 - K 750	Flex RXMC 8	190,5	7 1/2	500	5,30
SSH 881 T - K 325	Flex RXMC TAB	82,5	3 1/4	457	3,10
SSH 881 T - K 450	Flex RXMC TAB	114,3	4 1/2	500	3,80
SSH 881 T - K 750	Flex RXMC TAB	190,5	7 1/2	500	5,50

– Standard shipping lengths = 80 pitches = 10 feet = 3,048 metres.

### FLEX RXM - Inox 18/8

- Chrome-nickel austenitic AISI 304 stainless steel slats (18% Chrome - 8% Nickel), work hardened for high resistance - shiny with a roughness of  $R_a \leq 0.5$  microns.
- Chrome-nickel, austenitic stainless steel guide shoes (18% Chrome - 8% Nickel), work hardened for high resistance.
- Austenitic stainless steel pins (18% Chrome - 8% Nickel), work hardened for high resistance.

881  
Series



**FLEX RXM - Inox 316**

- Chrome-nickel, austenitic AISI 304 stainless steel slats (18% Chrome - 8% Nickel), work hardened for high resistance - shiny - with a roughness of  $Ra \leq 0.5$  microns.
- Austenitic stainless steel pins (18% Chrome - 8% Nickel), work hardened for high resistance.

**FLEX - RXMA - Carbon Steel**

- Heat-treated carbon steel slats, with a surface and core of 43 HRC.
- Case hardened carbon steel pins.

Designation example

SSA — Material  
881 — Chain type  
K 325 — Chain Width

Chain Ref.	Model	L=Slat width		R=Minimum sideflexing radius	Weight per metre
		mm.	"	HRC	
SSA 881 - K 325	Flex RXM 8	82,5	3 1/4	457	2,90
SSA 881 - K 450	Flex RXM 8	114,3	4 1/2	500	3,60
SSA 881 - K 750	Flex RXM 8	190,5	7 1/2	500	5,30
SSA 881 T - K 325	Flex RXM 8	82,5	3 1/4	457	3,10
SSA 881 T - K 450	Flex RXM 8	114,3	4 1/2	500	3,80
SSA 881 T - K 750	Flex RXM 8	190,5	7 1/2	500	5,50

SSAA 881 T - K 325	Flex RXM 316 TAB	82,5	3 1/4	457	3,10
SSAA 881 T - K 450	Flex RXM 316 TAB	114,3	4 1/2	500	3,80
SSAA 881 T - K 750	Flex RXM 316 TAB	190,5	7 1/2	500	5,50

S 881 - K 325	Flex RXMA 8	82,5	3 1/4	457	2,90
S 881 - K 450	Flex RXMA 8	114,3	4 1/2	500	3,60
S 881 - K 750	Flex RXMA 8	190,5	7 1/2	500	5,30
S 881 T - K 250	Flex RXMA TAB	63,5	2 1/2	457	2,65
S 881 T - K 325	Flex RXMA TAB	82,5	3 1/4	457	3,10
S 881 T - K 450	Flex RXMA TAB	114,3	4 1/2	500	3,80
S 881 T - K 750	Flex RXMA TAB	190,5	7 1/2	500	5,50

— Standard shipping lengths = 80 pitches = 10 feet = 3,048 metres.

Sideflexing hinged slat chains

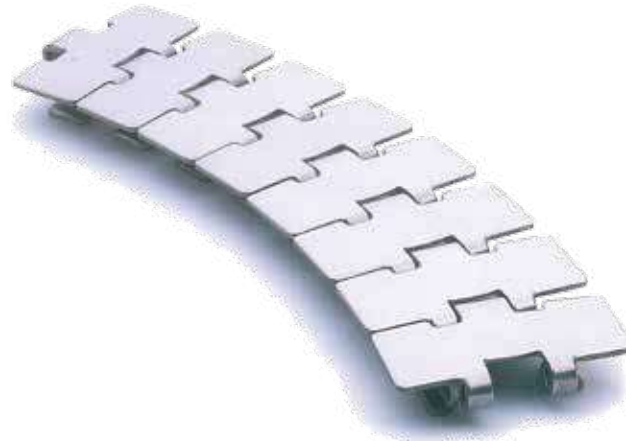

8811  
Series

**Designation example**

SSH — Material  
8811 — Chain type  
K 325 — Chain Width

**FLEX RXM - Inox 18/8**

- Chrome-nickel austenitic AISI 304 stainless steel slats (18% Chrome - 8% Nickel), work hardened for high resistance - shiny with a roughness of  $R_a \leq 0.5$  microns.
- Chrome-nickel, austenitic stainless steel guide shoes (18% Chrome - 8% Nickel), work hardened for high resistance.
- Austenitic stainless steel pins (18% Chrome - 8% Nickel), work hardened for high resistance.

**FLEX FMD - Hard Inox**

- Special, new stainless steel, chrome-nickel (W.1.4589) slats, work hardened for high resistance, with low surface roughness,  $R_a \leq 0.3$  microns.
- Chrome-nickel, austenitic stainless steel guide shoes (18% Chrome - 8% Nickel), work hardened for high resistance.
- Special martensitic stainless steel pins, magnetic and heat treated for high resistance.

**FLEX FMD - Inox 18/8**

- Chrome-nickel austenitic AISI 304 stainless steel slats (18% Chrome - 8% Nickel), work hardened for high resistance - shiny with a roughness of  $R_a \leq 0.5$  microns.
- Chrome-nickel, austenitic stainless steel guide shoes (18% Chrome - 8% Nickel), work hardened for high resistance.
- Austenitic stainless steel pins (18% Chrome - 8% Nickel), work hardened for high resistance.

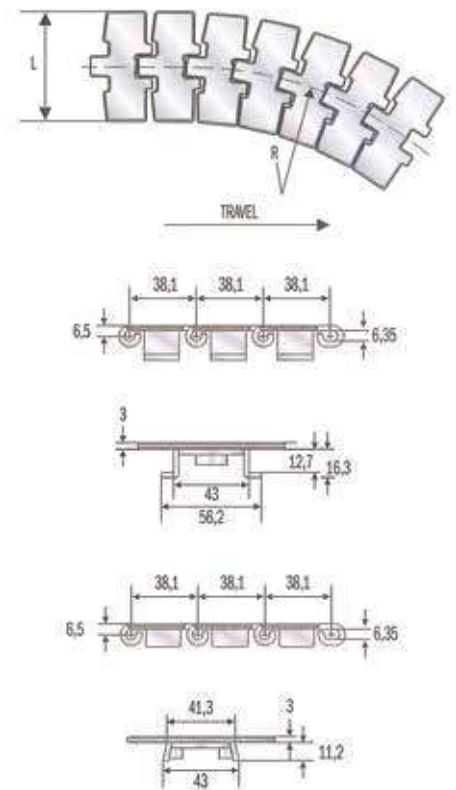

Chain Ref.	Model	L=Slat width		R=Minimum sideflexing radius	Weight per metre
		mm.	"	mm.	Kg./m.
SSH 8811 - K 325	Flex FMS 8	82,5	3 1/4	500	2,90
SSH 8811 - K 350	Flex FMS 8	88,9	3 1/2	500	3,10
SSH 8811 T - K 325	Flex FMS TAB	82,5	3 1/4	500	3,10
SSH 8811 T - K 350	Flex FMS TAB	88,9	3 1/2	500	3,30

SSX 8811 - K 325	Flex FMD TAB	82,5	3 1/4	500	3,10
------------------	--------------	------	-------	-----	------

SSA 8811 - K 325	Flex FM 8	82,5	3 1/4	500	2,90
SSA 8811 - K 350	Flex FM 8	88,9	3 1/2	500	3,10
SSA 8811 T - K 325	Flex FM TAB	82,5	3 1/4	500	3,10
SSA 8811 T - K 350	Flex FM TAB	88,9	3 1/2	500	3,30

– Standard shipping lengths = 80 pitches = 10 feet = 3,048 metres.

881 Radius Series



FLEX FMS2 R=200 mm. - Hard Inox

- Chrome-nickel austenitic AISI 304 stainless steel slats (18% Chrome - 8% Nickel), work hardened for high resistance - shiny with a roughness of  $Ra \leq 0.5$  microns.
- Chrome-nickel, austenitic stainless steel guide shoes (18% Chrome - 8% Nickel), work hardened for high resistance.
- Austenitic stainless steel pins (18% Chrome - 8% Nickel), work hardened for high resistance.

Designation example

SSH — Material  
881 R — Chain type  
TK 325 — Chain Width

FLEX FM2 R=200 mm. - Inox 18/8

- Chrome-nickel austenitic AISI 304 stainless steel slats (18% Chrome - 8% Nickel), work hardened for high resistance - shiny with a roughness of  $Ra \leq 0.5$  microns.
- Chrome-nickel, austenitic stainless steel guide shoes (18% Chrome - 8% Nickel), work hardened for high resistance.
- Austenitic stainless steel pins (18% Chrome - 8% Nickel), work hardened for high resistance.

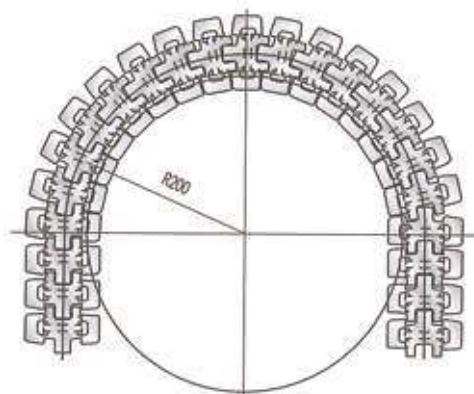
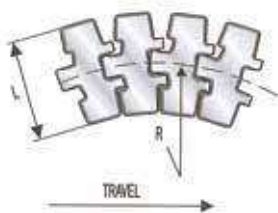
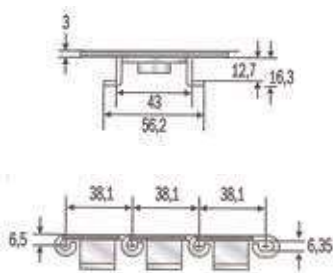

Sideflexing hinged slat chains

Chain Ref.	Model	L=Slat width		R=Minimum sideflexing radius	Weight per metre
		mm.	"	mm.	Kg./m.
SSH 881 RT - K 325	Flex FMS2 TAB	82,5	3 1/4	200	3,00
SSA 881 RT - K 325	Flex FM2 TAB	82,5	3 1/4	200	3,00

– Standard shipping lengths = 80 pitches = 10 feet = 3,048 metres.  
Not to be used with lateral curving discs.

# Sideflexing hinged slat chains for magnetic systems

881 Magnet  
Series



## NEW FLEX MAG - Hard Inox

- Special, chrome-nickel, stainless steel slats, work hardened for high resistance - with shiny surface having a roughness of  $Ra \leq 0.3$  microns.
- Special, stainless steel pins, 400 series - magnetic - work hardened for high resistance.

## NEW FLEX MAG D - HQ Inox

- Special, new stainless steel, chrome-nickel (W.1.4589) slats, work hardened for high resistance with very little roughness of  $Ra \leq 0.2$  microns.
- Special martensitic stainless steel pins, magnetic and heat treated for high resistance.

### Designation example

SSH — Material  
881 M — Chain type  
K 325 — Chain Width

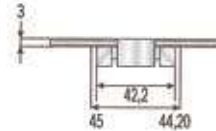
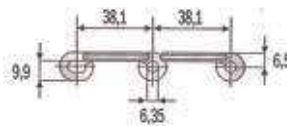

Chain Ref.	Model	L=Slat width		R=Minimum sideflexing radius	Weight per metre
		mm.	"		
SSH 881 M - K 325	New Flex Mag	82,5	3 1/4	500	2,50
SSH 881 M - K 450	New Flex Mag	114,3	4 1/2	500	3,20
SSH 881 M - K 750	New Flex Mag	190,5	7 1/2	500	4,90
SSX 881 M - K 325	New Flex Mag-D	82,5	3 1/4	500	2,50

– Standard shipping lengths = 80 pitches = 10 feet = 3,048 metres.

812 Friction Series

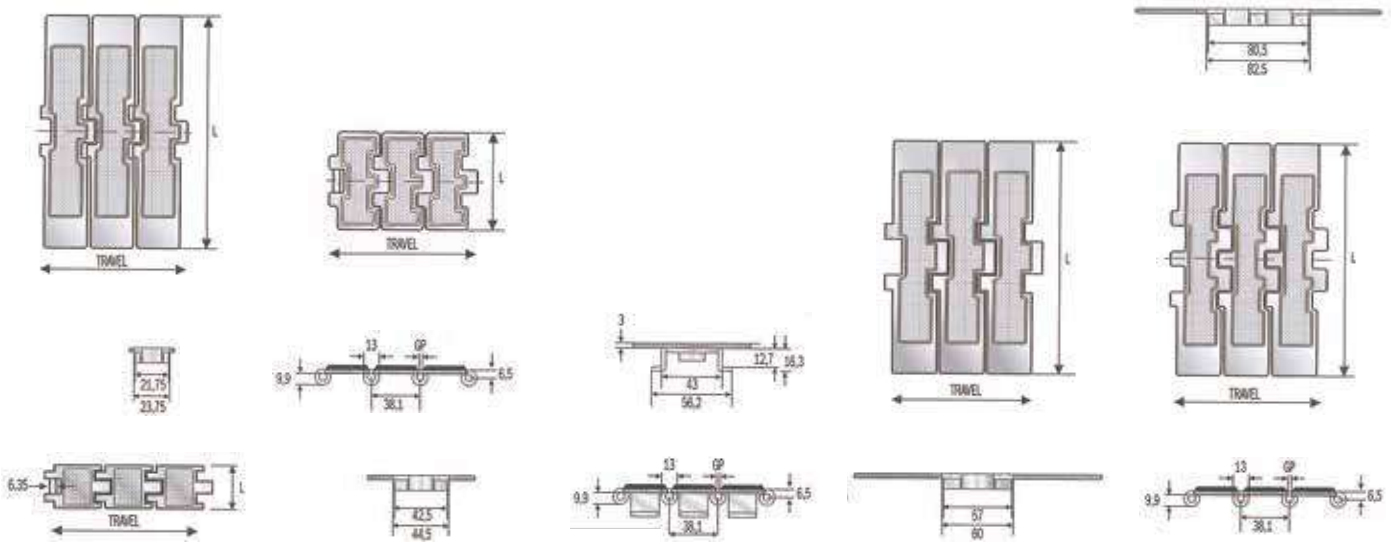
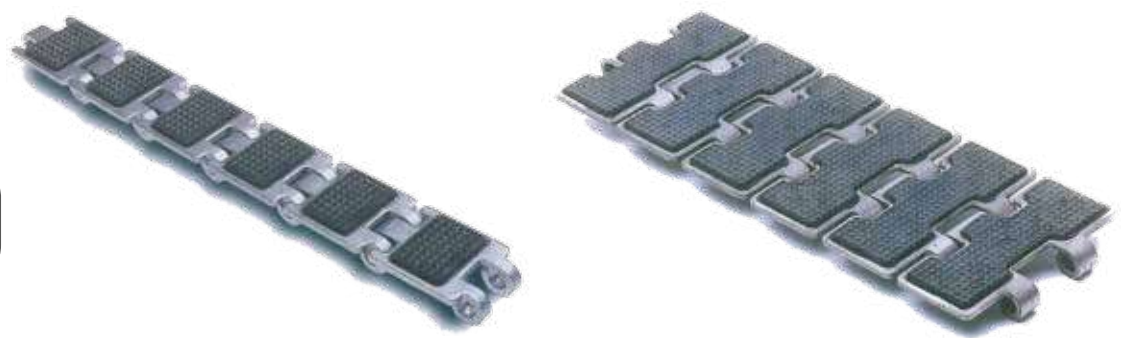

**SUPER-G/DHG - Hard Inox**

- Special, chrome-nickel, stainless steel slats, work hardened for high resistance, with rubber insert.
- Chrome-nickel, austenitic stainless steel guide shoes (18% Chrome - 8% Nickel), (Super-G TAB).
- AISI 431 stainless steel pins, magnetic and work hardened for high resistance.

**Designation example**

- SSHR — Material
- 812 G — Chain type
- K 125 — Chain Width

Straight running chains with rubber inserts for inclined conveyors

Chain Ref.	Model	L=Slat width		Hardness	GP	RCC	Weight per metre
		mm.	"				
SSHR 812 G - K 125	Super-G	31,8	1 1/4	30	2,8	75	1,20
SSHR 812 G - K 325	Super-G	82,5	3 1/4	30	2,8	75	2,80
SSHR 812 T G - K 325	Super-G	82,5	3 1/4	30	2,8	75	3,40
SSH 812 G - K 450	Super-G	114,3	4 1/2	30	1,6	150	3,50
SSH 812 G - K 600	Super-G	152,4	6	30	1,6	150	4,40
SSH 812 G - K 750	Super-G	190,5	7 1/2	30	1,6	150	5,30
SSH 8127 G - K 750	Super-G	190,5	7 1/2	30	1,6	150	5,35
SSH 802 G - K 750	Super-DHG	190,5	7 1/2	30	1,6	150	6,20

— Standard shipping lengths = 80 pitches = 10 feet = 3,048 metres.

# Sideflexing hinged slat chains with rubber inserts for inclined conveyors

881 Friction Series

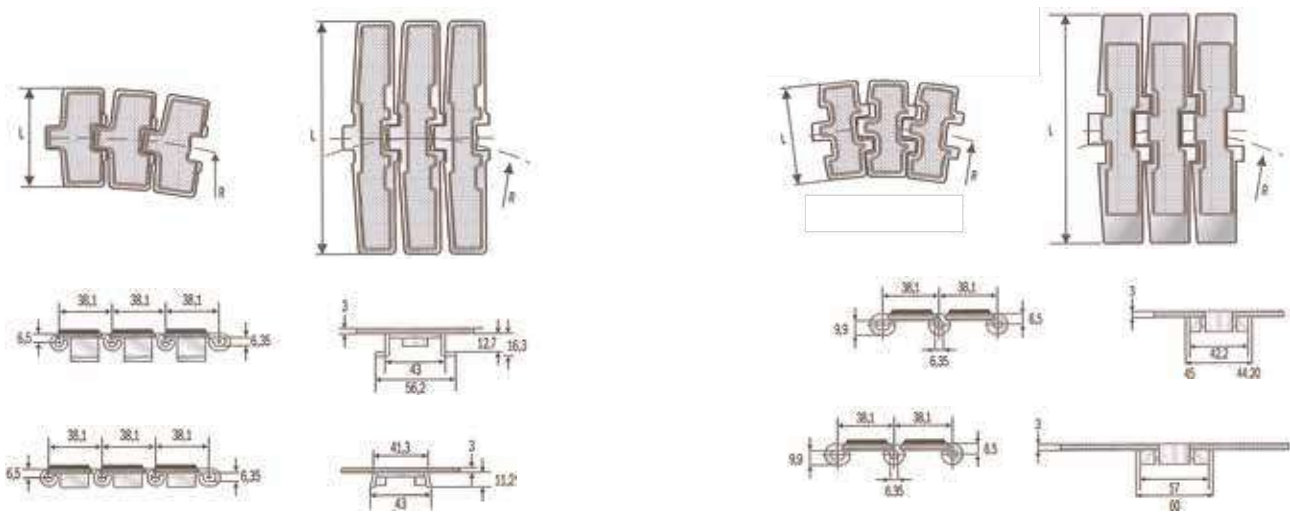

## FLEX RXMS-G NEW FLEX-G MAG - Hard Inox

- Special, chrome-nickel, stainless steel slats, work hardened for high resistance, with a rubber insert.
- Chrome-nickel, austenitic stainless steel guide shoes (18% Chrome - 8% Nickel), (Flex RXMS-G).
- Special, stainless steel pins, 400 series - magnetic - work hardened for high resistance.

### Designation example

- SSH — Material  
881 G — Chain type  
K 325 — Chain Width

Chain Ref.	Model	L=Slat width		R=Minimum sideflexing radius	Weight per metre
		mm.	"	mm.	Kg./m.
SSH 881 G - K 325	Flex RXMS-G 8	82,5	3 1/4	457	3,10
SSH 881 G - K 450	Flex RXMS-G 8	114,3	4 1/2	500	3,80
SSH 881 G - K 750	Flex RXMS-G 8	190,5	7 1/2	500	5,50
SSH 881 T G - K 325	Flex RXMS-G TAB	82,5	3 1/4	457	3,30
SSH 881 T G - K 450	Flex RXMS-G TAB	114,3	4 1/2	500	4,00
SSH 881 T G - K 750	Flex RXMS-G TAB	190,5	7 1/2	500	5,70
SSH 881 M G - K 325	New Flex-G Mag	82,5	3 1/4	500	2,70
SSH 881 M G - K 750	New Flex-G Mag	190,5	7 1/2	500	5,10
SSH 8817 M G - K 750	New Flex-G Mag	190,5	7 1/2	860	5,14

– Standard shipping lengths = 80 pitches = 10 feet = 3,048 metres.

Sideflexing hinged slat chains with rubber inserts for inclined conveyors

1864 Series



1864 SERIES

This high speed, high capacity series offers better efficiency and reliability in applications where high temperatures or abrasive materials are involved.

- Steel and stainless steel top plates.
- Base roller chain, 19,05 mm - 3/4" pitch.

Designation example  
 1864 SS — Chain type  
 K 325 — Chain Width

Chain Ref.	Ultimate strength	Base chain material	Top plate material	L=Slat width	Weight per metre
	N			mm.	Kg./m.
1864 - K 325	37000	Carbon	Carbon	82,5	3,33
1864 - K 450			Steel	114,3	4,00
1864 - K 600		Steel	152,4	5,33	
1864 - K 750		Steel	190,5	5,68	

1864 A - K 325	37000	Carbon	Stainless	82,5	3,33
1864 A - K 450			Steel	114,3	4,00
1864 A - K 600		Steel	152,4	5,33	
1864 A - K 750		Steel	190,5	5,68	

1864 SS - K 325	26000	Stainless	Stainless	82,5	3,33
1864 SS - K 450			Steel	114,3	4,00
1864 SS - K 600		Steel	152,4	5,33	
1864 SS - K 750		Steel	190,5	5,68	

– Standard shipping lengths = 80 pitches = 10 feet = 3,048 metres.

"1864" Straight running Plate Top chains



# "1874" Sideflexing Plate Top chains

1874  
Series

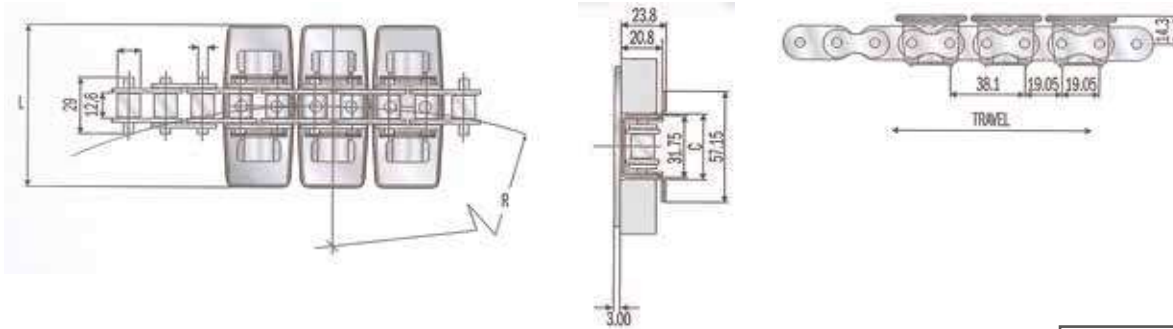

## 1874 SERIES

This high speed, high capacity series offers better efficiency and reliability in applications where high temperatures or abrasive materials are involved.

- Steel and stainless steel top plates.
- Base roller chain, 19,05 mm - 3/4" pitch.

Designation example  
**1874 A** — Chain type  
**K 325** — Chain Width

Chain Ref.	Ultimate strength	Base chain material	Top plate material	L=Slat width	Straight C	Curve C	R=Minimum sideflexing radius	Weight per metre
	N			mm.	mm.	mm.	mm.	Kg./m.
1874 - K 325	27000	Steel	Steel	82,5	34,1	34,6	356	4,20
1874 - K 450				114,3				4,80
1874 - K 600				152,4				5,70
1874 - K 750				190,5				6,40

1874 A - K 325	27000	Steel	Stainless	82,5	34,1	34,6	356	4,20
1874 A - K 450				114,3				4,80
1874 A - K 600				152,4				5,70
1874 A - K 750				190,5				6,40

1874 SS - K 325	21000	Stainless	Stainless	82,5	34,1	34,6	356	4,20
1874 SS - K 450				114,3				4,80
1874 SS - K 600				152,4				5,70
1874 SS - K 750				190,5				6,40

– Standard shipping lengths = 80 pitches = 10 feet = 3,048 metres.

Reinforced polyamide + screws in stainless steel.

SPROCKETS  
815  
812

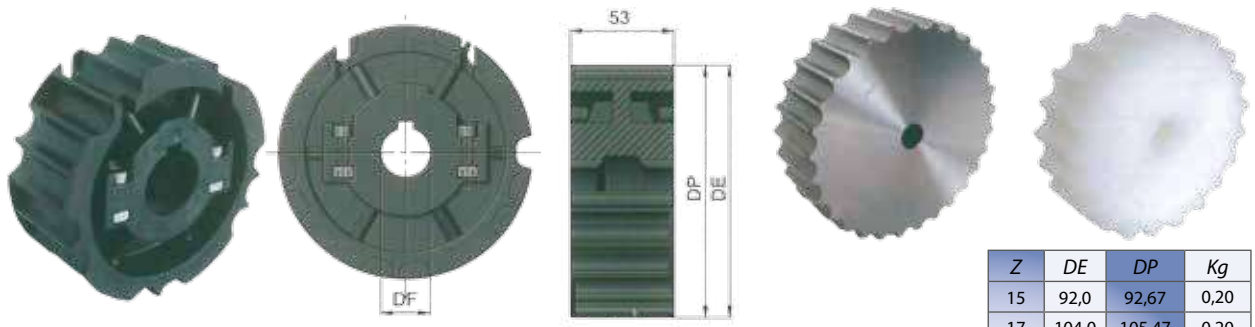

Z	DE	DP	Kg
15	92,0	92,67	0,20
17	104,0	105,47	0,20
19	117,0	117,34	0,30
21	129,0	129,26	0,40
23	141,0	141,22	0,50
25	153,0	153,20	0,60
27	165,0	165,21	0,80
29	177,0	177,23	1,00

Reinforced polyamide + screws in stainless steel.

SPROCKETS  
820  
831

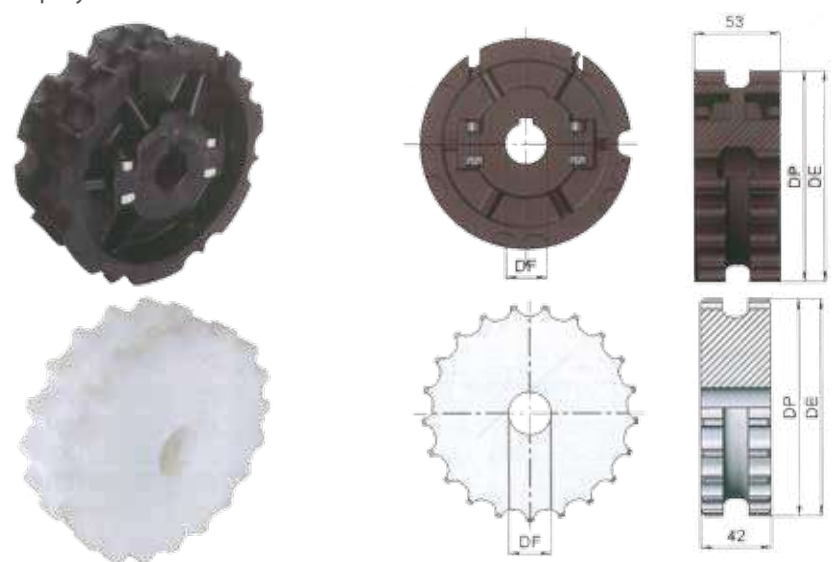

Z	DE	DP	Kg
15	92,0	92,67	0,18
17	104,0	105,47	0,18
19	117,0	117,34	0,28
21	129,0	129,26	0,38
23	141,0	141,22	0,48
25	153,0	153,20	0,58
27	165,0	165,21	0,78
29	177,0	177,23	0,98



Reinforced polyamide + screws in stainless steel.

SPROCKETS  
805  
821

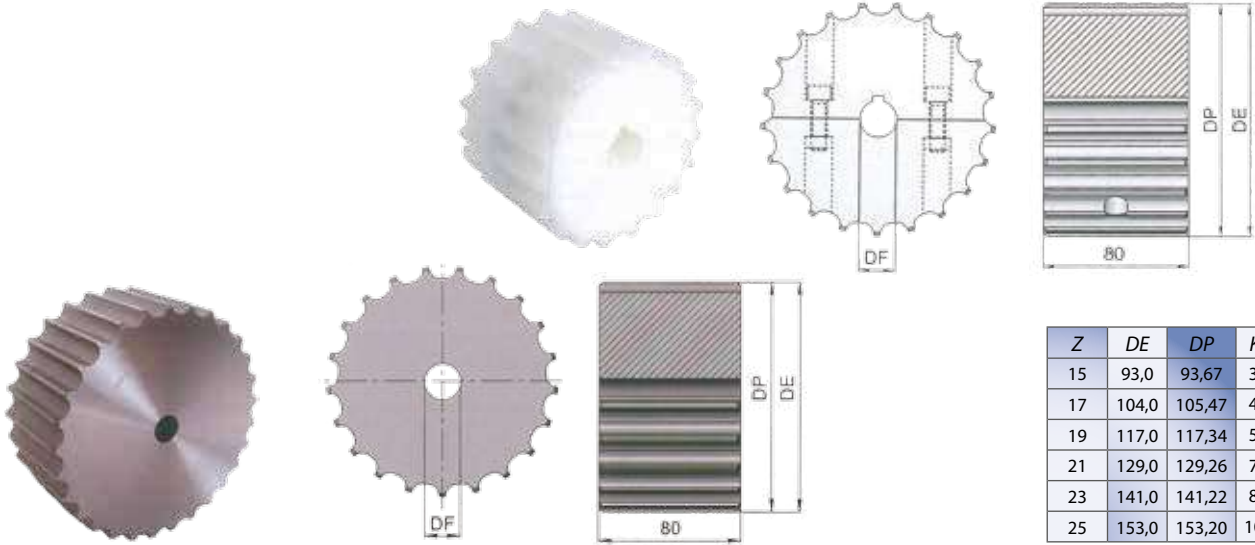

Z	DE	DP	Kg
15	93,0	93,67	3,5
17	104,0	105,47	4,6
19	117,0	117,34	5,8
21	129,0	129,26	7,2
23	141,0	141,22	8,6
25	153,0	153,20	10,2

Reinforced polyamide + screws in stainless steel.

SPROCKETS  
880



Z	DE	DP	DF	Kg
12	147,2	147,21	25	0,39
			30	
			35	
			40	

Z	DE	DP	DF	Kg
12	147,2	147,21	25	0,39
			30	
			35	
			40	

Z	DE	DP	Kg
9	108,50	111,4	0,2
10	120,50	123,29	0,2
11	134,0	135,23	0,3
12	147,2	147,21	0,4

Reinforced polyamide + screws in stainless steel.

SPROCKETS  
881



Z	DE	DP	DF	Kg
19	117,0	117,34	25	0,30
			30	
			35	
			40	
21	129,0	129,26	25	0,40
			30	
			35	
			40	
23	141,0	141,22	25	0,50
			30	
			35	
			40	
25	153,0	153,20	25	0,60
			30	
			35	
			40	

Sprockets

Reinforced polyamide + screws in stainless steel.

**SPROCKETS**  
882

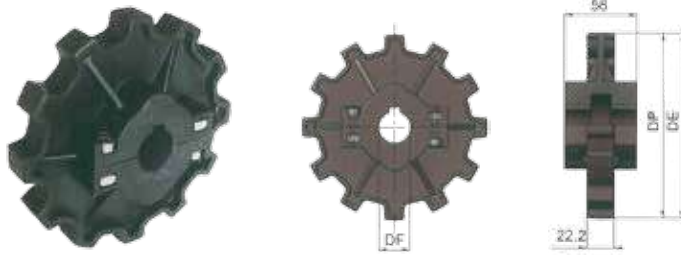

Z	DE	DP	DF	Kg
12	148,5	147,2	25	0,38
			30	
			35	
			40	
			45	

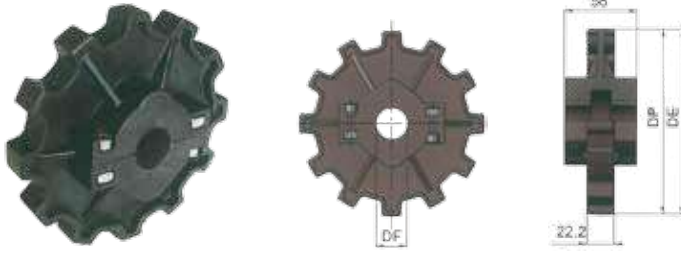

Z	DE	DP	DF	Kg
12	148,5	147,2	25	0,38
			30	
			35	
			40	
			45	

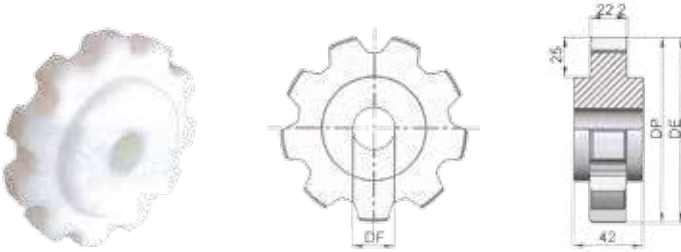

Z	DE	DP	DF	Kg
9	112,5	111,4	25	0,20
			30	
			35	
			40	
10	124,9	123,4	25	0,26
			30	
			35	
			40	
11	136,4	135,2	25	0,33
			30	
			35	
			40	
12	148,5	147,2	25	0,41
			30	
			35	
			40	

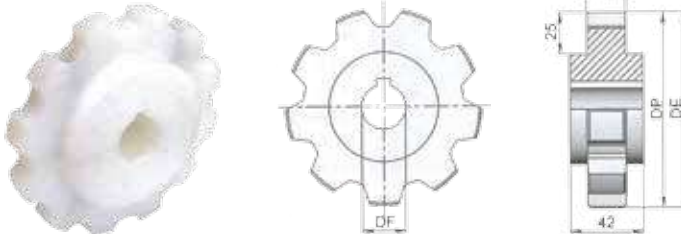

Reinforced polyamide + screws in stainless steel.

**TURN-DISK**

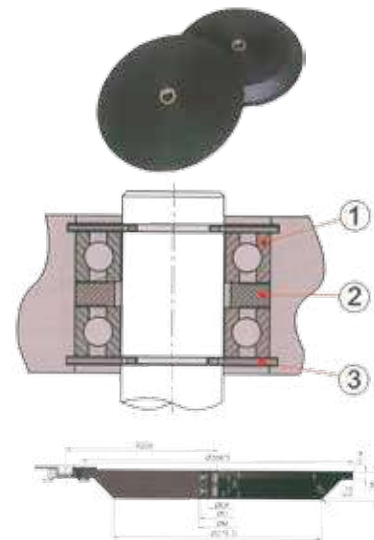

ØDF	ØD	ØM	H	Kg
25	47	51	6	2,20
30	55	60	3	2,20

1. DF25/ DF30: Bearing 6005 ZZ, pcs: 2
2. DF25: Bearings spacer Ø30 x Ø47 x 6, pcs: 1  
DF30: Bearings spacer Ø35 x Ø55 x 3, pcs: 1

3. DF25: DIN 472 J47, pcs: 2
4. DF25: DIN 472 J55, pcs: 2

Reinforced polyamide + screws in stainless steel.

SPROCKETS  
1700

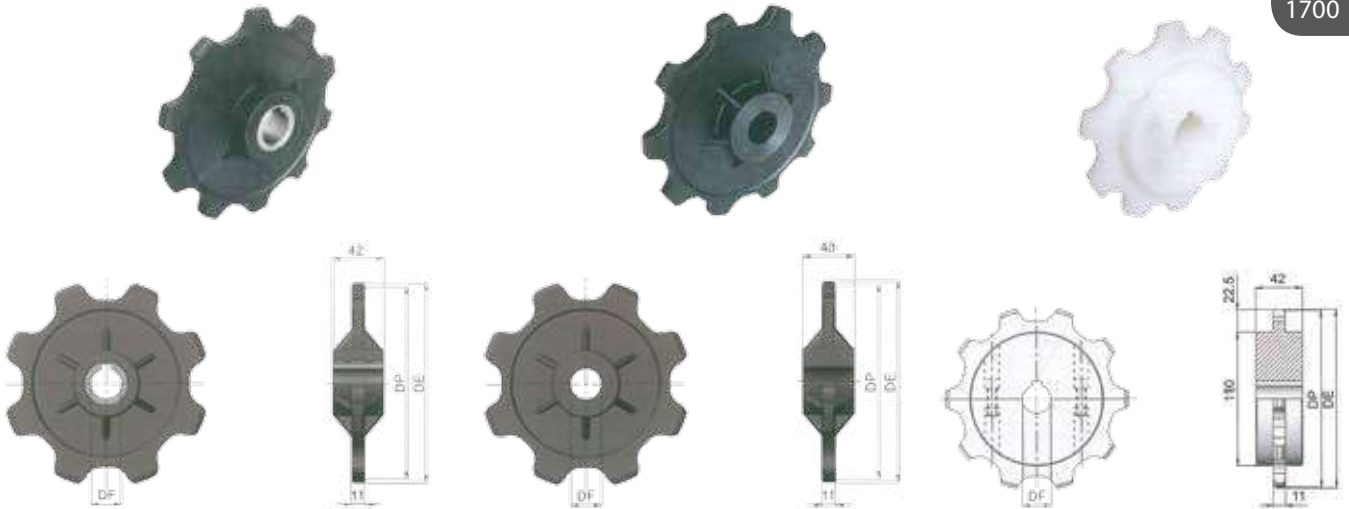

Z	DE	DP	DF	Kg
8	134	130,5	25	0,36
			30	0,40
10	165	161,8	25	0,43
			30	0,47

Z	DE	DP	DF	Kg
8	134	130,5	25	0,18
			30	
10	165	161,8	25	0,28
			30	

Z	DE	DP	DF	Kg
10	165	161,8	25*	0,8
			25	
			30	
			35	
			40	

\* Without key way

Reinforced polyamide + stainless steel.

SPROCKETS  
CC 600

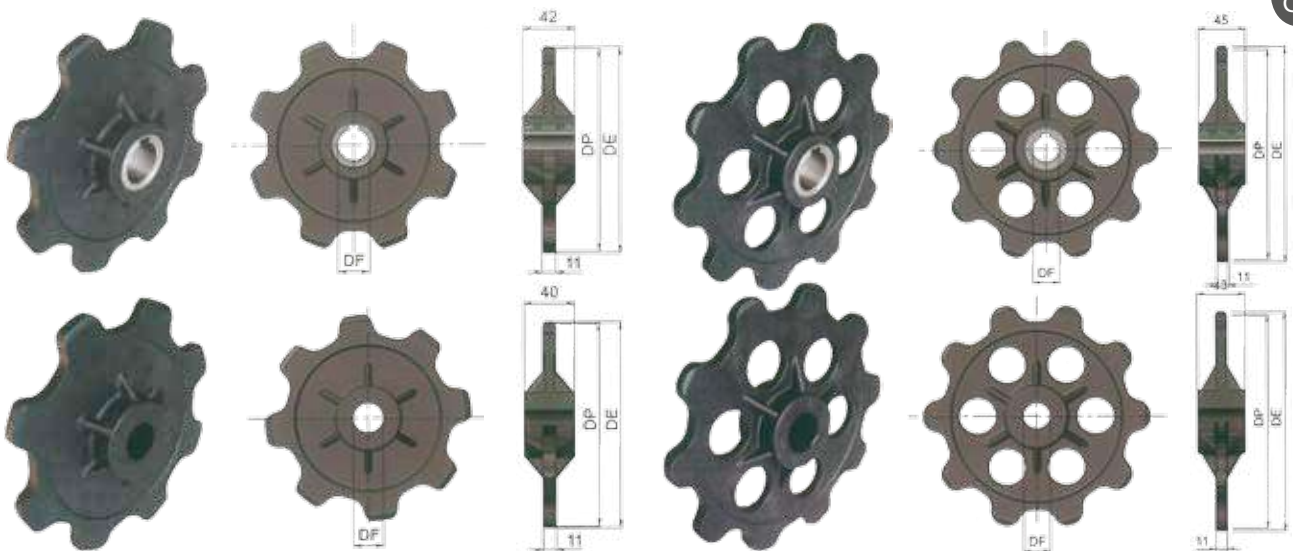

Z	DE	DP	DF	Kg
8	172	166	25	0,51
			30	0,56

Z	DE	DP	DF	Kg
10	215	205,45	25	0,43
			30	0,39

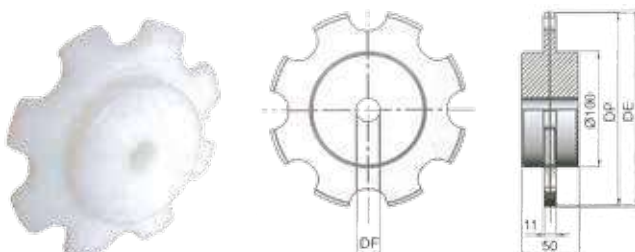

Z	DE	DP	Kg
8	172	165,93	0,600
10	215	205,49	0,800
12	256	245,35	1,100

Low friction/ Acetal.

- Idlers
- 815/820
- 831
- 879
- 880
- 881
- 881 M

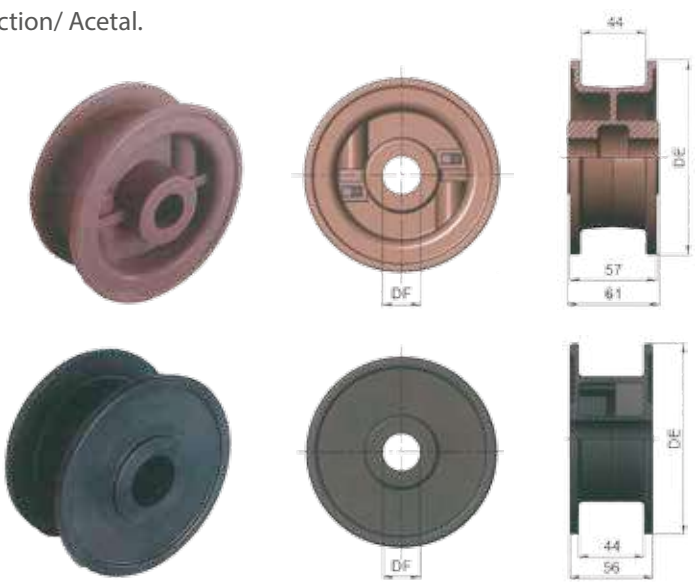

Z	DE	DP	Kg
19	117,0	-	0,2
21	129,0	-	0,2
23	141,0	-	0,3
25	153,0	-	0,3

Acetal.

- Idlers
- 879 TAB
- 880 TAB
- 880 BO
- 881 TAB

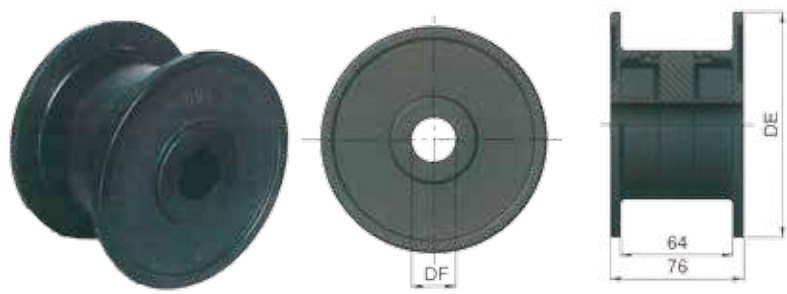

Z	DE	DP	DF	Kg
19	117,0	-	25	0,3
			30	
			35	
			40	
21	129,0	-	25	0,3
			30	
			35	
			40	
23	141,0	-	25	0,3
			30	
			35	
			40	
25	153,0	-	25	0,4
			30	
			35	
			40	

Acetal.

- Idlers
- 805

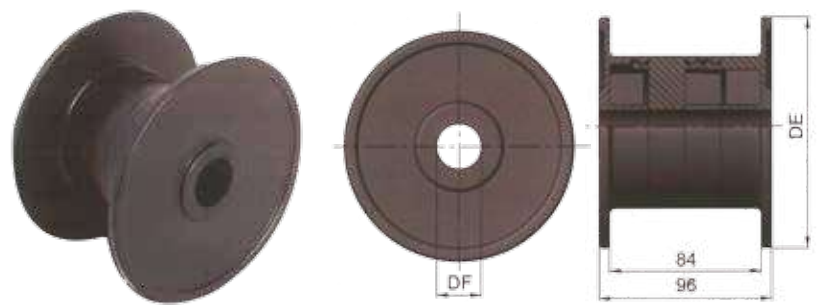

Z	DE	DP	DF	Kg
19	117,0	-	25	0,3
			30	
			35	
			40	
21	129,0	-	25	0,3
			30	
			35	
			40	
23	141,0	-	25	0,3
			30	
			35	
			40	
25	153,0	-	25	0,4
			30	
			35	
			40	

Idlers

Acetal.

Z	DE	DP	DF	Kg
19	117,0	-	25	0,3
			30	
			35	
			40	
21	129,0	-	25	0,3
			30	
			35	
			40	
23	141,0	-	25	0,3
			30	
			35	
			40	
25	153,0	-	25	0,4
			30	
			35	
			40	

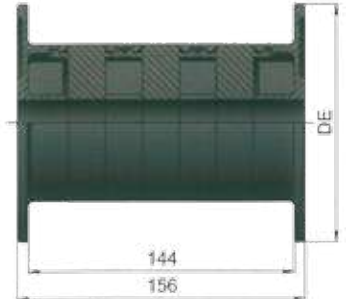

Idlers  
821

Reinforced polyamide.

Z	DE	DP	DF	Kg
17	104	-	20	0,4
			25	
			30	
			35	
			40	
19	117,0	-	20	0,5
			25	
			30	
			35	
			40	
21	129,0	-	20	0,6
			25	
			30	
			35	
			40	
23	141,0	-	20	0,7
			25	
			30	
			35	
			40	
25	153,0	-	20	0,9
			25	
			30	
			35	
			40	

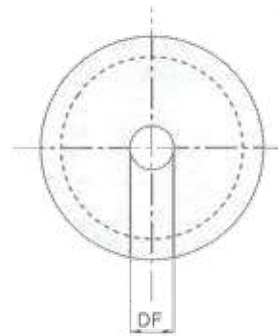

Idlers  
815  
820  
831  
879  
880  
881  
881 M

Reinforced polyamide.

Z	DE	DP	DF	Kg
17	104	-	20	0,6
			25	
			30	
			35	
			40	
19	117,0	-	20	0,8
			25	
			30	
			35	
			40	
21	129,0	-	20	1,0
			25	
			30	
			35	
			40	
23	141,0	-	20	1,2
			25	
			30	
			35	
			40	
25	153,0	-	20	1,4
			25	
			30	
			35	
			40	

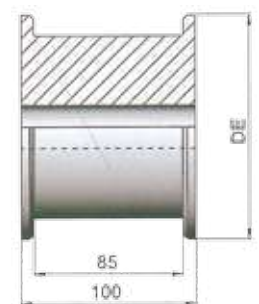
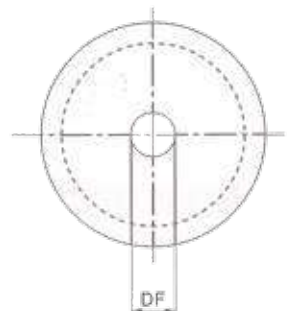

Idlers  
805

We are the leading distributor of Thermoplastic bearing units from ANB.

There are many reasons to use ANB housings, such as:

- 100% corrosion resistant PBT reinforced material.
- 100% plain mounting surface to avoid debris getting trapped.
- Stainless steel greasing nipple.
- All seals and caps with stainless springs.
- FDA & FSDA approved.
- 100% smooth surface for minimized bacteria growth.
- Stainless and seamless insert reinforcements in the mounting holes.
- Caps DO NOT FALL OFF.
- 100% interchangeable with cast iron units.
- Temperatures from -35 to 102 degrees C.

**We supply the ANB housings from stock in Green, White and Black colour.**

Units can either be assembled with High-Quality bearings or "Economy" bearings.

3D drawings available upon request.





You can choose between ANB inserts or "Economy" inserts (SSUC)

### Technical data

- No corrosion
- FDA&FSDA approval
- From 12 to 50 mm.
- Interchangeable with cast iron standards units
- Maintenance free
- Temperature work from - 35 to 102 degree
- Tensile strength at break (ASTM 0630) is an impressive 17.300 PSI
- Excellent mechanical strengths stiffness and dimension stability
- Stainless Steel greaser and inserts
- Solid base prevents dirt and bacteria
- Reliable

### Options

- Closed covers
- Open covers (with Stainless Steel spring)
- Back seals
- Color

### Bearing inserts

- Stainless Steel type MUC
- Stainless Steel type MB
- Steel UC
- Steel B
- Economy stainless steel type SSUC
- Economy stainless steel type SSSB

### Material

- Housing: Exclusive PBT
- Stainless Steel 304 inserts
- Stainless Steel 304 greaser
- Cover: Polypropylene
- Stainless Steel ring

### Designation example

MUC PPL — Type  
206 — Size  
White — Colour

PPL

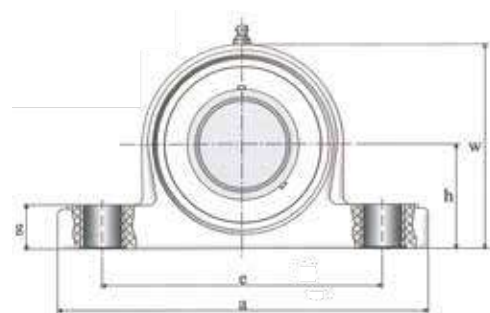
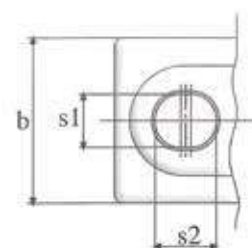
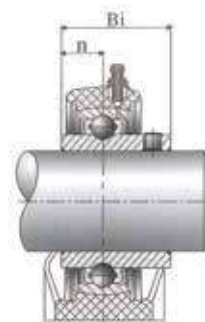

Mode of load	Breaking point test						
	204	205	206	207	208	209	210
	8800	13700	12650	12750	13100	13360	13850
	7700	10000	10600	10800	11100	11400	11750
	5000	8100	5750	7500	8500	8950	9550

Housing number	Shaft diameter mm.	Dimensions (mm)										Weight (Kg.)	max. Torque	
		h	a	e	b	s1	s2	g	w	Bi	n		bolt d.	Nm
PPL204	12	33,3	127	95	38	11	14	14,2	65,5	31	12,7	0,32	M10	18
PPL204	15	33,3	127	95	38	11	14	14,2	65,5	31	12,7	0,31	M10	18
PPL204	17	33,3	127	95	38	11	14	14,2	65,5	31	12,7	0,30	M10	18
PPL204	20	33,3	127	95	38	11	14	14,2	65,5	31	12,7	0,29	M10	18
PPL205	25	36,5	140,5	105	38	11	14	14,5	71	34	14,3	0,34	M10	25
PPL206	30	42,9	163	119	46	14	18	17,8	84	38,1	15,9	0,54	M12	30
PPL207	35	47,6	168	127	48	14	18	18	94,5	42,9	17,5	0,78	M12	35
PPL208	40	49,2	184	137	54	14	18	19,5	99	49,2	19	0,97	M12	45
PPL209	45	54	192	146	54	17	20	23	106	49,2	19	1,09	M16	50
PPL210	50	57,2	206	159	60	17	20	23	114	51,6	19	1,20	M16	55

- Thermoplastic housed pillow blocks.
- Use of back seal cannot be recommended



Designation example  
**MUC NFL** — Type  
**204** — Size  
**White** — Colour

**NFL**

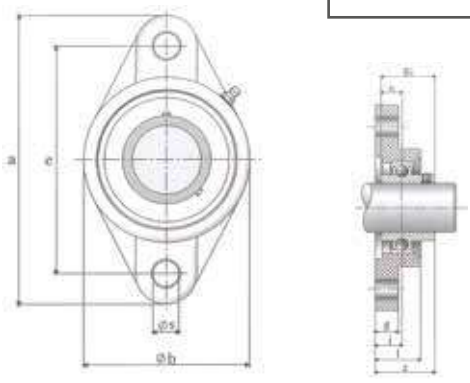

Mode of load	Breaking point test						
	204	205	206	207	208	209	210
	11750	11375	16450	16900	17350	17600	17950
	11000	13850	13350	13950	14050	14300	14550
	8500	11100	14200	14900	14900	15150	15650

Housing number	Shaft diameter	Dimensions (mm)										Weight (Kg.)	max. Torque	
		mm.	a	e	b	g	l	s	z	i	Bi		n	bolt d.
NFL204	12	114	90	65	11,4	26,5	11	33,7	15,4	31	12,7	0,27	M10	18
NFL204	15	114	90	65	11,4	26,5	11	33,7	15,4	31	12,7	0,26	M10	18
NFL204	17	114	90	65	11,4	26,5	11	33,7	15,4	31	12,7	0,25	M10	18
NFL204	20	114	90	65	11,4	26,5	11	33,7	15,4	31	12,7	0,24	M10	18
NFL205	25	131	99	69,5	13,5	29,1	11	36,7	17	34	14,3	0,30	M10	25
NFL206	30	148	117	80	13,3	30,5	11	41,2	19	38,1	15,9	0,45	M10	30
NFL207	35	164	130	90	16,1	32,8	13	43,4	18	42,9	17,5	0,66	M12	35
NFL208	40	176	144	100	20	37,5	14	51,7	21,5	49,2	19	0,87	M12	40
NFL209	45	188,5	148,5	108	21	41	17	54,2	24	49,2	19	1,00	M16	45
NFL210	50	197	157	115	21	43	17	57,6	25	51,6	19	1,20	M16	50

– Thermoplastic housed 2-bolt flange.

**FPL**



Designation example  
**MUC FPL** — Type  
**204** — Size  
**White** — Colour

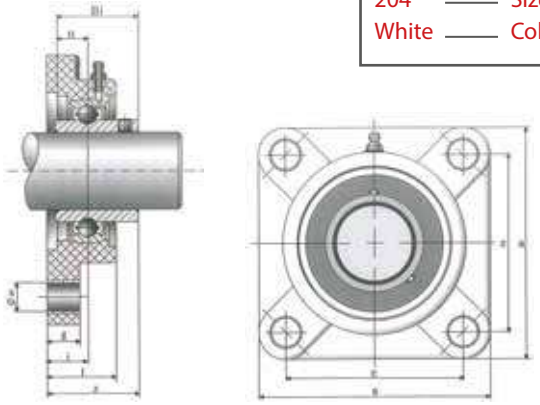

Mode of load	Breaking point test						
	204	205	206	207	208	209	210
	15950	13000	18000	18500	19100	19350	19650
	10250	12150	17700	18500	19250	19350	19620
	3650	3350	3350	3520	3790	3850	3990

Housing number	Shaft diameter	Dimensions (mm)										Weight (Kg.)	max. Torque	
		mm.	a	e	g	l	s	z	i	Bi	n		bolt d.	Nm
FPL204	12	87	63,5	13,4	27,8	11	36,3	18	31	12,7	0,32	M10	18	
FPL204	15	87	63,5	13,4	27,8	11	36,3	18	31	12,7	0,31	M10	18	
FPL204	17	87	63,5	13,4	27,8	11	36,3	18	31	12,7	0,30	M10	18	
FPL204	20	87	63,5	13,4	27,8	11	36,3	18	31	12,7	0,29	M10	18	
FPL205	25	95	70	14,3	28	11	36,7	17	34	14,3	0,36	M10	25	
FPL206	30	107	83	14,3	31,5	11	41,4	19,2	38,1	15,9	0,50	M10	30	
FPL207	35	118	92	15,5	34,8	13	46,9	21,5	42,9	17,5	0,74	M12	35	
FPL208	40	130	102	17	37,5	14	53,2	23	49,2	19	0,97	M12	40	
FPL209	45	137	105	19	41	17	54,2	24	49,2	19	1,10	M16	45	
FPL210	50	143	111	21	43	17	57,2	25	51,6	19	1,25	M16	50	

– Thermoplastic housed square flange.

Thermoplastic bearing units

### Designation example

MUC TBL — Type  
204 — Size  
White — Colour

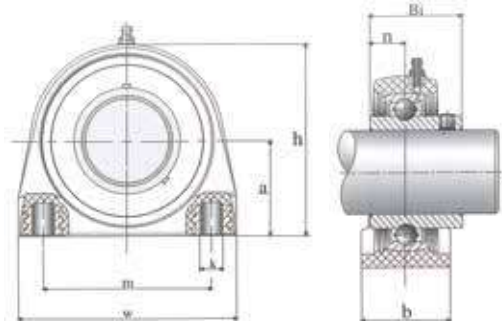

TBL

Mode of load	Breaking point test						
	204	205	206	207	208	209	210
	8210	8540	10370	12150	12230	12900	13850
	6900	7010	6580	8080	9100	10400	11050
	2980	2850	4950	8160	9800	10710	11360

Housing number	Shaft diameter	Dimensions (mm)								Weight (Kg.)	max. Torque	
		mm.	a	b	h	m	w	k	Bi		n	bolt d.
TBL204	12	33,3	34,5	66	50,8	72,8	M8	31	12,7	0,38	M8	18
TBL204	15	33,3	34,5	66	50,8	72,8	M8	31	12,7	0,37	M8	18
TBL204	17	33,3	34,5	66	50,8	72,8	M8	31	12,7	0,36	M8	18
TBL204	20	33,3	34,5	66	50,8	72,8	M8	31	12,7	0,35	M8	18
TBL205	25	36,5	39,5	73,5	50,8	76,2	M10	34	14,3	0,40	M10	25
TBL206	30	42,9	42,5	84	76,2	101	M10	38,1	15,9	0,55	M10	30
TBL207	35	47,6	47,5	95	82,6	110	M10	42,9	17,5	0,80	M10	35
TBL208	40	49,2	48	100,5	88,9	120	M12	49,2	19	0,95	M12	45
TBL209	45	54	50	108,5	95,3	124	M12	49,2	19	1,10	M16	50

- Thermoplastic housed tapped base.
- Back seal not possible

### Designation example

MUC FBL — Type  
204 — Size  
White — Colour

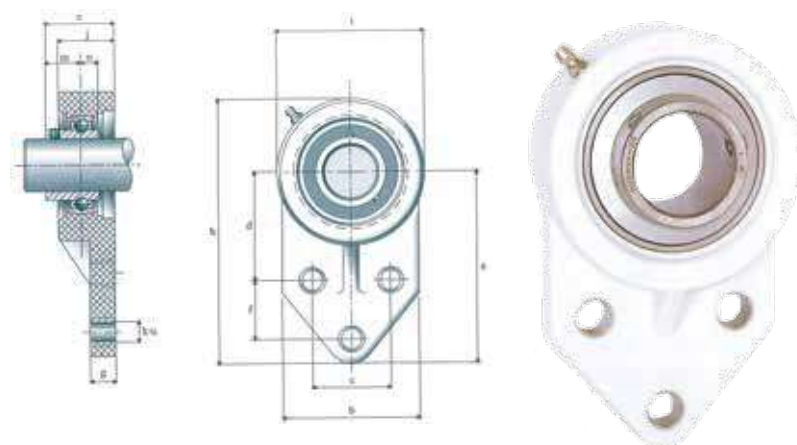

FBL

Mode of load	Breaking point test			
	204	205	206	207
	7200	9100	12200	12900
	9200	11100	11800	11900
	2600	2800	2900	3100

Housing number	Shaft diameter	Dimensions (mm)													Weight (Kg.)	max. Torque	
		mm.	a	b	c	d	e	f	g	h	i	j	k	m		n	bolt d.
FBL204	12	76,2	62	38,1	42,9	33,7	22,2	11,4	108	63,5	26,5	10,7	18,3	12,7	0,28	M10	18
FBL204	15	76,2	62	38,1	42,9	33,7	22,2	11,4	108	63,5	26,5	10,7	18,3	12,7	0,26	M10	18
FBL204	17	76,2	62	38,1	42,9	33,7	22,2	11,4	108	63,5	26,5	10,7	18,3	12,7	0,25	M10	18
FBL204	20	76,2	62	38,1	42,9	33,7	22,2	11,4	108	63,5	26,5	10,7	18,3	12,7	0,25	M10	18
FBL205	25	85,7	63,5	41,3	46	41,2	28,6	11,4	120,6	70	34	10,7	19,7	14,3	0,30	M10	25
FBL206	30	96,5	76	47,6	52,4	41,5	31,8	13,3	138,5	83	32	10,7	22,2	15,9	0,46	M10	30
FBL207	35	109,5	89	50,8	60,3	47,1	31,8	16,1	157	95	36,5	13,1	25,4	17,5	0,66	M12	35

- Thermoplastic housed 3-bolt flange.



**TPL**

**Designation example**

MUCTPL — Type  
204 — Size  
White — Colour

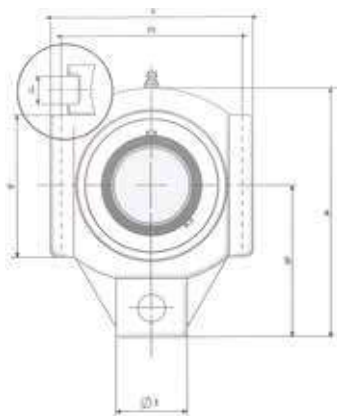

Mode of load	Breaking point test						
	204	205	206	207	208	209	210
	14800	15500	15800	16500	17300	18210	18860
	3930	4530	5100	6500	7800	8710	9750
	8500	10350	10900	11300	12150	12900	13550
	40770	45300	46100	44100	42800	44230	44880

Housing number	Shaft diameter	Dimensions (mm)											Weight (Kg.)
		mm.	a	c	d	h	m	s	t	v	w	Bi	
TPL204	12	99	27,5	12	64	76	M16	36	89	47	31	12,7	0,38
TPL204	15	99	27,5	12	64	76	M16	36	89	47	31	12,7	0,37
TPL204	17	99	27,5	12	64	76	M16	36	89	47	31	12,7	0,36
TPL204	20	99	27,5	12	64	76	M16	36	89	47	31	12,7	0,35
TPL205	25	99	27,5	12	64	76	M16	36	89	47	34	14,3	0,40
TPL206	30	125	34,5	12	76	89	M16	40	102,5	63	38,1	15,9	0,55
TPL207	35	125	34,5	12	76	89	M16	40	102,5	63	42,9	17,5	0,80
TPL208	40	140	34,5	16	85	102	M16	40	113	80	49,2	19	0,95
TPL209	45	149	40	16	90	102	M20	50	117	85	49,2	19	1,10
*TPL210	50	149	40	16	90	102	M20	50	117	85	51,6	19	1,25



- Thermoplastic housed take-up unit.
- Back seal not possible
- \* Only available in black, not ANB brand

**HPL**

**Designation example**

MUCHPL — Type  
204 — Size  
White — Colour

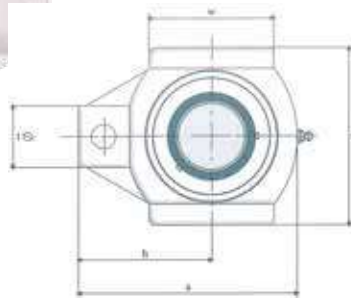

Mode of load	Breaking point test						
	204	205	206	207	208	209	210
	14800	15500	15800	16500	17300	18210	18860
	3930	4530	5100	6500	7800	8710	9750
	8500	10350	10900	11300	12150	12900	13550
	40770	45300	46100	44100	42800	44230	44880

Housing number	Shaft diameter	Dimensions (mm)										Weight (Kg.)
		mm.	a	c	h	m	s	t	w	Bi	n	
HPL204	12	99	27,5	63,5	65	M16	36	47	31	12,7	0,38	
HPL204	15	99	27,5	63,5	65	M16	36	47	31	12,7	0,37	
HPL204	17	99	27,5	63,5	65	M16	36	47	31	12,7	0,36	
HPL204	20	99	27,5	63,5	65	M16	36	47	31	12,7	0,35	
HPL205	25	99	27,5	63,5	74	M16	36	47	34	14,3	0,40	
HPL206	30	125	34,5	76	90	M16	40	63	38,1	15,9	0,55	
HPL207	35	125	34,5	76	90	M16	40	63	42,9	17,5	0,80	
HPL208	40	140	34,5	85	100	M16	40	80	49,2	19	0,90	
HPL209	45	149	40	90	110	M20	50	85	49,2	19	1,10	
HPL210	50	149	40	90	110	M20	50	85	51,6	19	1,20	

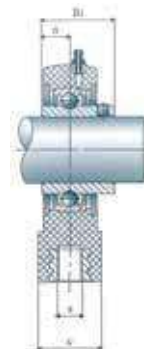

- Thermoplastic housed hanger unit.
- Back not possible

Thermoplastic bearing units

### Designation example

MB CTL — Type  
204 — Size  
White — Colour



CTL

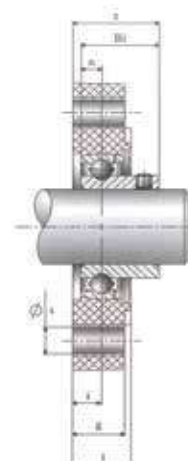
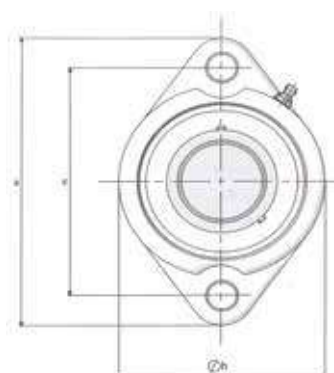

Mode of load	Breaking point test				
	204	205	206	207	208
	9900	10100	14000	14300	14700
	9300	11700	11300	11800	11900
	7200	9400	12000	12600	12800

Housing number	Shaft diameter	Dimensions (mm)										Weight (Kg.)	max. Torque	
		mm.	a	e	b	g	l	s	z	Bi	n		i	bolt d.
CTL204	20	90,5	71,4	66,5	18,4	20	9	27	24,7	7	9,5	0,17	M8	15
CTL205	25	97	76,2	71	18,4	21,2	9	29,5	27	7,5	10,0	0,22	M8	15
CTL206	30	112,5	90,5	84	20,5	23,3	11	33,5	30,3	8	11,5	0,34	M10	20
*CTL207	35	126	100	94	22,5	25,3	11	36,5	32,9	8,5	12,5	0,49	M10	25
*CTL208	40	150	119	100	24	26,8	14	39,5	35,5	9	13,5	0,62	M12	30

- Thermoplastic housed 2 bolt range.
- Back seal not possible.
- \* Only available in white

Unit number	Shaft diameter	Dimensions (mm)										Weight (Kg.)	max. Torque	
		mm.	a	e	b	g	l	s	z	Bi	n		i	bolt d.
LNFL201	12	100	76,5	56	11,4	26	10,7	31,4	26	10	0,24	M10	16	
LNFL202	15	100	76,5	56	11,4	26	10,7	31,4	26	10	0,23	M10	16	
LNFL203	17	100	76,5	56	11,4	26	10,7	31,4	26	10	0,22	M10	16	
LNFL204	20	100	76,5	56	11,4	26	10,7	31,4	24,7	10	0,22	M10	16	

LNFL 200

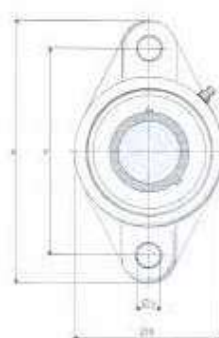



**L-FPL**

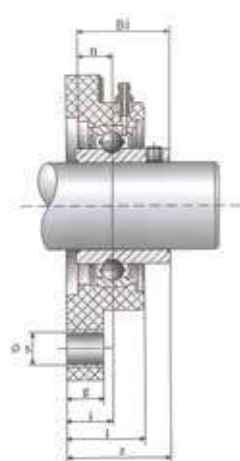

Designation example  
 MUC L-FPL — Type  
 203 — Size  
 White — Colour

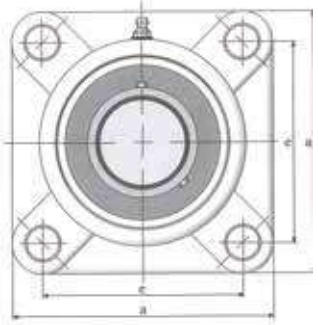

Mode of load	Breaking point test	
	201-203	
	14500	
	9250	
	3550	

Housing number	Shaft diameter	Dimensions (mm)									Weight (Kg.)	max. Torque	
		mm.	a	e	g	l	s	z	i	Bi		n	bolt d.
L-FPL203	12	77	54	13,3	28	10,7	33	17	26	10	0,24	M10	16
L-FPL203	15	77	54	13,3	28	10,7	33	17	26	10	0,23	M10	16
L-FPL203	17	77	54	13,3	28	10,7	33	17	26	10	0,22	M10	16

- Thermoplastic housed light 4-hole flange
- Only available in white

**LXL**

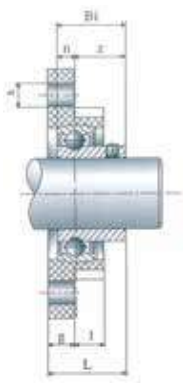

Designation example  
 MB/MUC  
 Mini LXL — Type  
 203 — Size  
 White — Colour

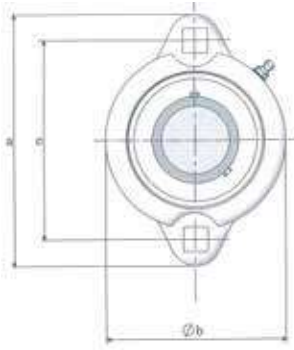

Mode of load	Breaking point test				
	203	204	205	206	207
	8000	8400	8800	11500	11800
	7800	8500	9200	10900	11600
	5200	6300	8600	10300	10500

Housing number	Shaft diameter	Dimensions (mm)										bolt size (mm)	Weight (Kg.)
		mm.	a	c	h	m	s	t	w	Bi	L		
MUC Mini LXL203	12	81	64	10	8	7	56	16	22	28,6	6	M6	0,26
MUC Mini LXL203	15	81	64	10	8	7	56	16	22	28,6	6	M6	0,26
MUC Mini LXL203	17	81	64	10	8	7	56	16	22	28,6	6	M6	0,24
MBLXL204	20	90	71	11	9	9	63	17,5	24,7	31	7	M8	0,28

- Thermoplastic housed 2-hole flange.
- Not flat on the back.
- Back seal and caps not possible.
- Only available in white

Thermoplastic bearing units

# Thermoplastic bearing units

### Designation example

MB/MUCmini LFL- Type  
203 — Size  
White — Colour

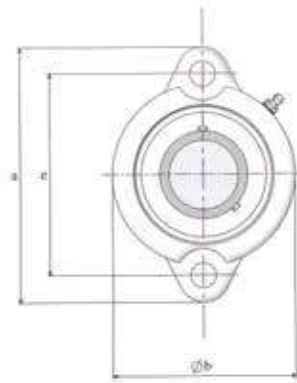

LFL

Mode of load	Breaking point test				
	203	204	205	206	207
	8000	8400	8800	11500	11800
	7800	8500	9200	10900	11600
	5200	6300	8600	10300	10500

Housing number	Shaft diameter	Dimensions (mm)										bolt size	Weight
	mm.	a	e	g	l	s	b	z	Bi	L	n	(mm)	(Kg.)
MUC201 mini LFL203	12	81	64	10	8	7	56	16	22	28,6	6	M6	0,26
MUC202 mini LFL203	15	81	64	10	8	7	56	16	22	28,6	6	M6	0,25
MUC203 mini LFL203	17	81	64	10	8	7	56	16	22	28,6	6	M6	0,24
MBLFL204	20	90	71	11	9	10	63	17,5	24,7	31	7	M8	0,28
MBLFL205	25	95	76	11	10	10	69	19,5	27	31	7,5	M8	0,36

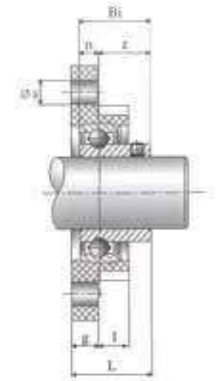

- Thermoplastic housed 2-hole flange.
- Back seal and caps not possible.
- Only available in white

# Covers - Thermoplastic units

Caps available in white, black and green



Dimensions /Material

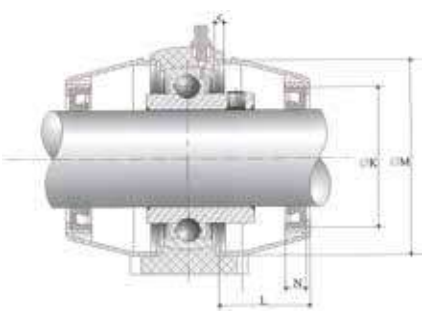

Shaft diameter	Dimensions (mm)						
	mm.	K	N	L	M	D	b
12	28	7	22	45	46	6	2,5
15	28	7	22	45	46	6	2,5
17	28	7	22	45	46	6	2,5
20	32	7	23	50	52	6	3
25	37	7	25	55	62	6	4
30	42	7	30	64	72	6	4
35	47	7	32	74,5	82	6	4,5
40	52	7	37	84	88	6	3,5
45	57	7	41	89	93	6	4,5
50	62	7	47	94	98	6	5

Physical properties

Properties	Unit	Test method	Value
Density	G/cm <sup>3</sup>	DIN 53479	1,53
Water absorption (23 <sup>o</sup> )	%	DIN 53495	0,5
Mould Shrinkage	%	-	0,4
Moisture absorption (23 <sup>o</sup> )	%	DIN 53714	0,2

Mechanical properties

Properties	Unit	Test method	Value
Tensile yield strength	MPa	ASTM-D638	12
Elongation at break	%	ASTM-D638	1125
Flexural strength	MPa	ASTM-D790	29
Notched izod impact	J/m	ASTM-D256	12

Thermal properties

Properties	Unit	Test method	Value
HDT at load 1,8 Mpa	°C	DIN 53461	210
HDT at load 0,45 MPa	°C	DIN 53461	220
Melting point	°C	-	225
UL Flammability (thickness)	°C	UL 94	HB
Max. Temp in glow wire test	°C	IEC 695/2/1	
2 mm. thickness			750
4 mm. thickness			960

Electrical properties

Properties	Unit	Test method	Value
Dielectric constant at 1 MHz	-	IEC 250	3,8
Dielectric	Kv/mm.	VDE 0303/2	34
Volume resistivity	Ohm x cm.	VDE 0303/2	>10 <sup>15</sup>
Surface resistivity	ohm	VDE 0303/2	>10 <sup>15</sup>

Dimensions / Material





Back Seals

### Back Seals

Back seal eliminates the down-time associated with particles that invade bearing components and ultimately cause failure.

Back Seal eliminates the down-time associated with peeling, chipping and flaking of the housing.

They can only be used with B steel insert, Special MB Stainless Steel inserts or SS SB.

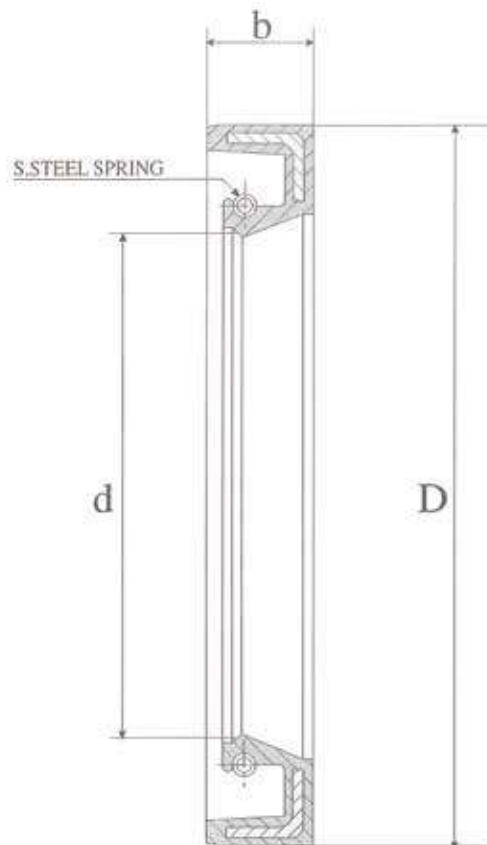

Size	Dimensions (mm)		
	d	b	D
202	15	6	46
203	17	6	46
204	20	6	52
205	25	6	62
206	30	6	72
207	35	6	82
208	40	6	88
209	45	6	93
210	50	6	98



**Technical data**

Our 100% Stainless Steel units are manufactured from a select grade of Stainless Steel which has been carefully chosen to give you what you have asked for: optimal corrosion resistance. Bearing life is excellent because it is not limited to the life of the coating and/or nickel plating.

Material	Unit MUC200
Ring and Balls	SUS440C
Slinger and Retainer	SUS304
Seal	Nitril rubber (NBR)
Set screw	SUS304
Housing	SCS13

**Operating temperatures range**

-20~+120c.

Scratches and marks have absolutely no effect on the bearings ability to resist rust and corrosion.

Excellent for use in food processing, beverage and other high-corrosive applications, these bearings are 100% stainless throughout: housing, balls, inner and outer races, cages, slingers and set screws.

Tolerance for SS bearing inner rings								
Nominal Bore DIA (mm.)		Bore diameter				Width		Radial run-out
		dm. Deviations		d Deviations		B Deviations		
over	incl.	high	low	high	low	high	low	max.
18	30	+21	0	+25	-4	0	-120	18
30	50	+25	0	+30	-5	0	-120	20

SP

**Designation example**  
 SP — Housing type  
 SSUC — Bearing type  
 204 — Size

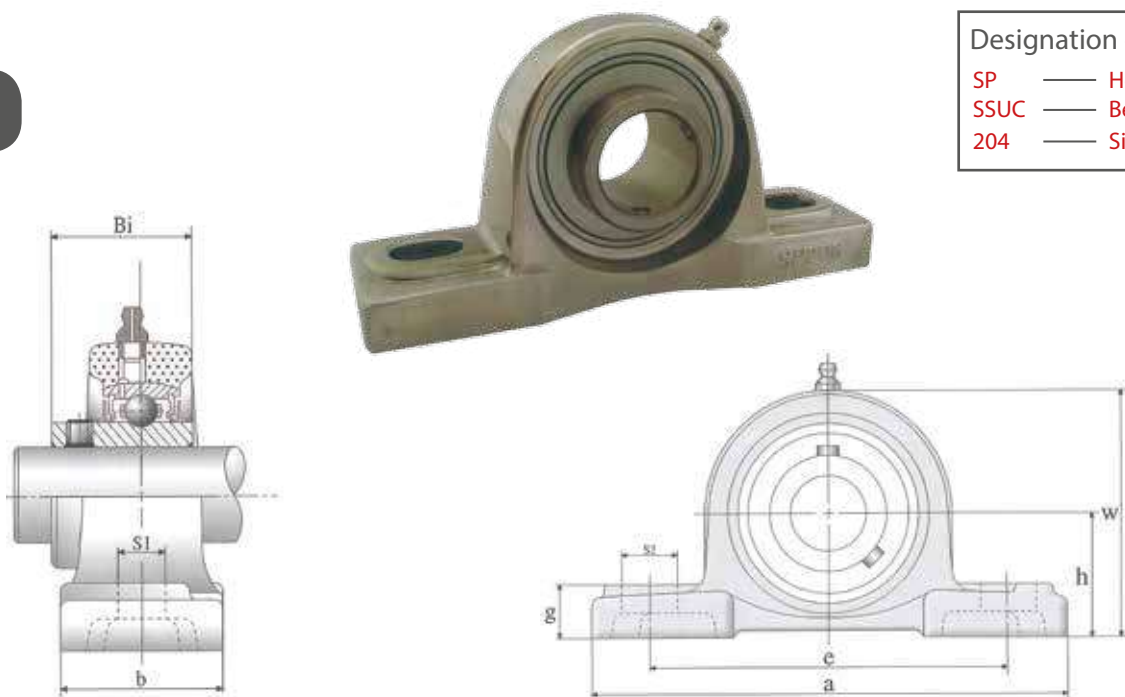

Housing number	Shaft diameter	Dimensions (mm)										Weight (Kg.)
	mm.	Da	h	a	e	b	S1	S2	g	w	Bi	
SP204	20	47	33,3	126	95	38	12,8	18,9	15,1	65,1	31	0,9
SP205	25	52	36,5	140	105	38	13,1	19,1	16	70	34,1	0,95
SP206	30	62	42,9	165	121	48	17	21,3	18	83	38,1	1,6
SP207	35	72	47,6	167	127	48	14,2	22	19	94	42,9	1,9
SP208	40	80	49,2	184	136,5	54	16,8	23	19	100	49,2	2,4
SP209	45	85	54,0	190	146	54	16,8	20,8	20	109	49,2	2,7
SP210	50	90	57,2	206	159	60	19,9	25	22	114	51,6	3,1

- Stainless Steel pillow blocks.  
 - Caps + back seal not available

Designation example  
**SF** — Housing type  
**SSUC** — Bearing type  
**204** — Size

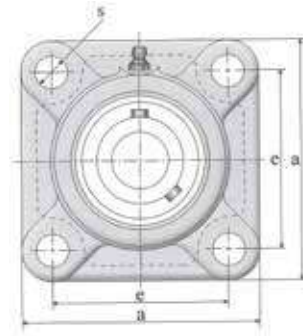

SF

Housing number	Shaft diameter mm.	Dimensions (mm)								Weight (Kg.)
		Da	a	e	i	l	g	s	Bi	
SF204	20	47	86	63,5	15,1	25,4	12	11	33,4	0,63
SF205	25	52	95	70	15,9	27	14	12	35,7	0,85
SF206	30	62	108	82,5	17,9	30	14	12	40,1	1,17
SF207	35	72	117,5	92	19,1	33	14,3	14	44,5	1,51
SF208	40	80	130	101,6	21	36	14,3	16	51,2	2
SF209	45	85	137	104,8	21,8	38	14,3	16	52	2,2
SF210	50	90	143	111	21,8	39	15,1	16	54,4	2,4

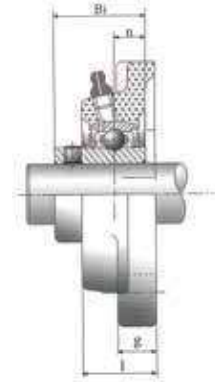

- Stainless Steel 4-hole flange.
- Caps + back seal not available

Designation example  
**SFL** — Housing type  
**SSUC** — Bearing type  
**204** — Size

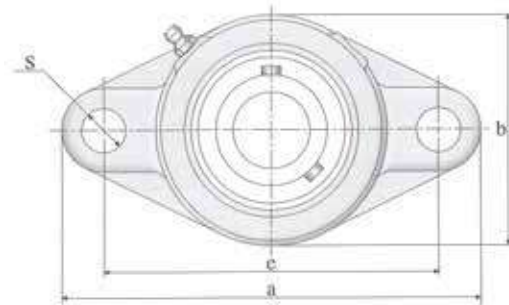

SFL

Housing number	Shaft diameter mm.	Dimensions (mm)									Weight (Kg.)
		Da	a	e	i	b	l	g	s	Bi	
SFL204	20	47	112	90	15.1	60	25.4	11.5	12	31	0.5
SFL205	25	52	125	99	15.9	68	27	13	16	34.1	0.65
SFL206	30	62	141	117	17.9	80	30	13	16	38.1	0.9
SFL207	35	72	155.5	130	19.1	90	33	14.3	16	42.9	1.2
SFL208	40	80	171.5	144	21	100	36	14.3	16	49.2	1.6
SFL209	45	85	179	148	21.8	108	37	14.3	19	49.2	1.8
SFL210	50	90	189	157	21.8	115	38	15.1	19	51.6	2.1

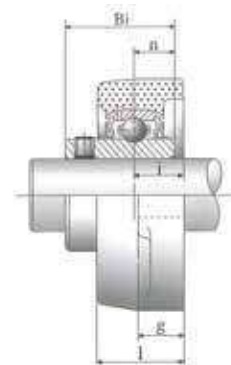

- Stainless Steel 2-hole flange.
- Caps + back seal not available



MUC

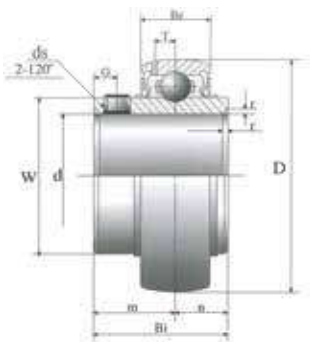

Designation example  
**MUC** — ANB insert  
**206** — Size

Housing number	Shaft diameter mm.	Dimensions (mm)										Weight (Kg.)	Basic load rating (n)	
		D	Bi	Be	r	n	m	G	ds	T	W		Dynamic Cr mm.	Static Cor
MUC201	12	47	31	17	1	12,7	18,3	4,5	M6X0,75	4,5	29	0,21	10900	5300
MUC202	15	47	31	17	1	12,7	18,3	4,5	M6X0,75	4,5	29	0,19	10900	5300
MUC203	17	47	31	17	1	12,7	18,3	4,5	M6X0,75	4,5	29	0,18	10900	5300
MUC204	20	47	31	17	1	12,7	18,3	4,5	M6X0,75	4,5	29	0,15	10900	5300
MUC205	25	52	34	17	1,5	14,3	19,8	8	M6X0,75	4,5	34	0,19	11900	6300
MUC206	30	62	38,1	19	1,5	15,9	22,2	5	M6X0,75	5,1	40,5	0,31	16700	9050
MUC207	35	72	42,9	20	2	17,5	25,4	6	M8X1	5,8	48	0,48	22000	12300
MUC208	40	80	49,2	21	2	19	30,2	8	M8X1	6,2	53	0,62	24900	14300
MUC209	45	85	49,2	22	2	19	30,2	8	M8X1	6,5	57,3	0,67	28100	16400
MUC210	50	90	51,6	23	2	19	32,6	9	M810X1,25	6,5	63	0,78	30200	18600

Alternative: stainless steel bearing SS UC available (Chinese version)

MB

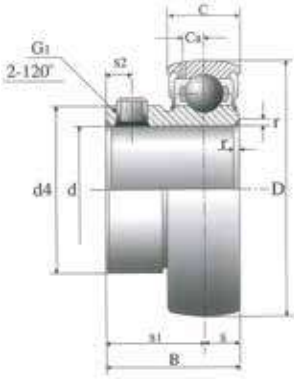

Designation example  
**MB** — ANB insert  
**204** — Size

Housing number	Shaft diameter mm.	Dimensions (mm)											Weight (Kg.)	Basic load rating (n)	
		d	D	B	C	r	s	s1	s2	G1	Ca	d4		Dynamic Cr mm.	Static Cor
MB204	20	20	47	25	14	1,5	7	18	4	M6X0,75	4	28,3	0,125	10900	5300
MB205	25	25	52	27	15	1,5	7,5	19,5	4,2	M6X0,75	4,2	34	0,160	11900	6300
MB206	30	30	62	30	16	1,5	8	22	5	M6X0,75	5	40,3	0,250	16700	9000
MB207	35	35	72	32	17	2	8,5	23,5	5,6	M8X1	5,6	46,9	0,380	22000	12300
MB208	40	40	80	34	18	2	9	25	6	M8X1	6	52,4	0,490	24900	14300
MB209	45	45	85	41,2	19	2	10,2	31,7	6,3	M8X1	6,3	57,4	0,56	26000	16300
MB210	50	50	90	43,5	20	2	10,9	33,5	8	M8X1	6,6	61,8	0,62	28000	18000

Special for use with back seal.

Alternative: stainless steel bearing SS SB available (Chinese version)

Stainless Steel bearing insert

Designation example

UC — ANB insert  
208 — Size

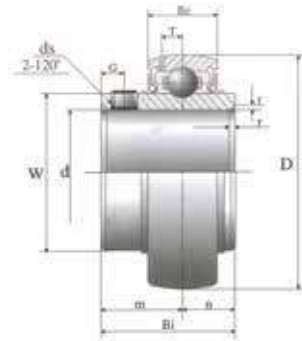

UC

Housing number	Shaft diameter	Dimensions (mm)										Weight (Kg.)	Basic load rating (n)	
		D	Bi	Be	r	n	m	G	ds	T	W		Dynamic Cr	Static Cor
													mm.	mm.
UC204	20	47	31	17	1	12,7	18,3	4,5	M6X0,75	4,5	29	0,16	12850	6670
UC205	25	52	34	17	1,5	14,3	19,8	5	M6X0,75	4,5	34	0,19	14028	7848
UC206	30	62	38,1	19	1,5	15,9	22,2	5	M6X0,75	5,1	40,5	0,30	19620	11280
UC207	35	72	42,9	20	2	17,5	25,4	6	M8X1	5,8	48	0,48	25898	15400
UC208	40	80	49,2	21	2	19	30,2	8	M8X1	6,2	53	0,62	29330	17950
UC209	45	85	49,2	22	2	19	30,2	8	M8X1	6,5	57,3	0,67	32860	20500
UC210	50	90	51,6	23	2	19	32,6	9	M810X1,25	6,5	63	0,78	35315	23249

Alternative: steel bearing B (flat on the back)

## Plastic insert - under water units

- No maintenance
- Chemical resistant
- Easily cleaned smooth surface

Material

- PNS: Delrin
- UC200P: Acetal and 316
- Stainless Steel balls



Plastic Insert

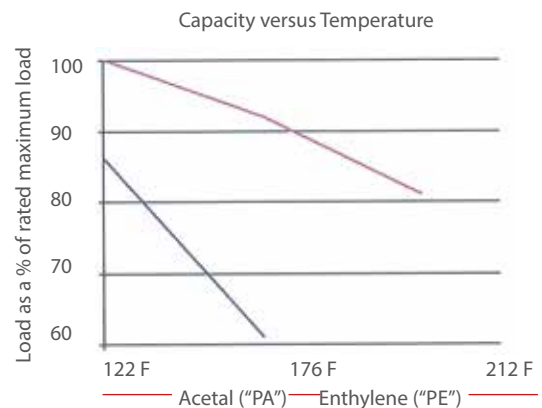
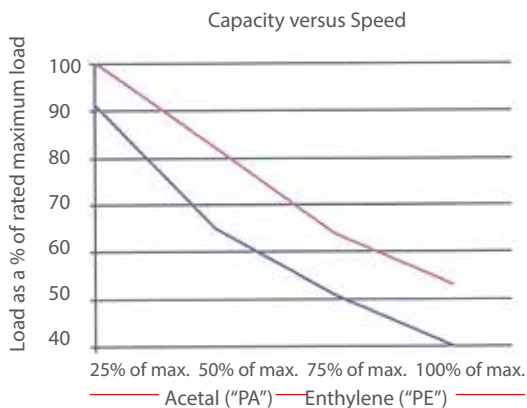

Steel bearing insert/  
Plastic insert

UCP

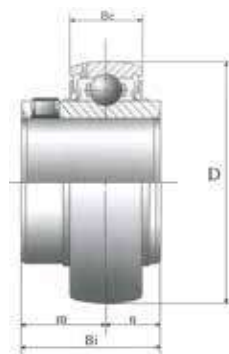

Housing number	d	D	Bi	Be	m	n	Load capacity single row (N)		max. speed single row
	mm.	mm.	mm.	mm.	mm.	mm.	stat.	dyn	rpm
UC204P	20	47	31,0	17	18,3	12,7	270	420	1050
UC205P	25	52	34,1	17	19,6	14,5	320	480	950
UC206P	30	68	38,1	19	22,2	15,9	360	550	800

PNS

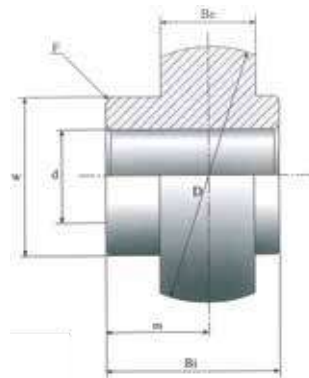

Housing number	Dimensions (mm)							
	d	tol.	D	Bi	m	Be	w	F
PNS204	20		47	31	18,3	17	29	1,5
PNS205	25	+0,04	52	34	19,7	17	34	1,5
PNS206	30	+0,08	62	38,1	22,2	19	40,5	1,5
PNS207	35	+0,05	72	42,9	25,4	20	48	1,5
PNS208	40	+0,10	80	49,2	30,2	21	53	1,5
PNS209	45	+0,06	85	49,2	30,2	22	57,3	1,5
PNS210	50	+0,12	90	51,6	32,6	23	63	1,5

Plastic bearing insert

An obvious complimentary product to conveyor building is the side guard brackets, return rollers, hinges, photo-cell holders and clamps etc.

We offer a wide range of products from stock in reinforced polyamide quality, for effective, time- and cost- saving, design related tasks. All the components are made from the philosophy that they should be Easy-To-Use and Easy-To-Clean.

***Apart from the numerous standard wear profiles found in the following pages, we also offer to produce special curves, tracks or wear parts from our own workshop.***







Reinforced polyamide, bushings in nickel plated brass.

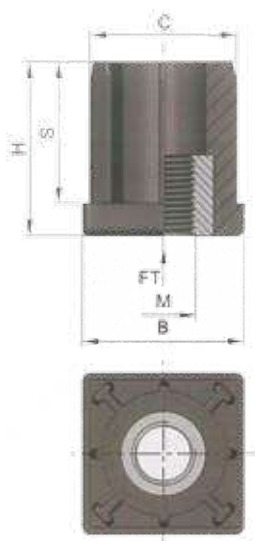

TUBE ENDS

FT: Max. static load.

M	B	C	H	S	Square tubes			FT N (Newton)	Kg	COD.
					EXT.	INT.	Thickness			
8	25	22,5	30	25	25	22	1,5	5000	0,04	1482201
10									0,04	1482205
12									0,04	1482209
10	30	27,5	33	27	30	27	1,5	5500	0,04	1482211
12									0,04	1482212
14									0,04	1482213
16									0,04	1482214
10	30	26,5	33	27	30	26	2	5500	0,04	1482215
12									0,04	1482216
14									0,04	1482217
16									0,04	1482218
10	35	32,5	43	35	35	32	1,5	5500	0,04	1482221
12									0,04	1482222
14									0,04	1482223
16									0,04	1482224
20									0,04	1482225
10	38	35,4	43	35	38,1	34,9	1,6	6000	0,05	1482230
12									0,05	1482231
14									0,05	1482232
16									0,05	1482233
20	40	37,5	43	35	40	37	1,5	6000	0,05	1482234
10									0,05	1482240
12									0,05	1482241
14									0,06	1482242
16									0,06	1482243
20	40	36,5	43	35	40	36	2	6000	0,06	1482244
10									0,06	1482247
12									0,06	1482248
14									0,06	1482249
16									0,06	1482250
20	50	47,5	55	44	50	47	1,5	10000	0,06	1482251
12									0,10	1482254
14									0,10	1482255
16									0,10	1482256
20	50	46,5	55	44	50	46	2	10000	0,10	1482257
12									0,10	1482265
14									0,10	1482266
16									0,10	1482267
20	50	45,5	55	44	50	45	2,5	10000	0,10	1482268
12									0,10	1482269
14									0,10	1482309
16									0,10	1482311
20	60	56,5	55	45	60	56	2	12000	0,10	1482314
14									0,10	1482318
16									0,14	1482270
20	0,14	1482271								
20									0,14	1482272

Threated tube ends





**Support heads**

**SUPPORT HEADS**

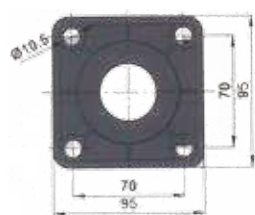
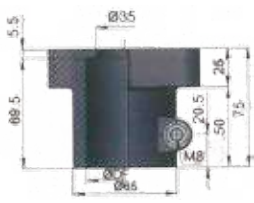

Reinforced polyamide + fastener in stainless steel.

DF		FT N (Newton)	Kg	COD.
mm	inch			
48,3	1 1/2	1500	0,30	8330112
50,9	-		0,30	8330114

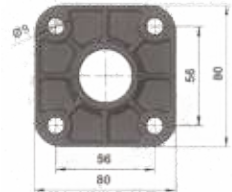

FT N (Newton)	Kg	COD.
1200	0,17	8330082

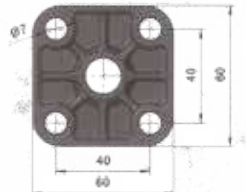
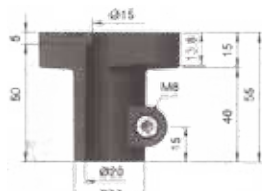

FT N (Newton)	Kg	COD.
800	0,07	8330071

**SPLIT COLLARS**

**Split collars**

Reinforced polyamide + fastener in stainless steel.

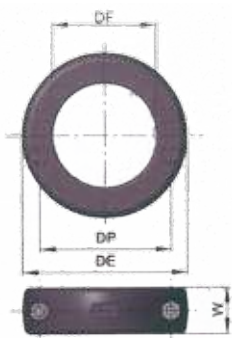

DF	DE	DP	W	Kg	COD.
10	30	20	12	0,01	8235324
12	30	20	12	0,01	8235325
14	30	20	12	0,01	8235327
15	39	27	14	0,02	8235329
16	39	27	14	0,02	8235331
18	39	27	14	0,02	8235334
20	40	29	14	0,02	8235350
25	45	35	14	0,02	8235351
30	55	45	16	0,03	8235352
35	60	47	16	0,03	8235353
40	64	51	18	0,04	8235354



Support heads  
Split collars

Reinforced polyamide, bush in nickel plated brass.

M	Kg	COD.
M8	0,03	1485470
M10		1485495

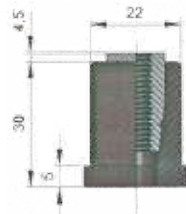

Reinforced polyamide, fastener in stainless steel.

Kg	COD.
0,03	1485540

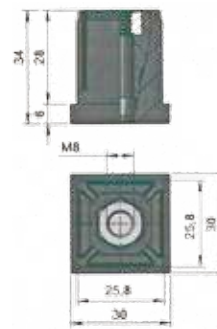

M	Kg	COD.
M8	0,02	1486505
M10		1486526

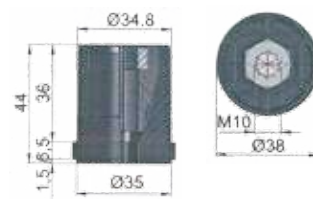

Kg	COD.
0,06	1486571



Reinforced polyamide, fastener in stainless steel.

DE1	DE2	Kg	COD.
38	38	0,07	1486620
	48	0,08	1486625
	60	0,09	1485536



Reinforced polyamide, fastener in stainless steel.

Kg	COD.
0,28	7645301

Incrementos de 15° / Increments of 15°  
Accroissement de 15° / Anstiegen bei 15°

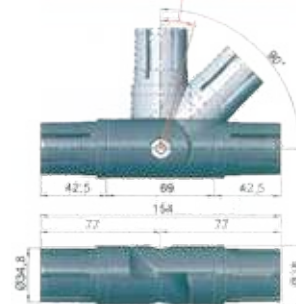

## Return profile support

Self-lubricating polyethylene

Kg	COD.
0,04	8025601

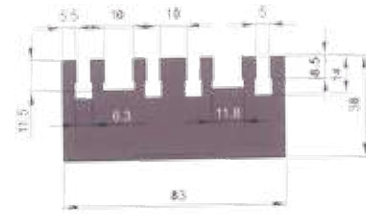

Kg	COD.
0,04	8025630

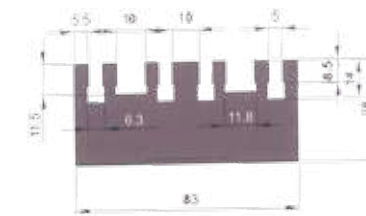

**RETURN PROFILE SUPPORT**

UHMW 1000 "DESLIDUR" Polyethylene.

Colour	L	Kg/m	COD.
Green	25	0,10	P20240



Self-lubricating polyethylene.

Kg	COD.
0,04	8025615

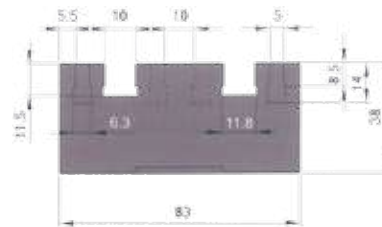

Kg	COD.
0,04	8025621

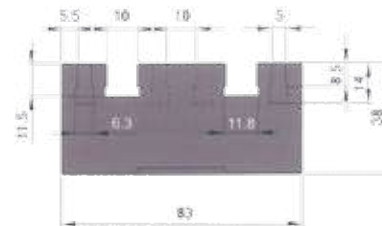

**RETURN Accessories**

*Return accessories*

Self-lubricating polyethylene.

Kg	COD.
0,01	8025645

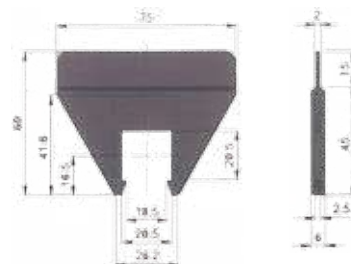

Kg	COD.
0,01	8025650

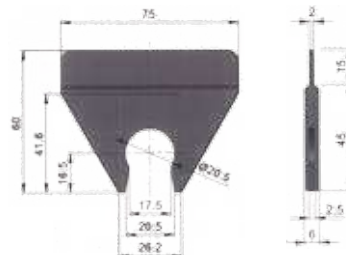

**RETURN COMPONENTS**

*Chain return components*

Self-lubricating polyethylene.

Kg	COD.
0,12	8025104

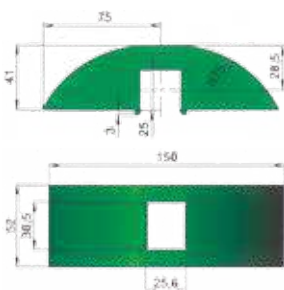

Self-lubricating polyethylene.

Kg	COD.
0,07	8025105

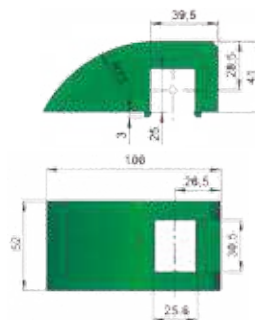

Return profile support, Return accessories, Chain return components.

# Chain return components

Self-lubricating polyethylene.

Kg	COD.
0,09	8025101

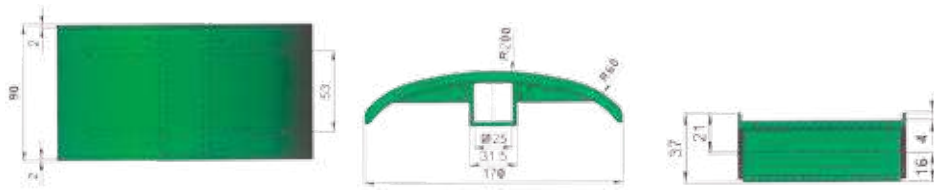

**DOUBLE  
SLIDING**

Kg	COD.
0,15	8025140



**OSCILLATING  
SLIDING SHOE**

Colour	Kg/m	COD.
Green	0,14	8025102V
Black		8025102N

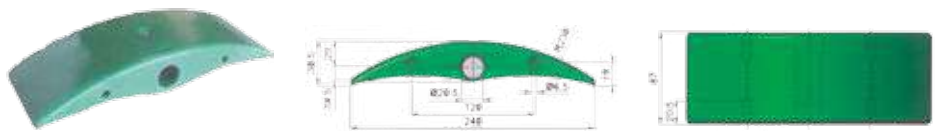

**CLIP-ON  
OSCILLATING  
SLIDING SHOE**

Kg	COD.
0,13	8025103



## Return rollers

**RETURN  
ROLLERS**

Self-lubricating polyamide.

DF	Kg	COD.
12,2	0,03	8010024
16,2	0,03	8010026
18,2	0,03	8010027
20,2	0,03	8010028

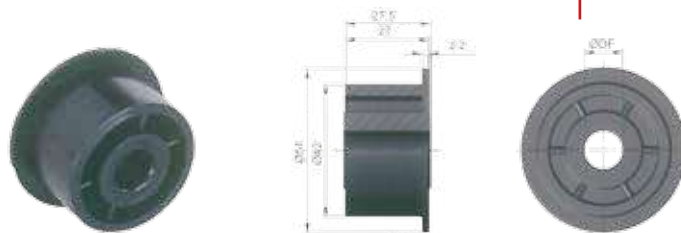

DF	Kg	COD.
12,2	0,03	8010235
16,2	0,03	8010237
18,2	0,03	8010238
20,2	0,03	8010239

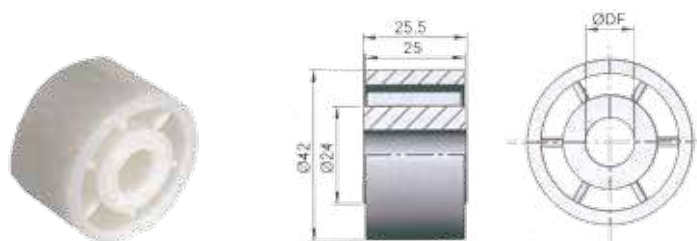

DF	Kg	COD.
12,2	0,03	8010201
16,2	0,03	8010202
18,2	0,03	8010203
20,2	0,03	8010204

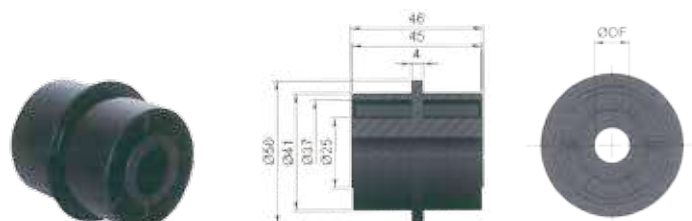

Chain return componer  
Return rollers

Self-lubricating polyamide.

**ROLLERS**

DF	Kg	COD.
12,2	0,03	8010211
16,2	0,03	8010212
18,2	0,03	8010214
20,2	0,03	8010215



D1	DF	Kg	COD.
18	12,2	0,05	8010230
24,2	20,2	0,05	8010241

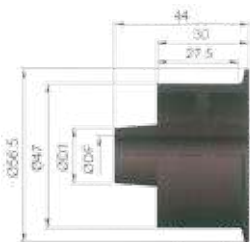

D1	DF	Kg	COD.
18	12,2	0,05	8010234
24,2	20,2	0,05	8010231

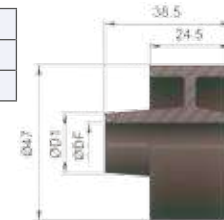

DF	Kg	COD.
20,2	0,06	8010232

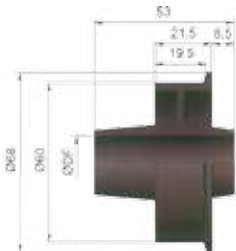

DF	Kg	COD.
20,2	0,06	8010233

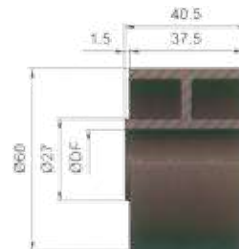

DF	Kg	COD.
20,2	0,06	8010236

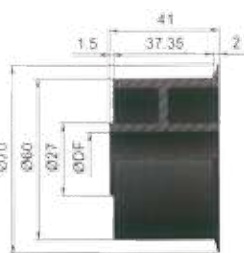

DF	Kg	COD.
12,2	0,07	8010271

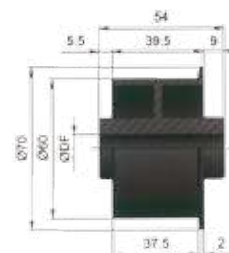

DF	W	Kg	COD.
12,2	31	0,01	8010114
16,2		0,01	8010115
18,2		0,01	8010116
20,2		0,01	8010117
12,2	39	0,01	8010106
16,2		0,01	8010107
18,2		0,01	8010108
20,2		0,01	8010109

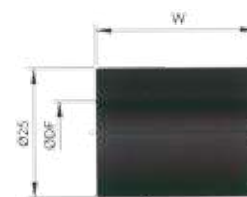

**Rollers**

Self-lubricating polyethylene.

DE	DF	Kg	COD.
40	20,2	0,04	8010315
60	20,2	0,06	8010340

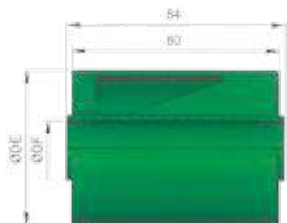

Self-lubricating polyethylene.

DE	DF	Kg	COD.
70	20,2	0,01	8015250

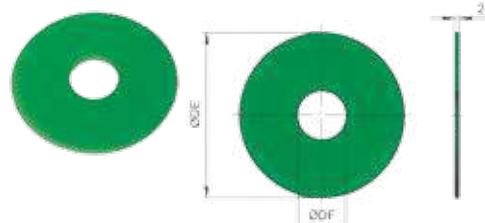





Stainless steel.

**PLIERS**

Kg	COD.
0,50	8427160

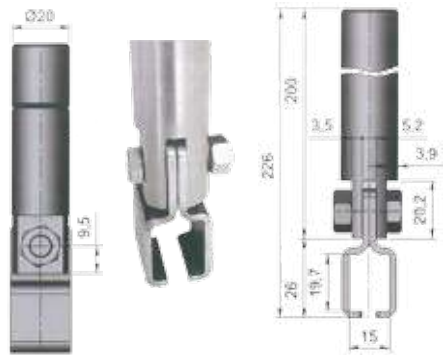

Kg	COD.
0,04	8427165



**TRANSFER MODULE**

Self-lubricating acetal, fasteners in stainless steel.

Kg	COD.
0,05	8429412

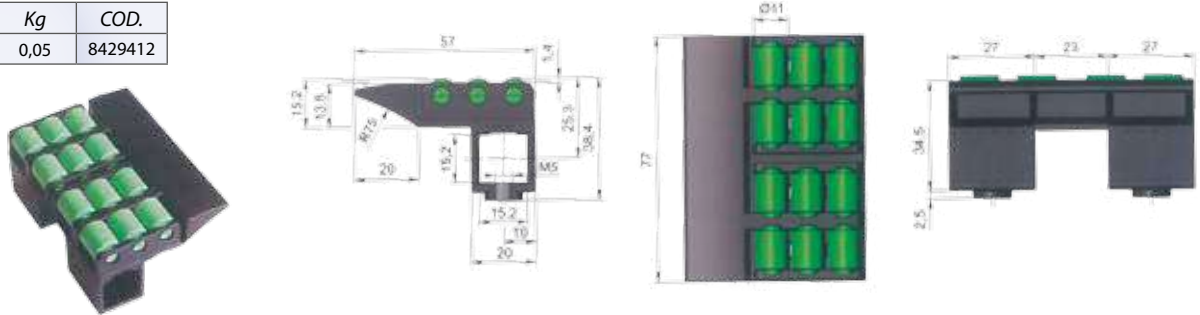

**TRANSFER JUNCTION**

Reinforced polyamide, fasteners in stainless steel.

Kg	COD.
0,03	8429480

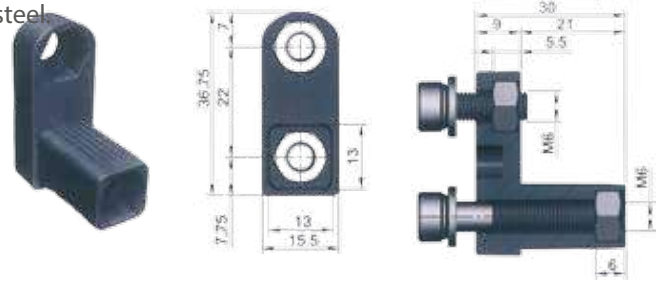

**ROLLER GUIDES**

**Roller guides**

Stainless steel.

DE	LT	Kg	COD.
12	10	104	0,11 8220801
14	12	104	0,14 8220505
15	12	104	0,16 8220811
16	14	104	0,18 8220819

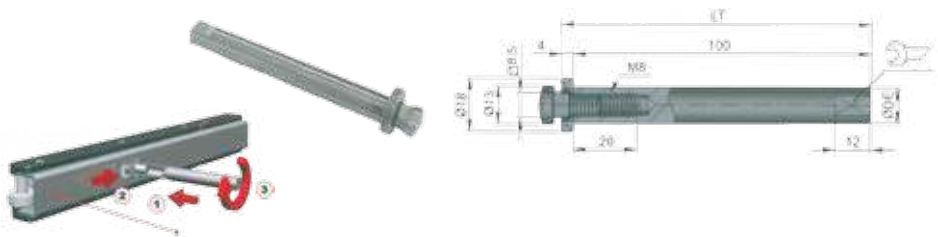

1pc = 1 spindle + 1 screw + 1 washer

Transfers, Roller guides

Structure and pin in stainless steel, roller in acetal.

L	Kg	COD.
1000	2,41	8411652
2000	5,80	8412790
3000	8,22	8413877

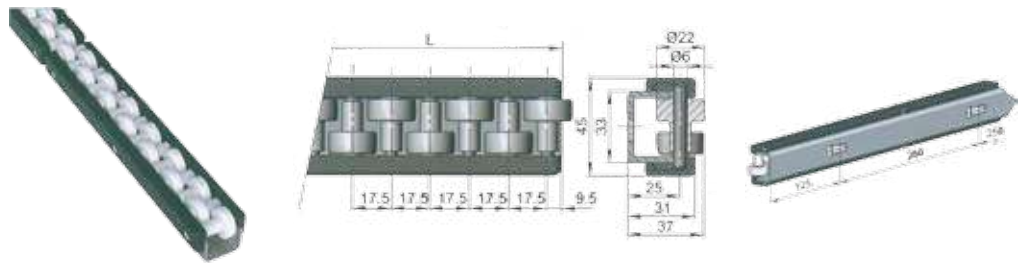





STANDARD  
BRACKETS

Reinforced polyamide, fastener in stainless steel



DF	LA	FT N (newton)	FM N (newton)	Kg	COD.
12,5	9	2000	5000	0,280	8110024
14,5		3000		0,278	8110025
16,5		3200		0,276	8110026
12,5	10,5	2000	5000	0,280	8110027
14,5		3000		0,278	8110028
16,5		3200		0,276	8110029

Reinforced polyamide.



DF	LA	FT N (newton)	FM N (newton)	Kg	COD.
-	9	-	7500	0,17	8115057
-	10,5	-		0,17	8115058

Reinforced polyamide.



DF	LA	FT N (newton)	FM N (newton)	Kg	COD.
-	9	-	7500	0,18	8115036
-	10,5	-		0,17	8115037

Reinforced polyamide, head eyebolt stainless steel.

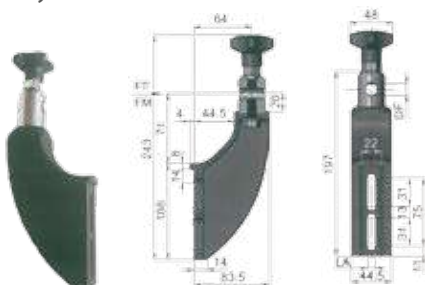

DF	LA	FT N (newton)	FM N (newton)	Kg	COD.
12,5	9	5000	7500	0,49	8115160
14,5		6000		0,47	8115161
16,5		6000		0,44	8115163
12,5	10,5	5000	7500	0,49	8115175
14,5		5000		0,47	8115176
16,5		6000		0,44	8115178

Reinforced polyamide, head eyebolt and bushings in nickel plated brass.



DF	LA	FT N (newton)	FM N (newton)	Kg	COD.
12,5	9	5000	7500	0,49	8115038
14,5		6000		0,47	8115039
16,5		6000		0,44	8115040
12,5	10,5	5000	7500	0,49	8115041
14,5		5000		0,47	8115042
16,5		6000		0,44	8115043

Reinforced polyamide, eyebolt stainless steel and bushings in nickel plated brass.



DF	LA	FT N (newton)	FM N (newton)	Kg	COD.
12,5	9	2600	7500	0,33	8115044
14,5		3500		0,32	8115045
16,5		3500		0,32	8115046
12,5	10,5	2600	7500	0,33	8115047
14,5		3500		0,32	8115048
16,5		3500		0,32	8115049

Adjustable brackets

Reinforced polyamide, eyebolt stainless steel and bushings in nickel plated brass.

**STANDARD BRACKETS**



DF	LA	FT N (newton)	FM N (newton)	Kg	COD.
12,5	9	2200	7500	0,20	8115051
14,5		3000		0,20	8115052
16,5		3000		0,20	8115053
12,5	10,5	2200	7500	0,20	8115054
14,5		3000		0,20	8115055
16,5		3000		0,20	8115056



DF	LA	FT N (newton)	FM N (newton)	Kg	COD.
12,5	9	5000	7500	0,49	8115185
14,5		6000		0,47	8115186
16,5		6000		0,44	8115187
12,5	10,5	5000	7500	0,49	8115190
14,5		6000		0,47	8115191
16,5		6000		0,47	8115193

Reinforced polyamide, head eyebolt and bushings in nickel plated brass.



DF	LA	FT N (newton)	FM N (newton)	Kg	COD.
12,5	9	5000	7500	0,49	8115059
14,5		6000		0,47	8115060
16,5		6000		0,44	8115061
12,5	10,5	5000	7500	0,49	8115062
14,5		6000		0,47	8115063
16,5		6000		0,47	8115064

Reinforced polyamide, fastener in stainless steel.



DF	LA	FT N (newton)	FM N (newton)	Kg	COD.
12,5	9	2600	7500	0,30	8115065
14,5		3500		0,30	8115066
16,5		3500		0,30	8115067
12,5	10,5	2600	7500	0,30	8115068
14,5		3500		0,30	8115069
16,5		3500		0,30	8115070

Adjustable brackets



DF	LA	FT N (newton)	FM N (newton)	Kg	COD.
12,5	9	2200	7500	0,21	8115071
14,5		3000		0,20	8115072
16,5		3000		0,20	8115073
12,5	10,5	2200	7500	0,21	8115074
14,5		3000		0,20	8115075
16,5		3000		0,21	8115076

# Supports

Stainless steel.

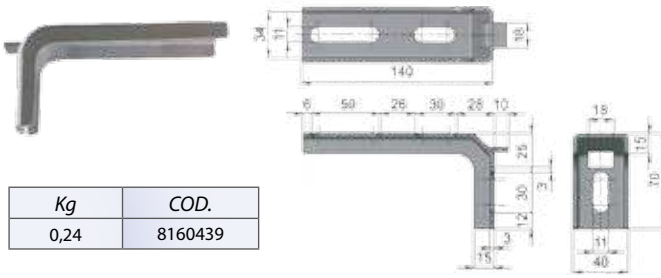

Kg	COD.
0,24	8160439

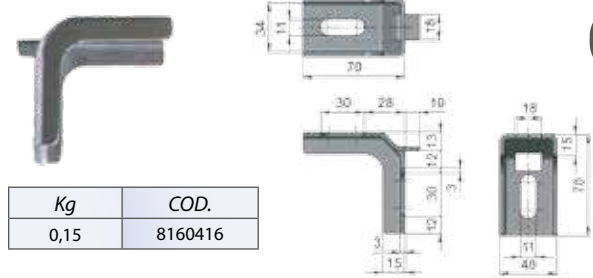

Kg	COD.
0,15	8160416

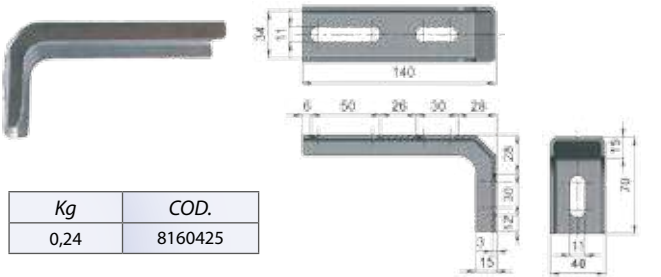

Kg	COD.
0,24	8160425

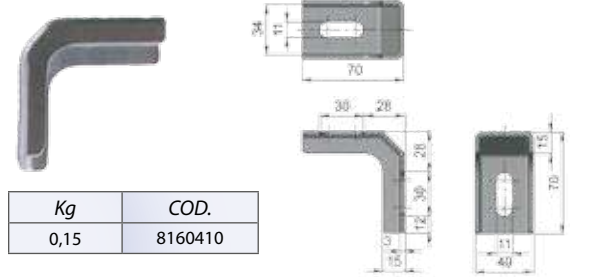

Kg	COD.
0,15	8160410

SUPPORTS

# Support spacer

Reinforced polyamide.

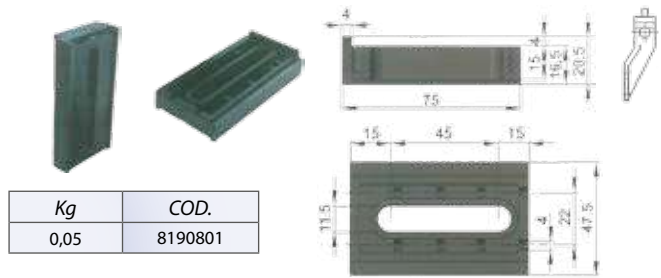

Kg	COD.
0,05	8190801

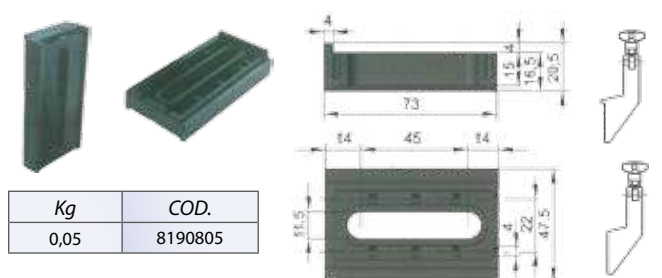

Kg	COD.
0,05	8190805

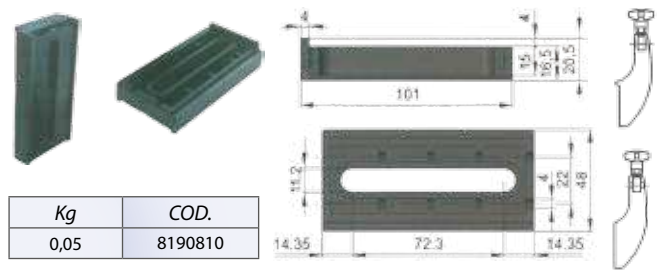

Kg	COD.
0,05	8190810

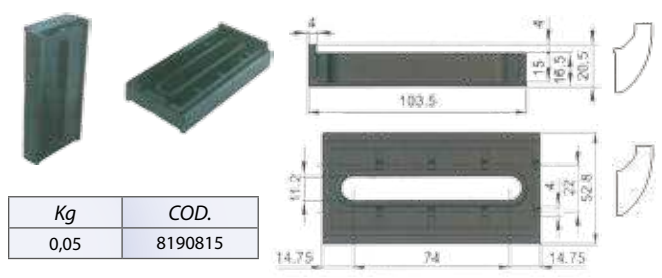

Kg	COD.
0,05	8190815

SUPPORT SPACER

# Knobs

Reinforced polyamide, bushings in nickel plated brass.

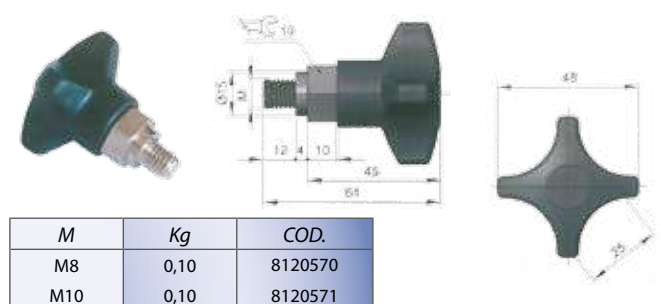

M	Kg	COD.
M8	0,10	8120570
M10	0,10	8120571

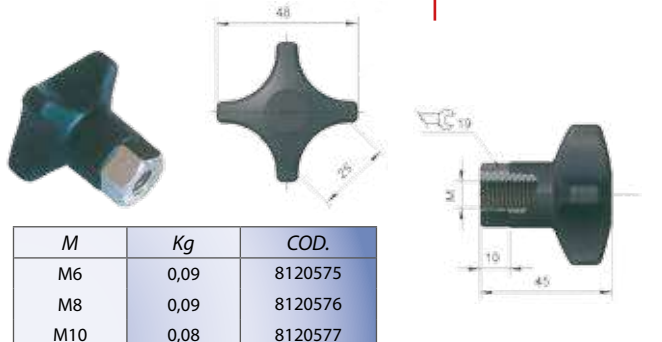

M	Kg	COD.
M6	0,09	8120575
M8	0,09	8120576
M10	0,08	8120577

Supports, Support spacer, Knobs.

Reinforced polyamide, pin in zinc plated steel.

**HANDLES**

M	A	B	C	D	E	F	G	H	Kg	COD.
M6	43	50	35	21	12	6	13	25	0,08	8120691
M8	65	73	46	26,5	15	8	17	30	0,08	8120692
M10	83	93	57	33,5	19	10	22	40	0,09	8120693
M12	104	120	69	40	25	11	24	60	0,10	8120694

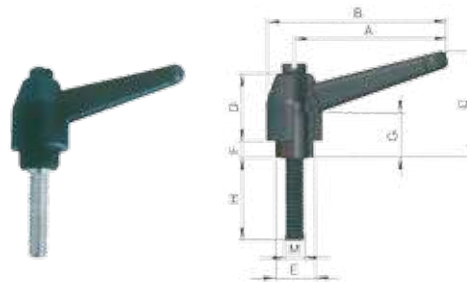

M	A	B	C	D	E	F	G	H	Kg	COD.
M6	43	50	35	21	12	6	13	-	0,02	8120705
M8	65	73	46	26,5	15	8	17	-	0,02	8120706
M10	83	93	57	33,5	19	10	22	-	0,02	8120707
M12	104	120	69	40	25	11	24	-	0,03	8120708

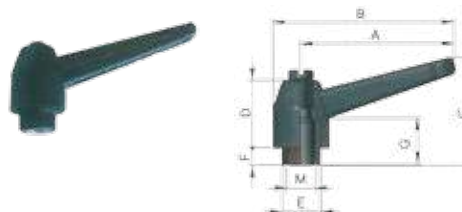

**Heads**

**HEADS**

DF	Mat.	Kg	COD.
12,5	Reinforced Polyamide	0,08	8120107
14,5		0,08	8120108
16,5		0,08	8120109



DF	Mat.	Kg	COD.
12,5	Reinforced Polyamide	0,08	8120101
14,5		0,08	8120102
16,5		0,08	8120103

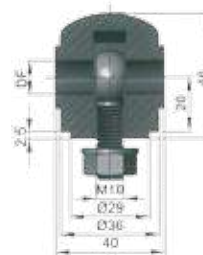

DF	Mat.	Kg	COD.
12,5	Nickel plated	0,18	8120122
14,5		0,18	8120123
16,5	Brass	0,18	8120124
12,5	Stainless Steel	0,18	8120129
14,5		0,17	8120130
16,5		0,17	8120131

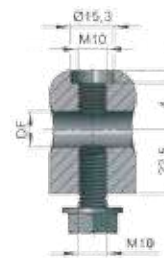

DF	Mat.	H	W	Kg	COD.
12,5	Stainless Steel	40	55	0,28	8120301
		60	75	0,38	8120302
		90	105	0,55	8120303
		130	145	0,77	8120304
14,5		40	56	0,28	8120307
		60	76	0,38	8120308
		90	106	0,55	8120309
		130	146	0,77	8120310
16,5		40	57	0,28	8120315
		60	77	0,38	8120316
		90	107	0,55	8120317
		130	147	0,77	8120318

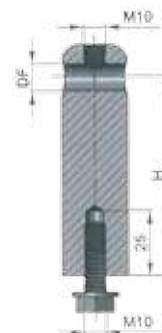

Handles  
Heads



# Heads

Reinforced polyamide.

DF	Kg	COD.
10,5	0,01	8120085

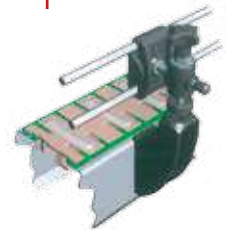
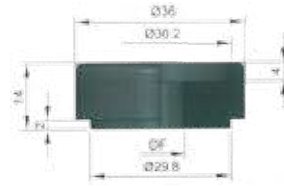

# Adjusting rods

RODS

Flexible PVC. Black colour  
Safety cap.

DF	h	H	Kg	COD.
10	15	18	0,01	7640174
12	16	20	0,01	7640176
15	17	21	0,01	7640179
16	18	23	0,01	7640180
20	20	24,5	0,01	7640181



Spindle not included.

Stainless steel, nut in Stainless steel.



DE	LT	Kg	COD.
12	100	0,09	8220301
12	100	0,11	8220321
12	100	0,13	8220322
14	100	0,12	8220302
15	100	0,14	8220303
16	140	0,16	8220304

For clamps 8210134,  
8210212, 8210525,  
8210270, 8210277

Polyethylene. Black colour  
Strip tube.

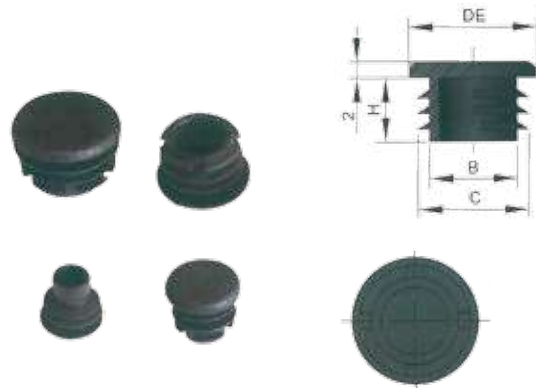

Wall-tube thickness	DE	H	B	C	Kg	COD.
1-1,5	10	8	5,5	8	0,01	7640149
1-1,5	12	8	7	10	0,01	7640152
1-1,5	14	8	9	1,5	0,01	7640154
1-1,5	16	8	11	14	0,01	7640146
1-1,5-2	18	9	12	15,5	0,01	7640147

Stainless steel.



DE	LT	Kg	COD.
12	100	0,09	8220335
12	150	0,13	8220380
14	100	0,12	8220336
15	100	0,14	8220337
16	100	0,14	8220338

For clamps 8210038,  
8210039, 8210040,  
8210071, 8210072,  
8210073, 8210112,  
8210155, 8210142,  
8210161, 8210317,  
8210184,



For clamps  
8210014, 8210015,  
8210016, 8210050,  
8210051, 8210052,  
8210121, 8210151,  
8210138, 8210157,  
8210109, 8210095.

DE	LT	Kg	COD.
10	80	0,04	8222780
10	80	0,07	8222790
12	100	0,09	8220339
14	100	0,12	8220340
15	100	0,14	8220341
16	100	0,16	8220342

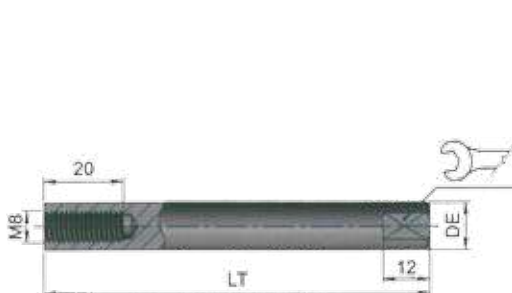

For clamps 8210038,  
8210212, 8210525,  
8210270, 8210277

DE	LT	Kg	COD.
12	100	0,09	8220343
14	100	0,12	8220344
15	100	0,14	8220345
16	100	0,16	8220342

Reinforced polyamide.

**DOUBLE CLAMP**



DV	DE	L	Kg	COD.
12	-	-	0,11	8210212

Reinforced polyamide, pin, washer and nut in stainless steel.

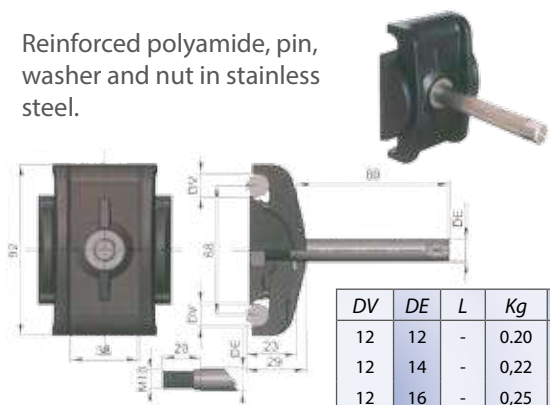

DV	DE	L	Kg	COD.
12	12	-	0,20	8240211
12	14	-	0,22	8240214
12	16	-	0,25	8240215

Reinforced polyamide, fastener in stainless steel.

**SINGLE CLAMP**

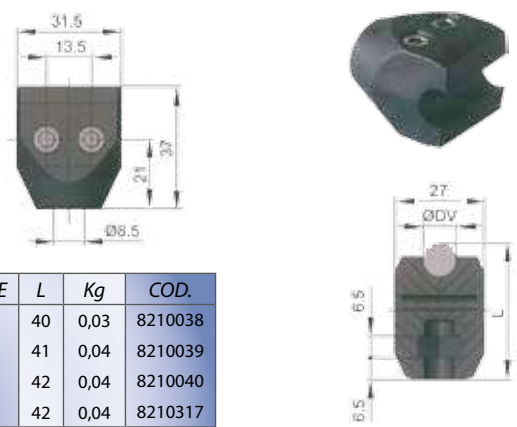

DV	DE	L	Kg	COD.
8	-	40	0,03	8210038
10	-	41	0,04	8210039
12	-	42	0,04	8210040
14	-	42	0,04	8210317

Reinforced polyamide, pin and fastener in stainless steel.



DV	DE	L	Kg	COD.
8	12	40	0,14	8240041
	14	40	0,17	8240042
	16	40	0,20	8240043
10	12	41	0,14	8240044
	14	41	0,17	8240045
	16	41	0,20	8240046
12	12	42	0,14	8240047
	14	42	0,17	8240048
	16	42	0,20	8240049
14	12	42	0,14	8240231
	16	42	0,17	8240232
				8240233

Reinforced polyamide, fastener in stainless steel.

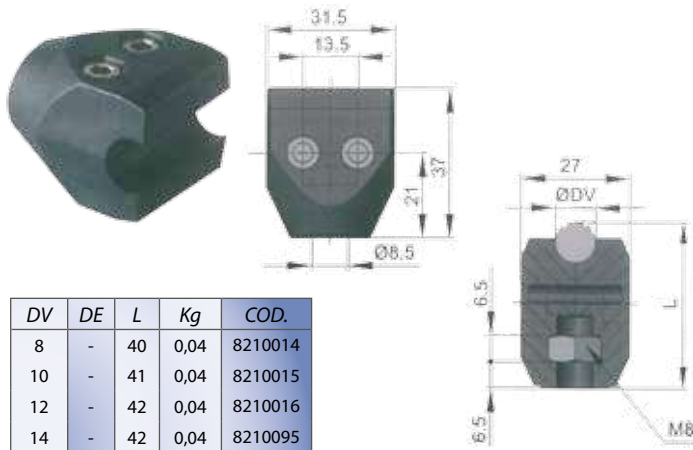

DV	DE	L	Kg	COD.
8	-	40	0,04	8210014
10	-	41	0,04	8210015
12	-	42	0,04	8210016
14	-	42	0,04	8210095

Reinforced polyamide, pin and fastener in stainless steel.

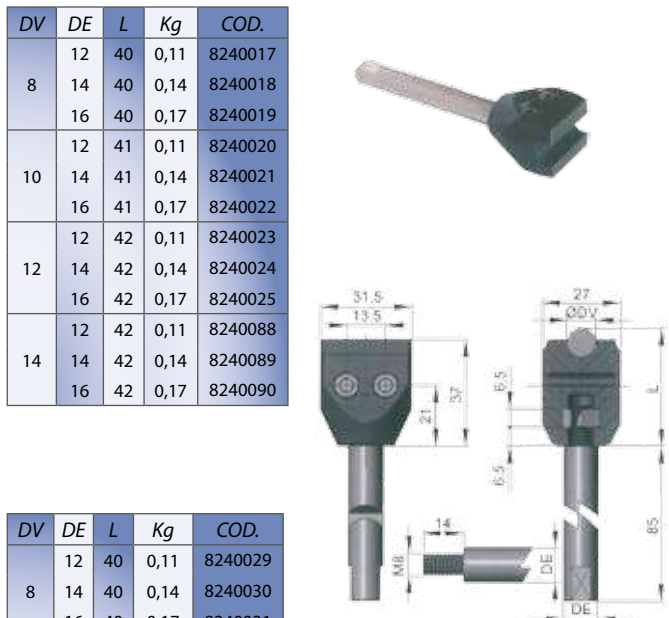

DV	DE	L	Kg	COD.
8	12	40	0,11	8240017
	14	40	0,14	8240018
	16	40	0,17	8240019
10	12	41	0,11	8240020
	14	41	0,14	8240021
	16	41	0,17	8240022
12	12	42	0,11	8240023
	14	42	0,14	8240024
	16	42	0,17	8240025
14	12	42	0,11	8240088
	14	42	0,14	8240089
	16	42	0,17	8240090

Clamps for round profile guides

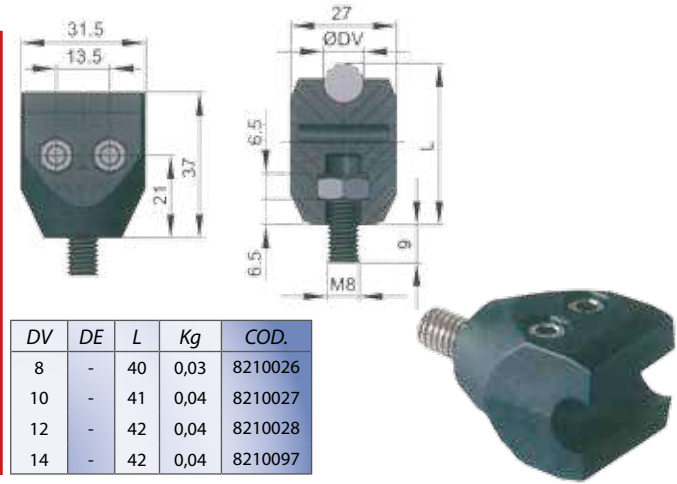

DV	DE	L	Kg	COD.
8	-	40	0,03	8210026
10	-	41	0,04	8210027
12	-	42	0,04	8210028
14	-	42	0,04	8210097

DV	DE	L	Kg	COD.
8	12	40	0,11	8240029
	14	40	0,14	8240030
	16	40	0,17	8240031
10	12	41	0,11	8240032
	14	41	0,14	8240033
	16	41	0,17	8240034
12	12	42	0,11	8240035
	14	42	0,14	8240036
	16	42	0,17	8240037
14	12	42	0,11	8240091
	14	42	0,14	8240092
	16	42	0,17	8240093

# Clamps for round profile guides

Reinforced polyamide, fastener in stainless steel.



DV	DE	L	Kg	COD.
8	-	41	0,07	8210071
10	-	42	0,07	8210072
12	-	43	0,07	8210073
14	-	44	0,07	8210184



Reinforced polyamide, pin and fastener in stainless steel.

DV	DE	L	Kg	COD.
8	12	41	0,15	8240062
	14	41	0,18	8240063
	16	41	0,21	8240064
10	12	42	0,15	8240065
	14	42	0,18	8240066
	16	42	0,21	8240067
12	12	43	0,15	8240068
	14	43	0,18	8240069
	16	43	0,21	8240070
14	12	43	0,15	8240191
	14	43	0,18	8240192
	16	43	0,21	8240193



**SINGLE CLAMP**



DV	DE	L	Kg	COD.
8	-	41	0,07	8210050
10	-	42	0,07	8210051
12	-	43	0,07	8210052
14	-	43	0,07	8210109

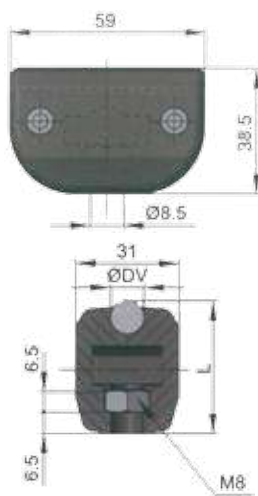

DV	DE	L	Kg	COD.
8	12	41	0,15	8240053
	14	41	0,18	8240054
	16	41	0,21	8240054
10	12	42	0,15	8240056
	14	42	0,18	8240057
	16	42	0,21	8240058
12	12	43	0,15	8240059
	14	43	0,18	8240060
	16	43	0,21	8240061
14	12	43	0,15	8240170
	14	43	0,18	8240171
	16	43	0,21	8240172

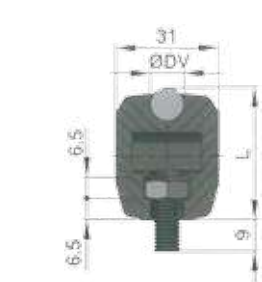

DV	DE	L	Kg	COD.
8	-	41	0,07	8210074
10	-	42	0,07	8210075
12	-	43	0,07	8210076
14	-	43	0,07	8210239



DV	DE	L	Kg	COD.
8	12	41	0,15	8240077
	14	41	0,18	8240078
	16	41	0,21	8240079
10	12	42	0,15	8240080
	14	42	0,18	8240081
	16	42	0,21	8240082
12	12	43	0,15	8240083
	14	43	0,18	8240084
	16	43	0,21	8240085
14	12	43	0,15	8240251
	14	43	0,18	8240252
	16	43	0,21	8240253

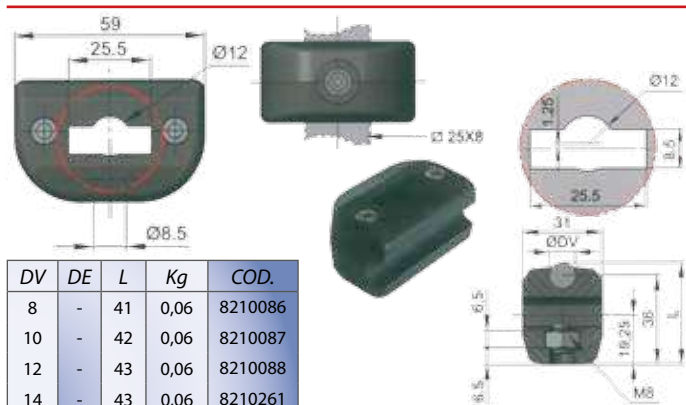

DV	DE	L	Kg	COD.
8	-	41	0,06	8210086
10	-	42	0,06	8210087
12	-	43	0,06	8210088
14	-	43	0,06	8210261

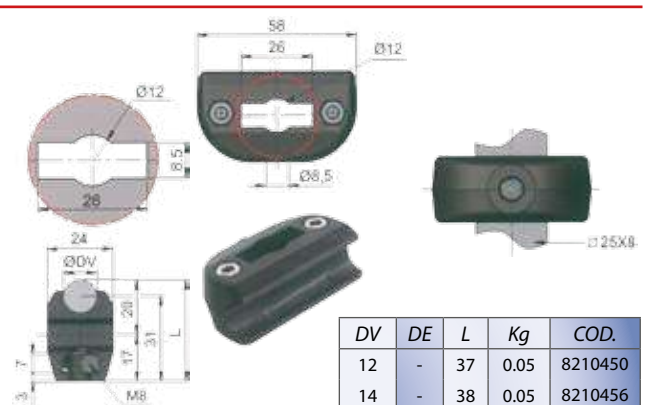

DV	DE	L	Kg	COD.
12	-	37	0,05	8210450
14	-	38	0,05	8210456

Clamps for round profile guides

Reinforced polyamide.

**DOUBLE CLAMP**

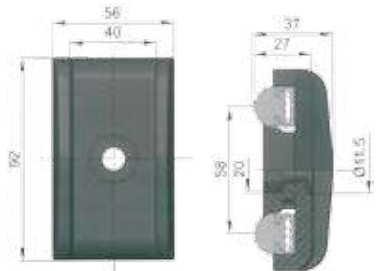

DE	Kg	COD.
-	0,10	8210525

Reinforced polyamide, pin, washer and nut in stainless steel.



DE	Kg	COD.
12	0,18	8240118
14	0,20	8240119
16	0,21	8240120

Reinforced polyamide, fastener in stainless steel.

**SINGLE CLAMP**

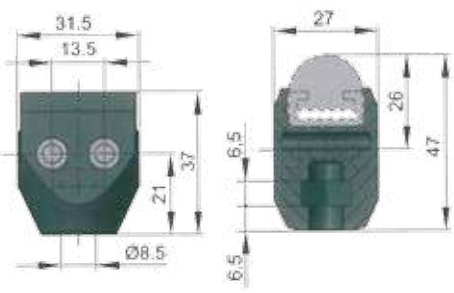

DE	Kg	COD.
-	0,03	8210112



DE	Kg	COD.
12	0,11	8240114
14	0,13	8240115
16	0,15	8240116

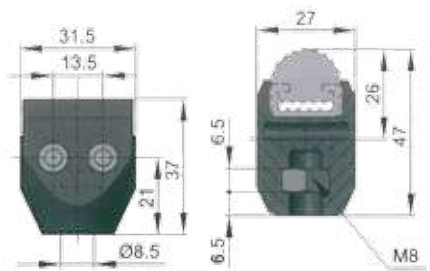

DE	Kg	COD.
-	0,03	8210121

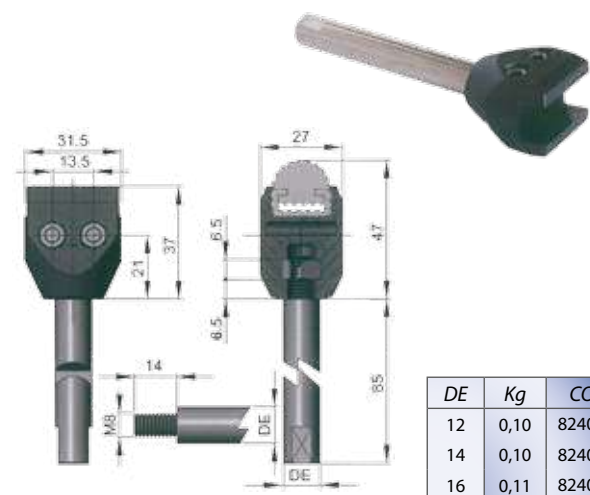

DE	Kg	COD.
12	0,10	8240122
14	0,10	8240123
16	0,11	8240124

Clamps for "MC" guides

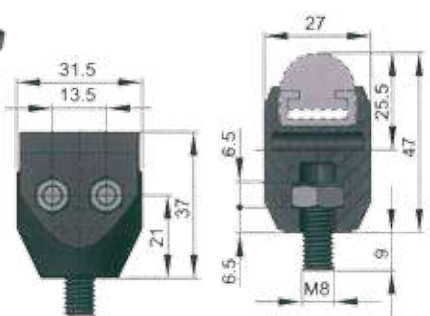

DE	Kg	COD.
-	0,03	8210125

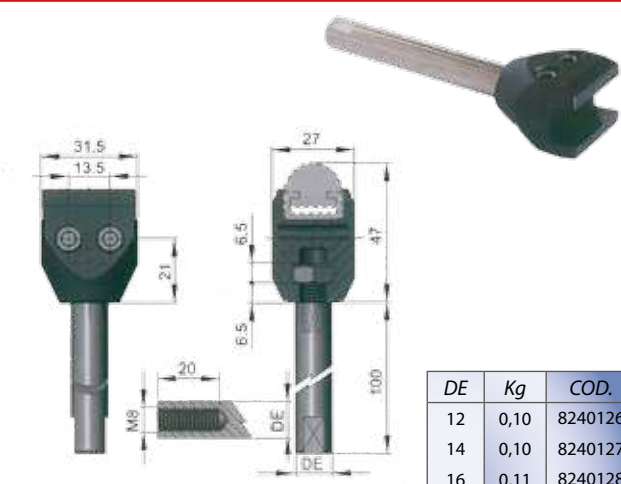

DE	Kg	COD.
12	0,10	8240126
14	0,10	8240127
16	0,11	8240128

# Clamps for "MC" guides

Reinforced polyamide, fastener in stainless steel.

DE	Kg	COD.
-	0,06	8210155

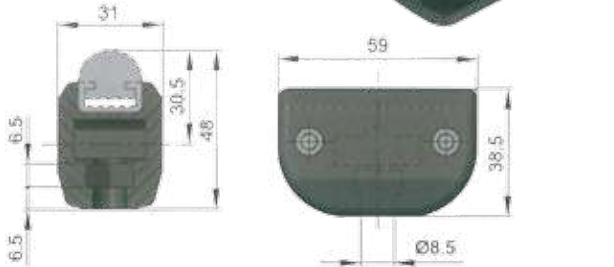

Reinforced polyamide, pin and fastener in stainless steel.

**SINGLE CLAMP FOR "MC" GUIDES**



DE	Kg	COD.
12	0,14	8240156
14	0,14	8240173
16	0,15	8240174

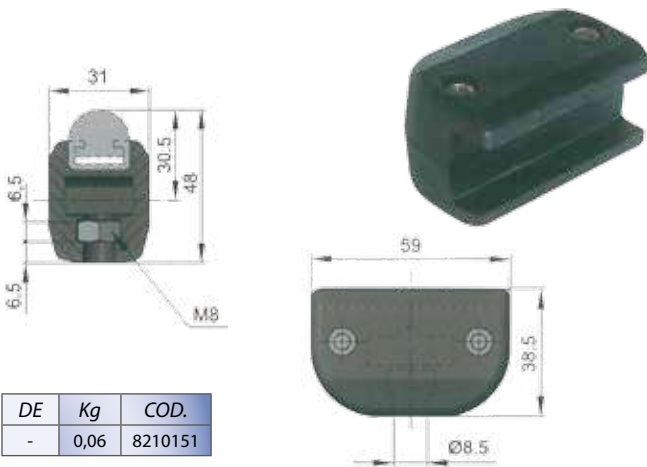

DE	Kg	COD.
-	0,06	8210151

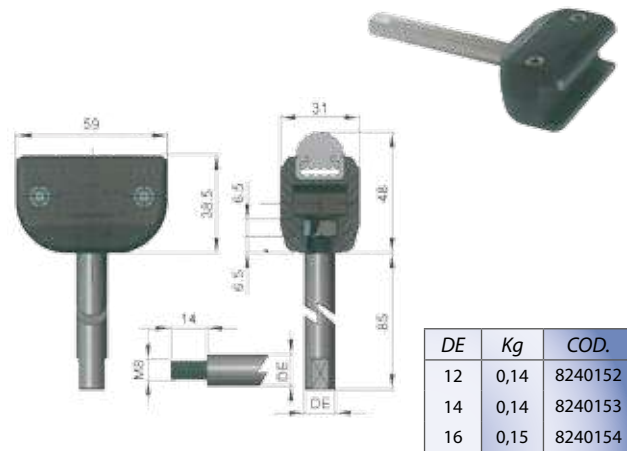

DE	Kg	COD.
12	0,14	8240152
14	0,14	8240153
16	0,15	8240154

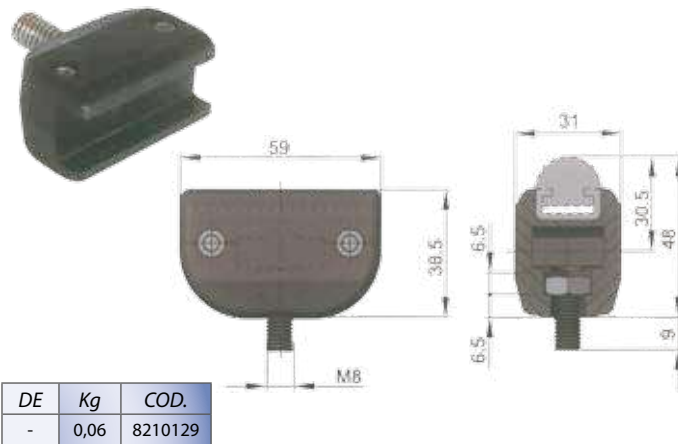

DE	Kg	COD.
-	0,06	8210129

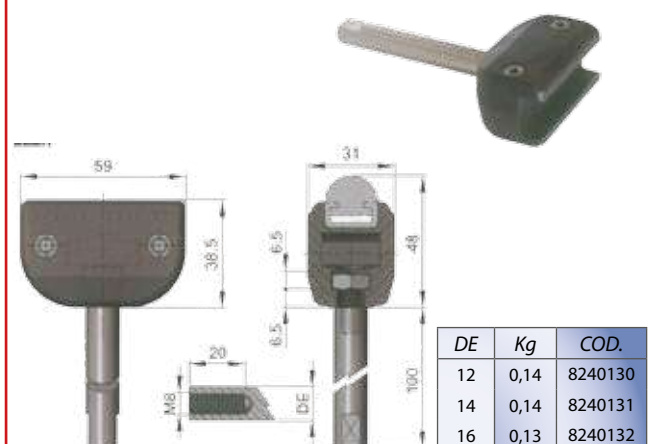

DE	Kg	COD.
12	0,14	8240130
14	0,14	8240131
16	0,13	8240132

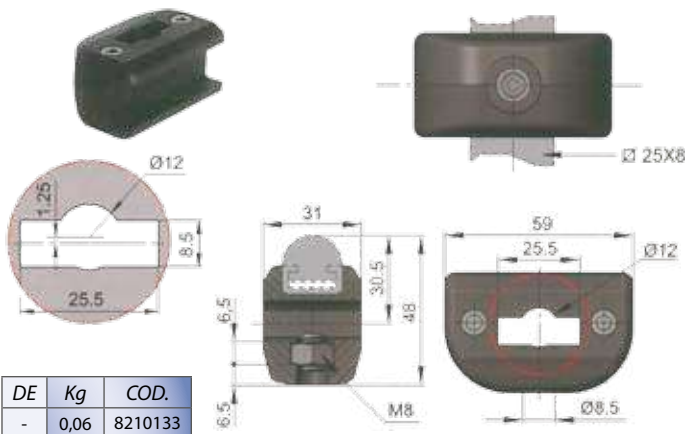

DE	Kg	COD.
-	0,06	8210133



Colour	Guide	L	Kg	COD.
Green	-	50	0,21	P20350
Black	-	50	0,21	P30350
Green	C2010SS	2	0,70	PSS20350L2
		3		PSS20350L3
Green	C2010	2	0,70	PZN20350L2
		3		PZN20350L3
Black	C2010SS	2	0,70	PSS30350L2
		3		PSS30350L3
Black	C2010	2	0,70	PZN30350L2
		3		PZN30350L3

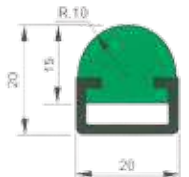

Clamps for "MC" guides

Reinforced polyamide.

**DOUBLE CLAMP**

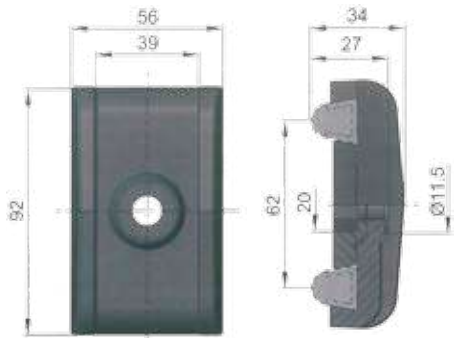

DE	Kg	COD.
-	0,09	8210134

Reinforced polyamide, pin, washer and nut in stainless steel.



DE	Kg	COD.
12	0,18	8240135
14	0,20	8240136
16	0,21	8240137

Reinforced polyamide, fastener in stainless steel.

**SINGLE CLAMP**

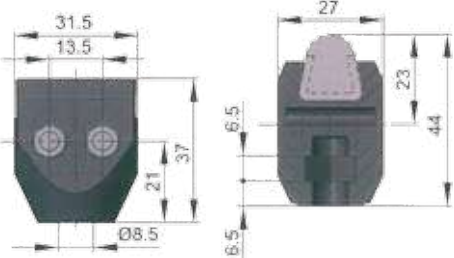

DE	Kg	COD.
-	0,03	8210142

Reinforced polyamide, pin and fastener in stainless steel.



DE	Kg	COD.
12	0,11	8240143
14	0,13	8240144
16	0,15	8240145

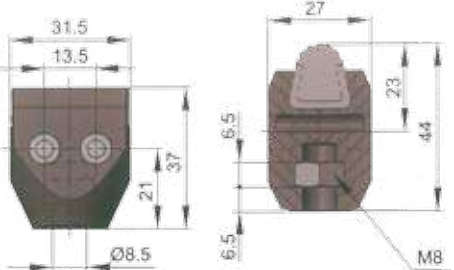

DE	Kg	COD.
-	0,03	8210138

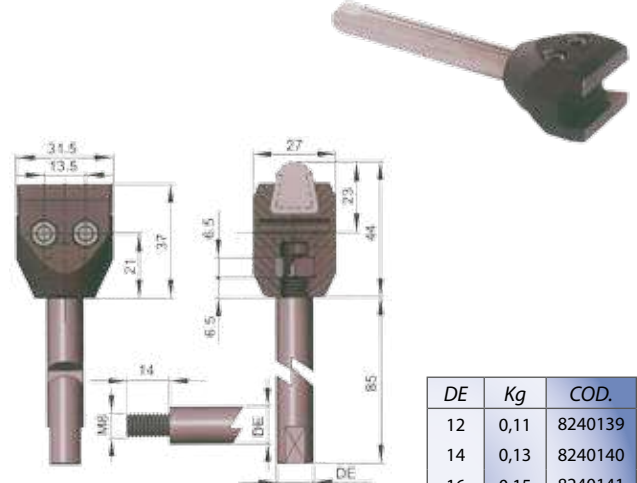

DE	Kg	COD.
12	0,11	8240139
14	0,13	8240140
16	0,15	8240141

Clamps for conical side guides

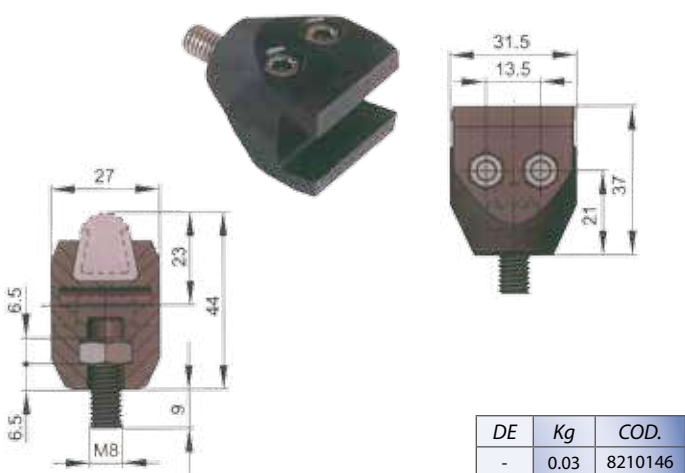

DE	Kg	COD.
-	0,03	8210146

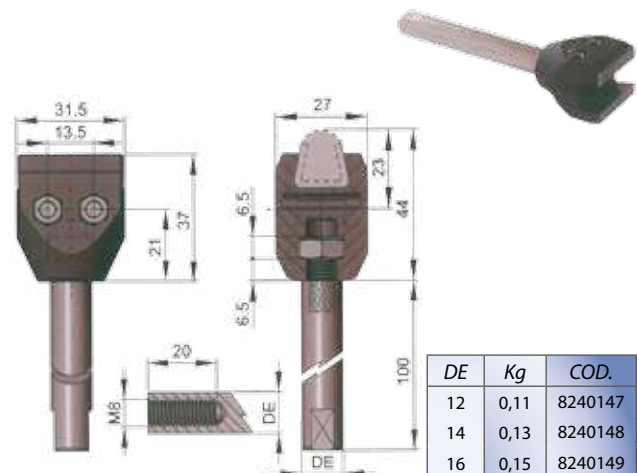

DE	Kg	COD.
12	0,11	8240147
14	0,13	8240148
16	0,15	8240149

# Clamps for conical side guides

Reinforced polyamide, fastener in stainless steel.

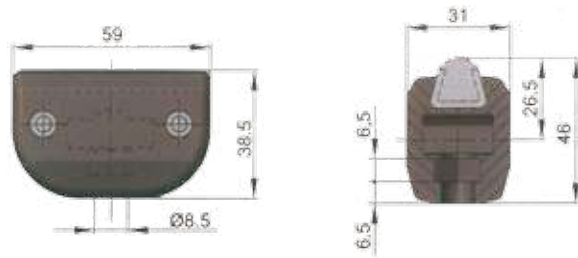

DE	Kg	COD.
-	0,06	8210161

DE	Kg	COD.
-	0,06	8210157

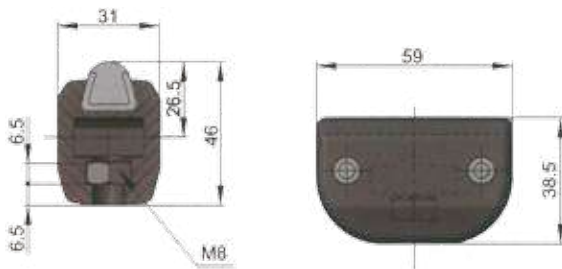

DE	Kg	COD.
-	0,06	8210165

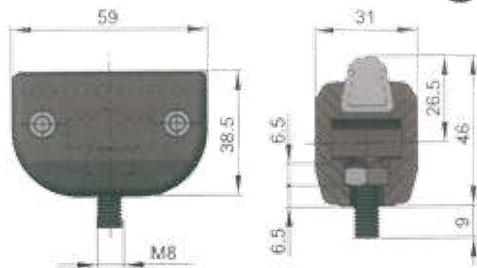

DE	Kg	COD.
-	0,06	8210169

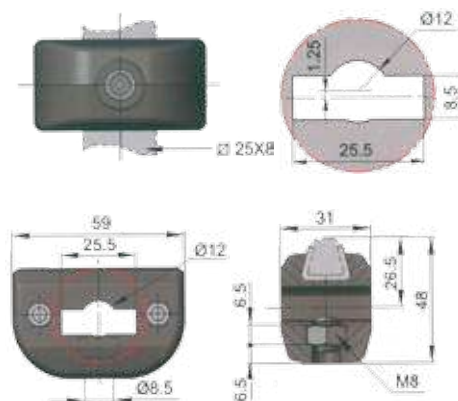

Reinforced polyamide, pin and fastener in stainless steel.



DE	Kg	COD.
12	0,14	8240162
14	0,16	8240163
16	0,18	8240164

DE	Kg	COD.
12	0,14	8240158
14	0,16	8240159
16	0,18	8240160

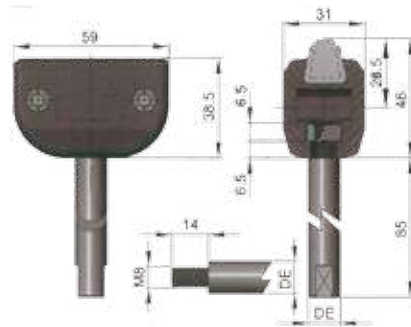

DE	Kg	COD.
12	0,14	8240166
14	0,16	8240167
16	0,18	8240168



DE	Kg	COD.
-	0,05	8210461

Stainless steel.

**GUIDE JOINT**

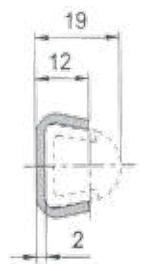
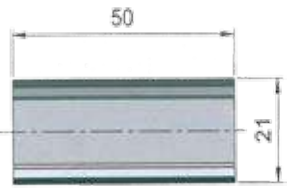

Kg	COD.
0,03	8214620

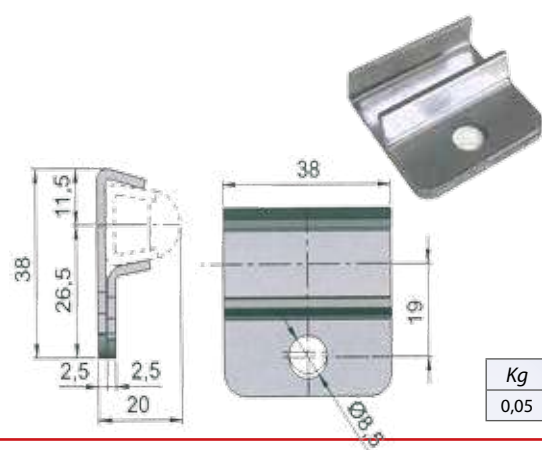

Kg	COD.
0,05	8214680

**DOUBLE CLAMP**

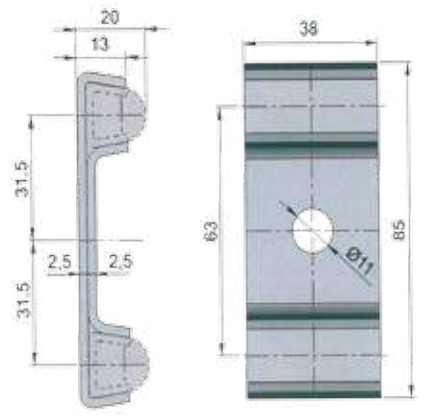

Kg	COD.
0.13	8214691

Reinforced polyamide.

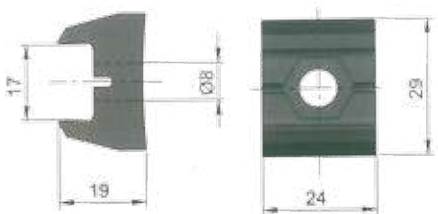

Kg	COD.
0.01	8210367

UHMW 1000 "DESLIDUR" Polyethylene.

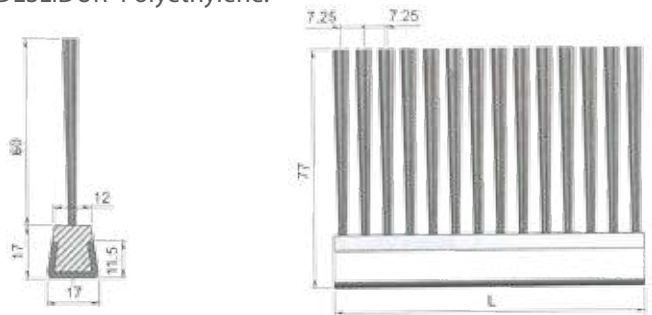

Colour	Guide	L	Kg	COD.
White	SS	500	0,72	CSS1010X05

*Extra side guides*

Self-lubricating polyethylene.

Clamps for conical side guides/  
Extra side guides

L	Kg	COD.
3	1,0	P30447.15
6	2,0	P30447.20

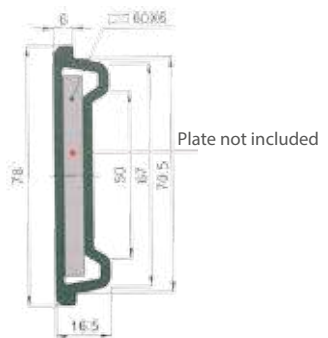

- Coefficient of linear expansion:  $2.5 \cdot 10^{-4} \text{ } ^\circ\text{C}^{-1}$
- working temperature: -35°C - +70°C
- Minimum bending radius: 200 mm.

Reinforced polyamide, pin and fastener in stainless steel.

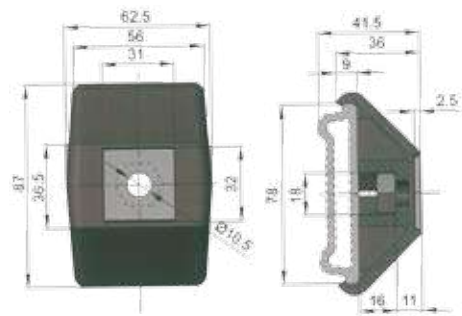

Kg	COD.
0,08	8210270





Reinforced polyamide, pin and washer in stainless steel, nut in nickel plated brass.

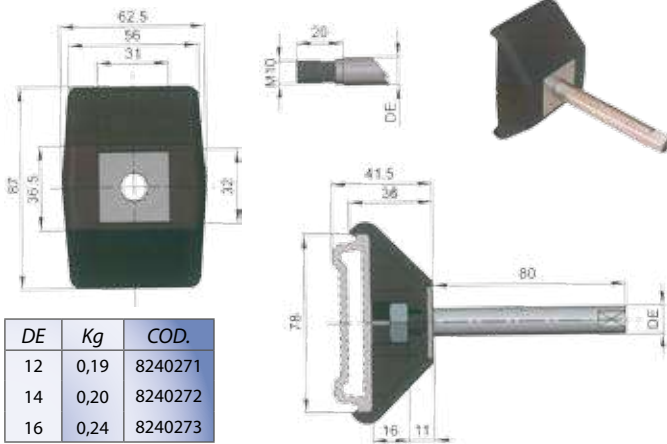

DE	Kg	COD.
12	0,19	8240271
14	0,20	8240272
16	0,24	8240273

Self-lubricating polyethylene

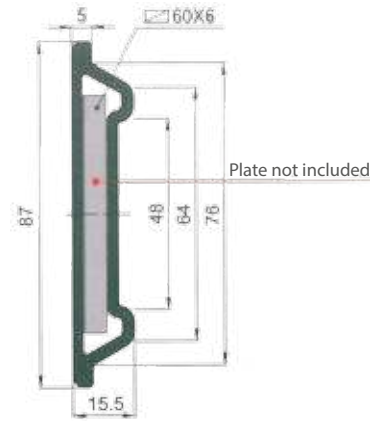

L	Kg	COD.
3	1.0	P30450.15
6	2.0	P30450.20

EXTRA  
SIDE  
GUIDES

Reinforced polyamide, fastener in stainless steel.

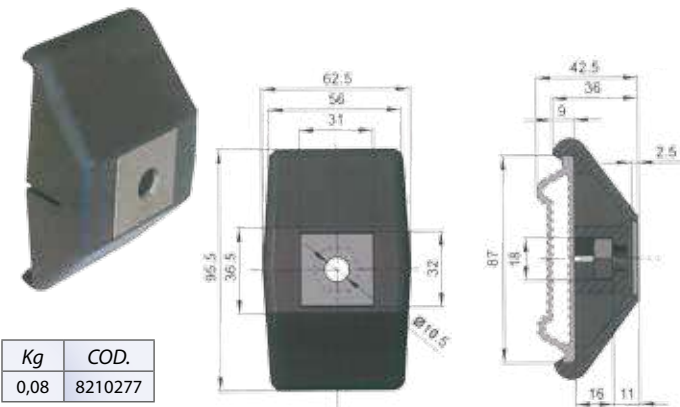

Kg	COD.
0,08	8210277

Reinforced polyamide, pin and washer in stainless steel, nut in nickel plated brass.

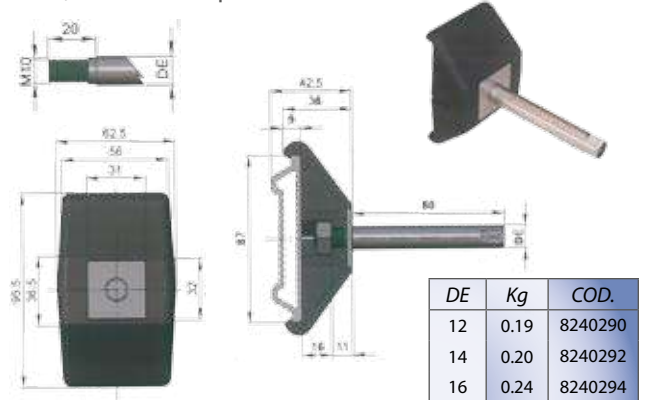

DE	Kg	COD.
12	0.19	8240290
14	0.20	8240292
16	0.24	8240294

Reinforced polyamide.

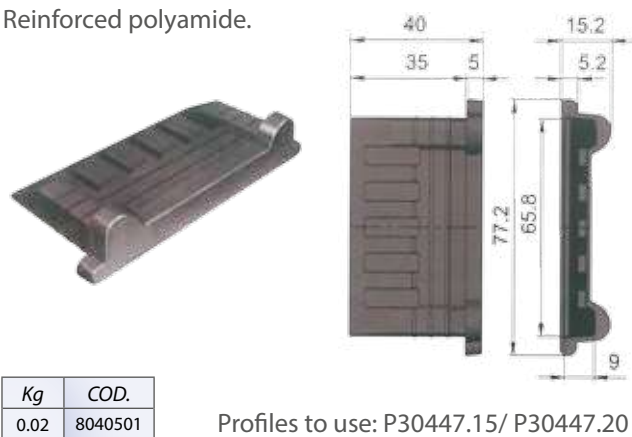

Kg	COD.
0.02	8040501

Profiles to use: P30447.15/ P30447.20

Reinforced polyamide.

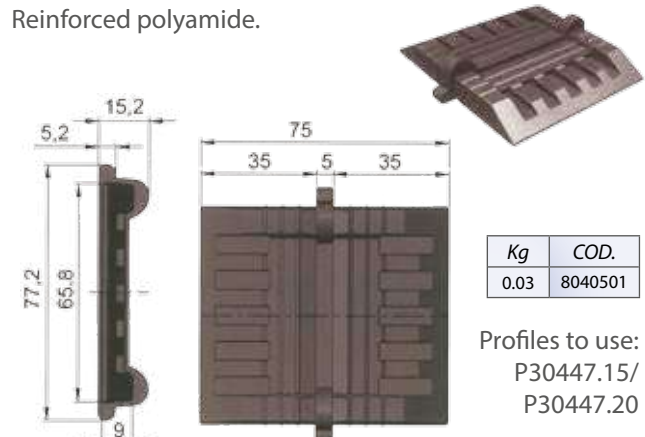

Kg	COD.
0.03	8040501

Profiles to use:  
P30447.15/  
P30447.20



Kg	COD.
0.02	8040560

Profiles to use: P30450.15/ P30450.20

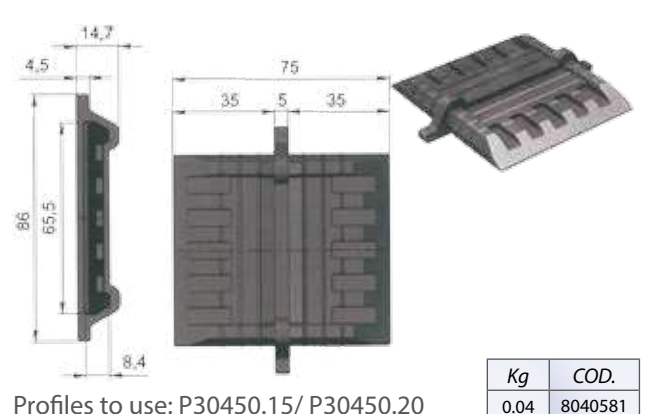

Kg	COD.
0.04	8040581

Profiles to use: P30450.15/ P30450.20

Stainless steel.

**GUIDE**

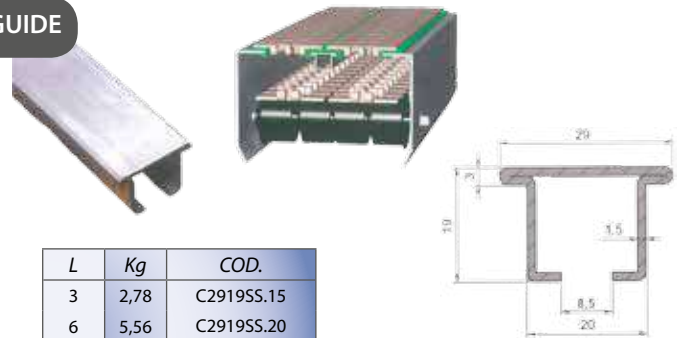

L	Kg	COD.
3	2,78	C2919SS.15
6	5,56	C2919SS.20

UHMW 1000 "DESLIDUR" Polyethylene.

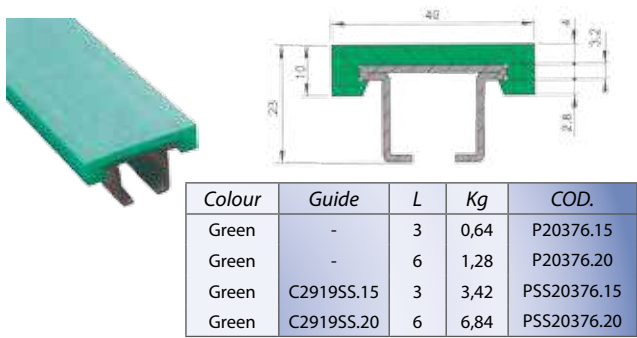

Colour	Guide	L	Kg	COD.
Green	-	3	0,64	P20376.15
Green	-	6	1,28	P20376.20
Green	C2919SS.15	3	3,42	PSS20376.15
Green	C2919SS.20	6	6,84	PSS20376.20

UHMW 1000 "DESLIDUR" Polyethylene.

Colour	Guide	L	Kg	COD.
Green	-	3	0,67	P20378.15
Green	-	6	1,34	P20378.20
Green	C2919SS.15	3	3,45	PSS20378.15
Green	C2919SS.20	6	6,90	PSS20378.20

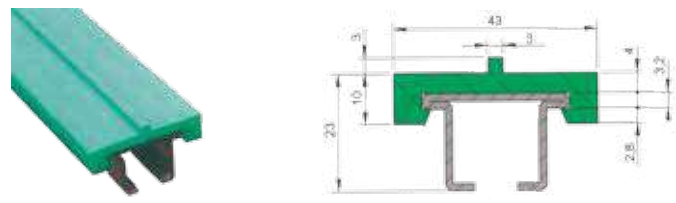

*Accessories*

Reinforced polyamide.

**CONNECTING ELEMENT**

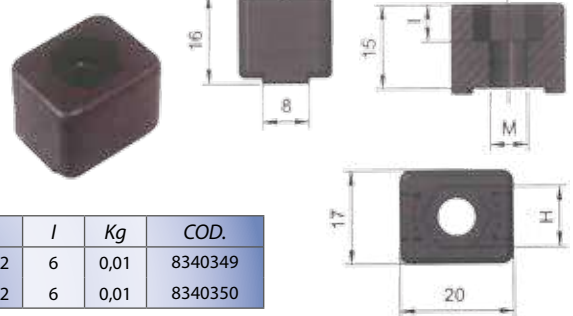

H	M	I	Kg	COD.
10	Ø6,2	6	0,01	8340349
13	Ø8,2	6	0,01	8340350

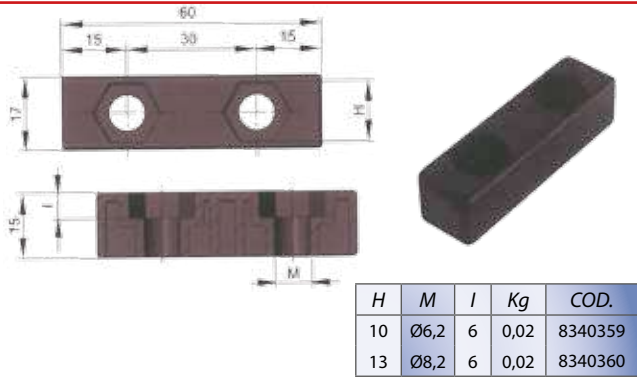

H	M	I	Kg	COD.
10	Ø6,2	6	0,02	8340359
13	Ø8,2	6	0,02	8340360

**SLIDING SHOE**

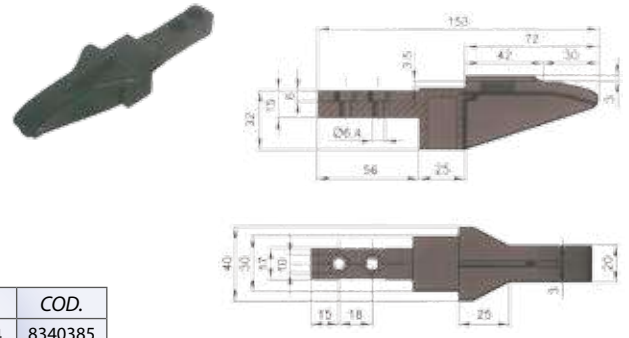

Kg	COD.
0.04	8340385

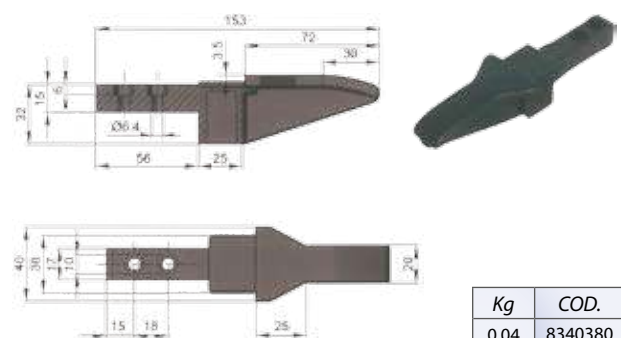

Kg	COD.
0.04	8340380

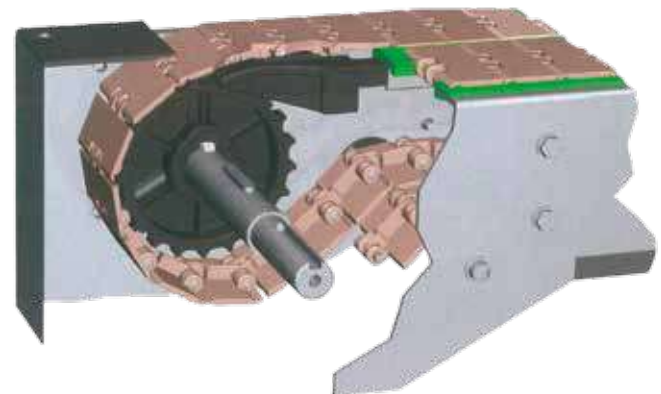

# Drip tray supports

Reinforced polyamide - Stainless steel.

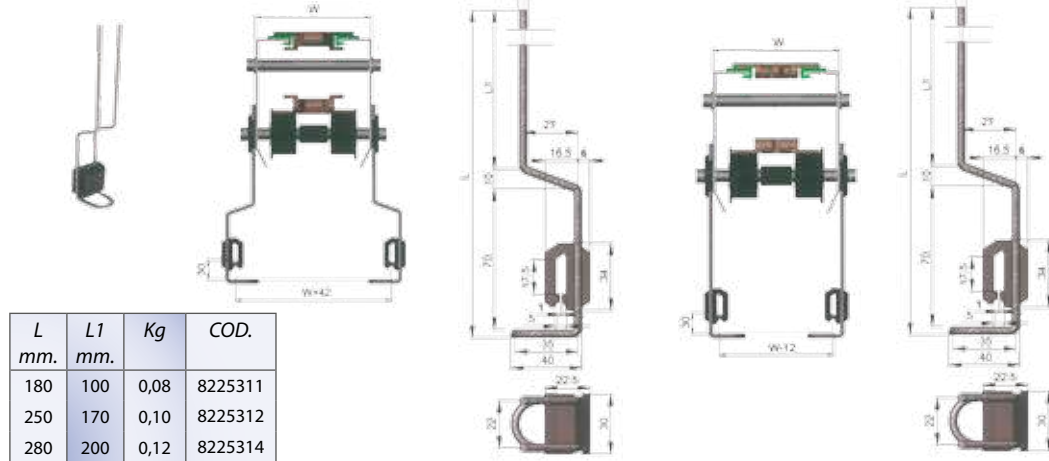

**DRIP TRAY SUPPORTS**

L mm.	L1 mm.	Kg	COD.
180	100	0,08	8225311
250	170	0,10	8225312
280	200	0,12	8225314

L mm.	L1 mm.	Kg	COD.
250	-	0,08	8226218
400	-	0,10	8226219

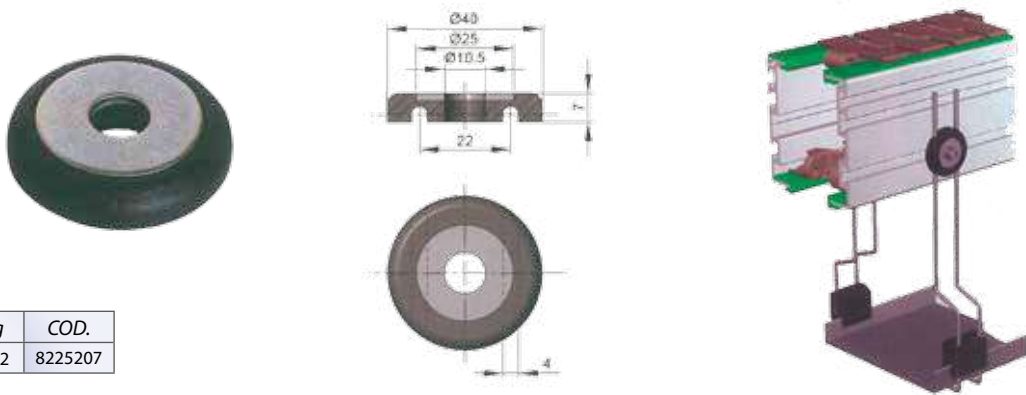

**FIXING WASHER**

Kg	COD.
0,02	8225207

# Cross block and photocell accessories

Reinforced polyamide.

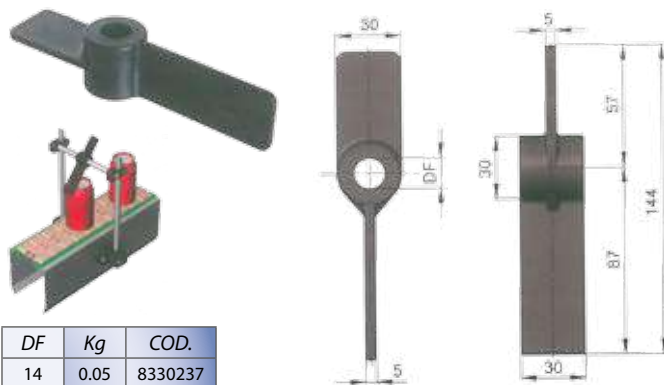

DF	Kg	COD.
14	0.05	8330237

Reinforced polyamide, fastener in stainless steel.

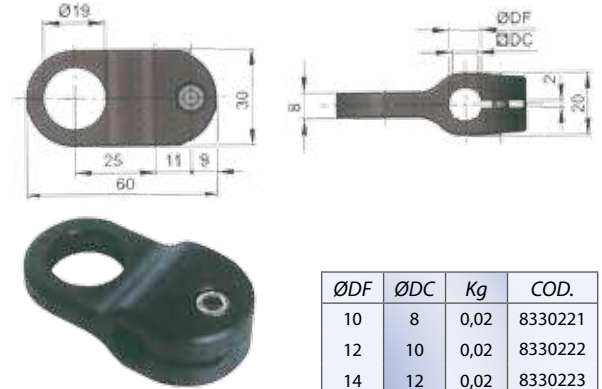

ØDF	ØDC	Kg	COD.
10	8	0,02	8330221
12	10	0,02	8330222
14	12	0,02	8330223

ØDF	ØDC	Kg	COD.
10	8	0,03	8330227
12	10	0,03	8330228
14	12	0,03	8330229

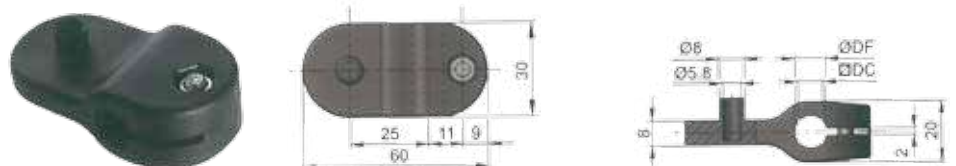

Drip tray supports/ Cross block and photocell accessories

Reinforced polyamide

DF	Kg	COD.
12	0,1	8330301
14	0,1	8330303
15	0,1	8330305
16	0,1	8330306
18	0,1	8330308
20	0,1	8330310

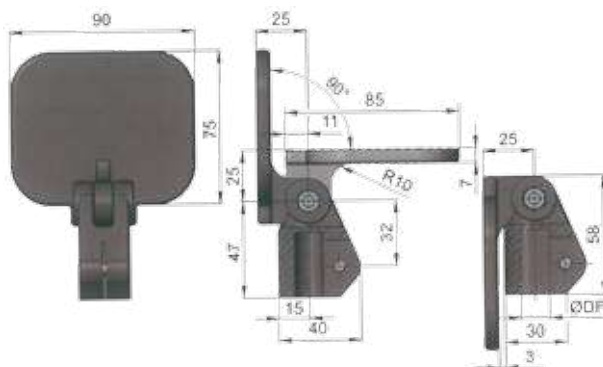

Reinforced polyamide, fastener in stainless steel.

**CROSS BLOCK**



ØDF	ØDC	Kg	COD.
18	15	0.20	8330648
20	18	0.19	8330650

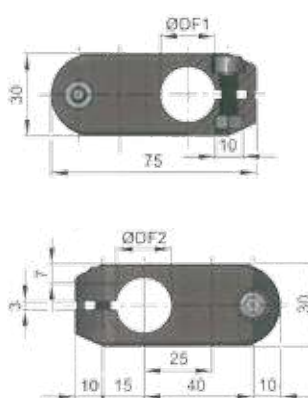

ØDF	ØDC	Kg	COD.
14	14	0.07	8330194
14	15	0.07	8330195
14	16	0.07	8330196
15	15	0.07	8330197
15	16	0.07	8330198
16	16	0.07	8330199
18	18	0.07	8330201
20	20	0.07	8330202

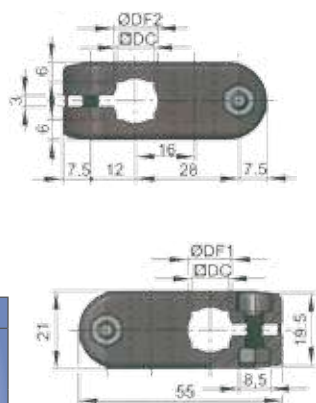

ØDF1	ØDF2	ØDC	Kg	COD.
10	10	8	0,03	8330187
12	12	10	0,03	8330189
14	14	12	0,03	8330191



ØDF	ØDC	Kg	COD.
14	14	0,09	8330740
15	15	0,09	8330745
16	16	0,09	8330746
18	18	0,09	8330748
20	20	0,09	8330750

Reinforced polyamide, fastener in stainless steel.



Detail x

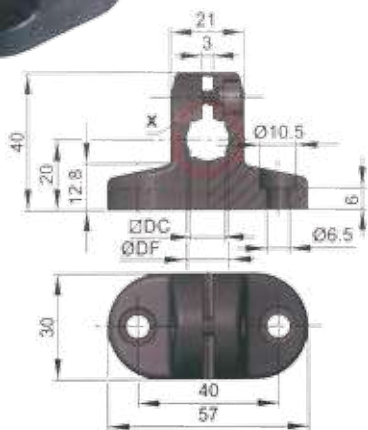
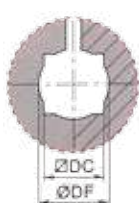

ØDF	ØDC	Kg	COD.
10	8	0,03	8330215
12	10	0,03	8330216
14	12	0,03	8330217

Reinforced polyamide.



For cross block:  
8330215, 8330216,  
8330217

H	Kg	COD.
4	0.01	8330890
6	0.02	8330895

# Cross block and photocell accessories

Reinforced polyamide, fastener in stainless steel.

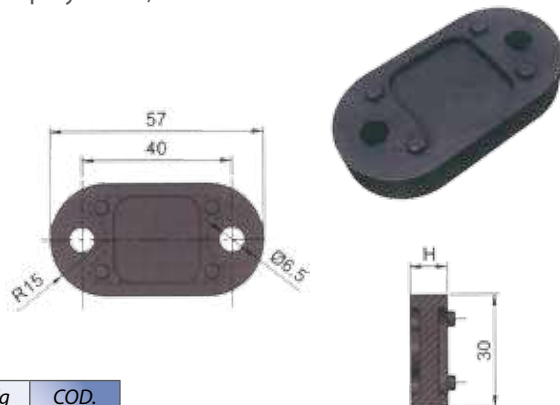

H	Kg	COD.
8	0,02	8330896
10	0,02	8330897
12	0,02	8330899

For cross block:  
8330215, 8330216,  
8330217

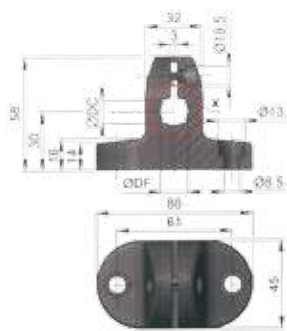

**CROSS  
BLOCK**

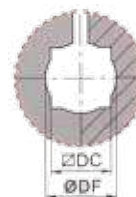

ØDF	DC	Kg	COD.
14	12	0,09	8330270
16	14	0,09	8330271
18	16	0,09	8330273
20	18	0,09	8330275

Reinforced polyamide.

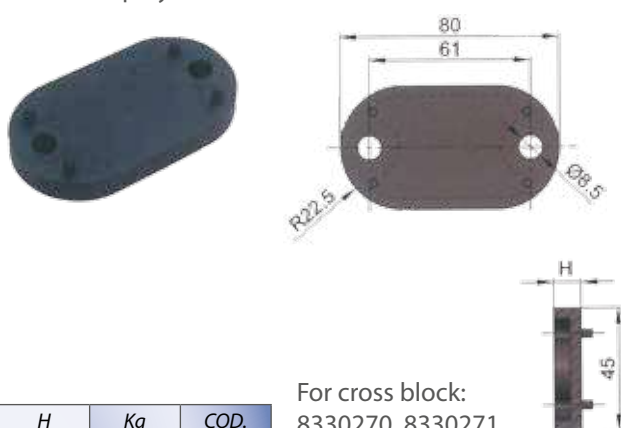

H	Kg	COD.
10	0,03	8330901

For cross block:  
8330270, 8330271,  
8330273, 8330275

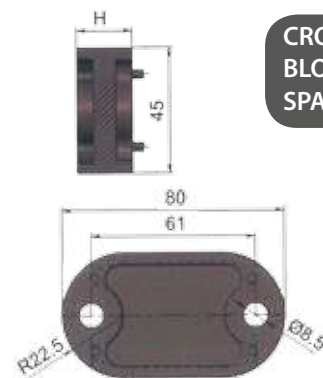

**CROSS  
BLOCK  
SPACER**

H	Kg	COD.
20	0,06	8330905

For cross block:  
8330270, 8330271,  
8330273, 8330275

## Frame system

Reinforced polyamide.

For tube: Ø25x25x1,5 mm.

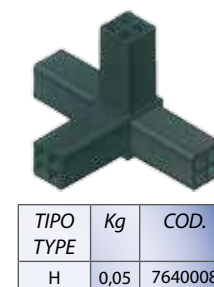

Cross block and photocell accessories/  
Frame system

Reinforced polyamide, fastener in stainless steel.

**CONNECTING GUIDE**

TIPO TYPE	Kg	COD.
AT	0,12	7645101

For tube: Ø25x25x1,5 mm.

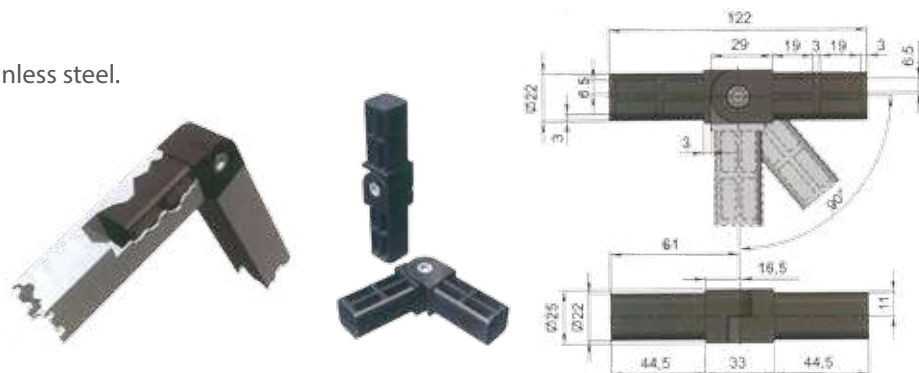

Stainless steel.

**STRUCTURAL FIXATION SUPPORT**

L	Kg	COD.
50mm.	0,09	7640405
100mm.	0,15	7640410
150mm.	0,20	7640415

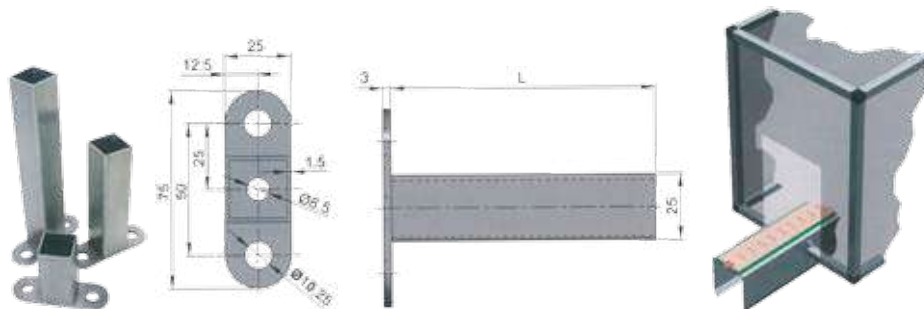

Anodized aluminium - stainless steel.

**25X25X1.5  
STRUCTURE  
OR PAVEMENT  
TUBE**

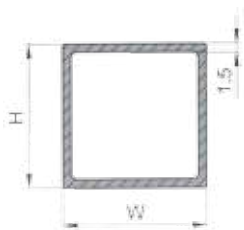

Polyethylene black colour.

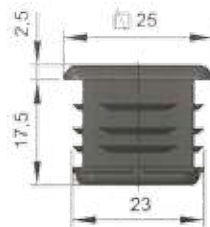

Kg	COD.
0,01	7640110

Polyethylene black colour.

**RUNNER PROFILES**



Cod: 7640312



Cod: 7640301

L	Kg	COD.
2	0,85	7640312
2	0,53	7640301

Rigid - Flexible PVC.

Frame accessories

**PROFILE FOR SMOOTH TUBE**



1. PVC flexible area
2. Panel
3. Upper profil
4. Down profil
5. Smooth tube

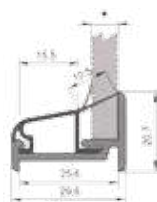

★	L	Kg	COD.
5<★>8	3	0,27	7640315

Magnetic door stop.  
Reinforced polyamide + regulable magnet.

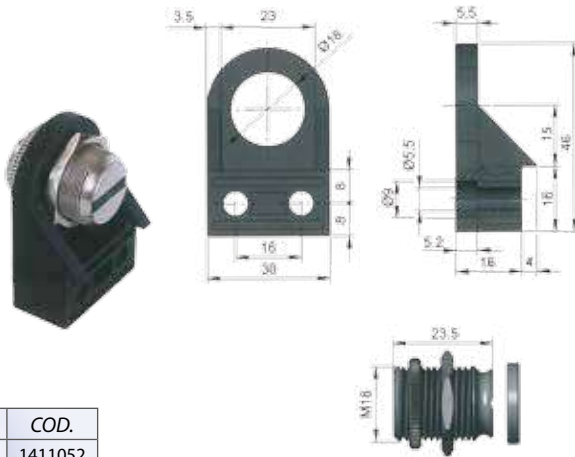

Kg	COD.
0,06	1411052

Reinforced polyamide.

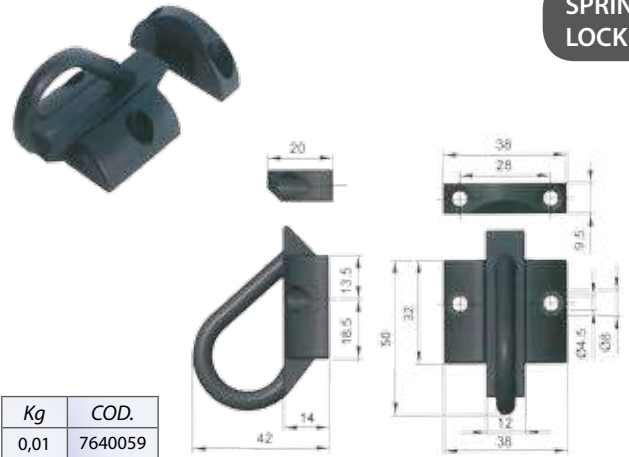

**SPRING  
LOCK**

Kg	COD.
0,01	7640059

Panel locking attachment.  
Reinforced polyamide.

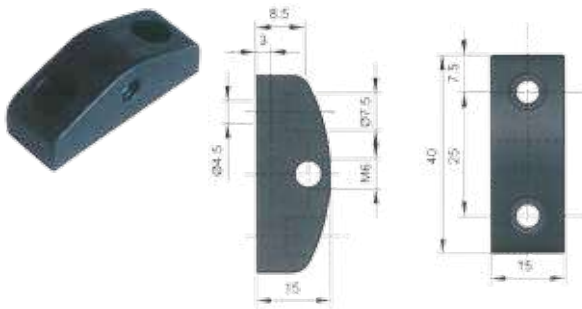

Kg	COD.
0,01	7640060

Reinforced polyamide, fastener in stainless steel.

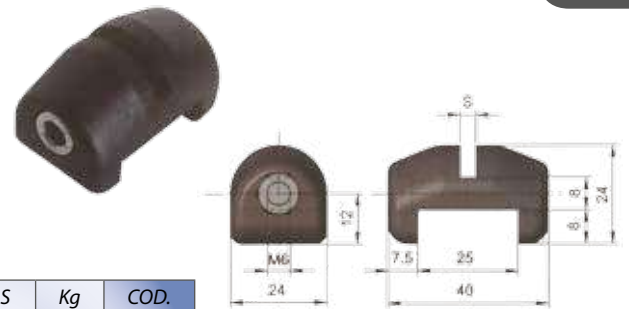

**PANEL  
CLAMP**

S	Kg	COD.
4	0,03	7640051
5	0,03	7640052
6	0,03	7640053

Reinforced polyamide.



**STOP FOR  
HINGED  
DOORS**

Kg	COD.
0,01	7640501

## Handles

Reinforced polyamide.



B	W	C	ØD	H	F	Kg	COD.

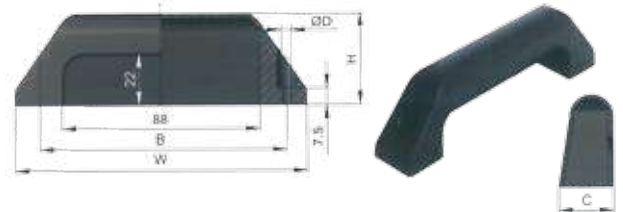

B	W	C	ØD	H	M	Kg	COD.
112	130	24	Ø6,3	41	-	0,06	7809410

Frame accessories/  
Handles

Reinforced polyamide, bush in zinc.



B	W	C	ØD	H	M	Kg	COD.
140	170	25	-	57	M8	0,17	7809210

Reinforced polyamide.



B	W	C	ØD	H	M	Kg	COD.
133	200	30	-	48	M8	0,11	7809310

**Hinges**

Reinforced polyamide, pin in zinc plated steel.

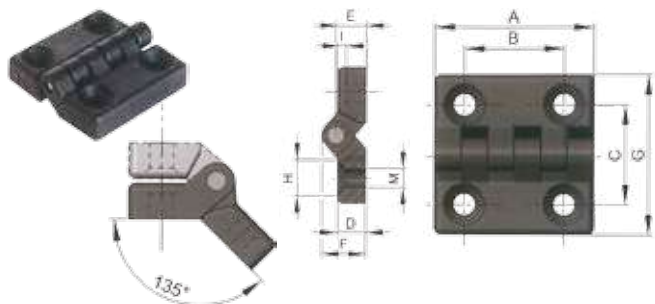

A	B	C	D	E	F	G	H	I	M	Kg	COD.
48	30	30	10	10	15	48	Ø13,5	3	Ø6,5	0,03	7810129
64	40	40	13	13	19	64	Ø13,5	3	Ø6,5	0,06	7810130
96	60	63	16	17	24	96	Ø16	4,6	Ø8	0,15	7810131

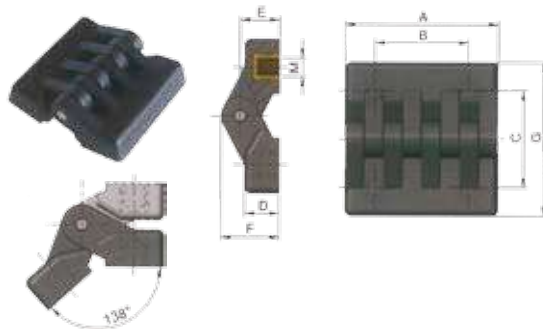

A	B	C	D	E	F	G	H	I	M	Kg	COD.
49	30	32	11	13	19	49	-	-	M5	0,06	7640208
49	30	32	11	13	19	49	-	-	M6	0,06	7640209

Reinforced polyamide, pin in stainless steel.

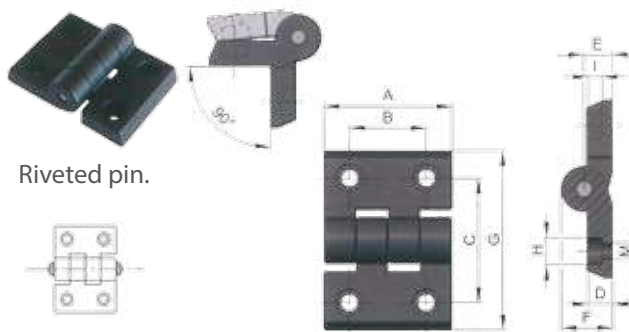

★ Reinforced

A	B	C	D	E	F	G	H	I	M	Kg	COD.
50	30	46	10	11	20	70	Ø10,5	6	Ø6,5	0,04	7810210
50*	30	46	10	11	20	70	Ø10,5	6	Ø6,5	0,04	7810211
50	30	46	10	11	20	70	Ø13,5	6	Ø8,5	0,04	7810212

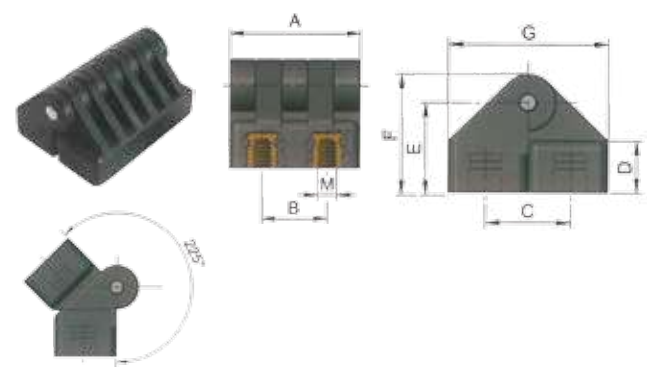

A	B	C	D	E	F	G	H	I	M	Kg	COD.
30	15	18	11	19	25	36	-	-	M5	0,04	7810110
54	30	21	13	22	29	42	-	-	M6	0,05	7810111
78	42	31	16	29	40	62	-	-	M8	0,06	7810112



A	B	C	D	E	F	G	H	I	M	Kg	COD.
102	72,5	49,5	11,5	10,5	19	80	Ø10,5	6	Ø6,5	0,10	7810220
102	72,5	49,5	11,5	10,5	19	80	Ø13,5	8	Ø8,5	0,10	7810221

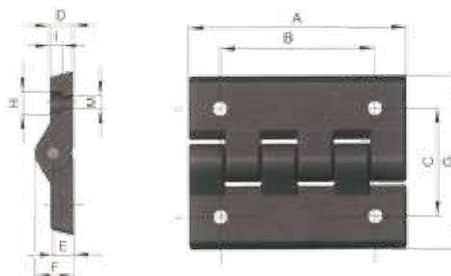



Head and fastener in stainless steel, tub in metrakilate.

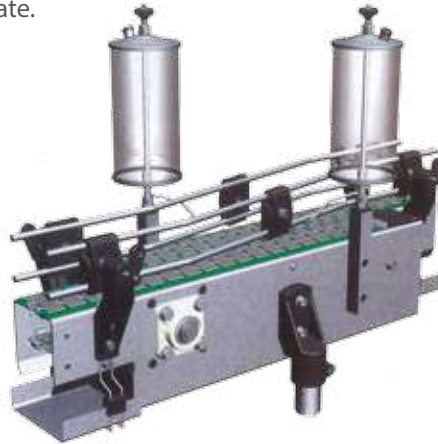

**REGULATE  
GREASER**

Liters	L	Kg	COD.
1'5	275	0,90	8417387
2'5	375	1,00	8417389
3'5	475	1,20	8417392

Greaser regulation by air intake-reduction.

## Guides for bottling and packaging

**FLAT  
GUIDE**

UHMW 1000 "DESLIDUR" Polyethylene.

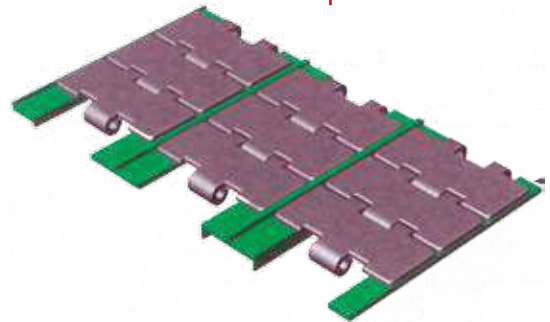
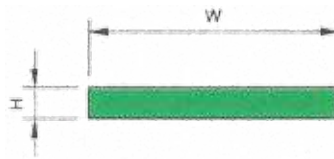

Standard Length

COLOUR	H	W									
		15	20	25	30	35	40	45	50	60	70
Green	3	P20100	P20101	P20102	P20103	P20104	P20105	P20106	P20107	P20109	P20111
Black	3	P30100	P30101	P30102	P30103	P30104	P30105	P30106	P30107	-	-
Kg/m	-	0,05	0,06	0,07	0,09	0,10	0,11	0,13	0,14	0,17	0,20
Green	5	P20120	P20121	P20122	P20123	P20124	P20125	P20126	P20127	-	-
Black	5	P30120	P30121	P30122	P30123	P30124	P30125	P30126	P30127	-	-
Kg/m	-	0,07	0,10	0,12	0,14	0,17	0,19	0,21	0,24	-	-



COLOUR	W	H	C	I	A	h	L	Kg/m	COD.
Green	20	10,5	14,5	3	-	-	50	0,11	P20269
Green	25	10,5	20	3	-	-	50	0,12	P20274
Black									P30274

COLOUR	W	H	C	I	A	h	L	Kg/m	COD.
Green	20	9	13	3	2,5	2,5	50	0,12	P20275
Black									P30275
Green	25	9	13	3	2,5	2,5	50	0,17	P20271
Black									P30271

COLOUR	W	H	C	I	A	h	L	Kg/m	COD.
Green	40	10,3	20	3	-	-	50	0,16	P20282
Black									P30282

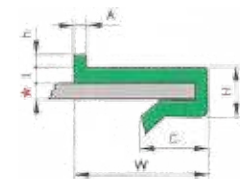
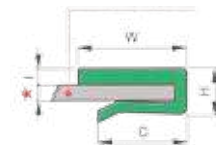

**PROFILE  
SECTION  
"P"**

Regulate greaser/  
Guides for bottling and packaging.

Wear strip to be used with plate width of 1.5 to 3 mm.

UHMW 1000  
"DESLIDUR"  
Polyethylene.

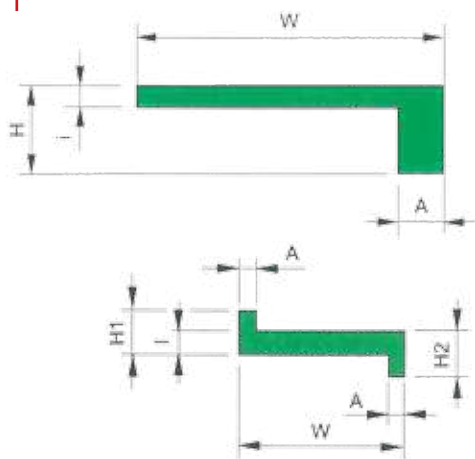

COLOUR	C	W	H	i	A	L	Kg/m	COD.
Green	L	20	5,5	3	2	50	0,06	P20254
Black								P30254
Green	L/53	53	6	3	2	50	0,16	P20255
Black								P30255
Green	L/23	23	7	4	4,8	50	0,11	P20256
Green	L/41	41	12	3	6	2	0,17	P20257L2
Black	L/20	10	5,5	3	2,5	50	0,07	P20258

COLOUR	C	W	H1	H2	I	A	L	Kg/m	COD.
Green	Z	20	5,5	5,5	3	2	50	0,07	P20250
Black									P30250
Green	Z/23	23	9	7	4	3	50	0,12	P20253
Black									P30253

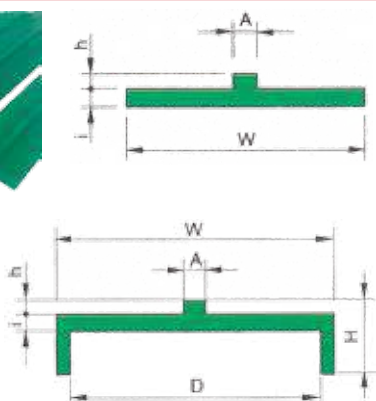

COLOUR	C	W	h	i	D	H	A	L	Kg/m	COD.
Green	T	40	2,5	3	-	-	4	50	0,11	P20260
Black										P30260

COLOUR	C	W	h	i	D	H	A	L	Kg/m	COD.
Green	DZ/36	40	3	3	36	9	4	50	0,13	P20262
Black										P30262
Green	DZ/32	44	2,5	3	32	8	4	50	0,16	P20264
Black										P30264
Green	DZ/41	46	2,5	3	41	11,5	4	50	0,17	P20266
Black										P30266
Green	DZ/31	43	3	4	31	15	3	50	0,21	P20268
Black										P30268

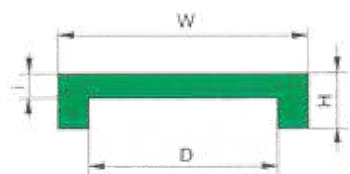

COLOUR	C	W	h	i	D	H	A	L	Kg/m	COD.
Green	DL/31	31	-	4	21	9	-	50	0,17	P20263
Black										P30263
Green	DL/31	41	-	4	31	9	-	50	0,17	P20265
Black										P30265
Green	DL/21	41	-	3	31	7	-	50	0,17	P20267
Black										P30267
Green	DL/37	42	-	4	36,5	7	-	50	0,17	P20272
Green	DL/24	34	-	7	24	15	-	2	0,32	P20296L2
Green	DL/41	45	-	3	40,5	9	-	50	0,16	P20297
Green	DL/29	39	-	5	29	18	-	2	0,33	P20298L2

Polyethylene UHMW 1000 "DESLIDUR" guide as in the table.

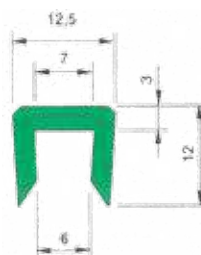

COLOUR	L	Kg/m	COD.
White	50	0,08	P10286
Green	50	0,08	P20286

Wear strip to be used with plate width of 5 to 6 mm.

**SECTION  
"U" GUIDE**

Polyethylene UHMW 1000 "DESLIDUR" guide as in the table.

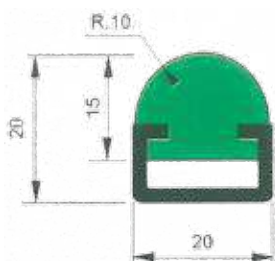

COLOUR	GUIDE	L	Kg/m	COD.

**SECTION  
"MC" GUIDE**

UHMW 1000 "DESLIDUR" Polyethylene.

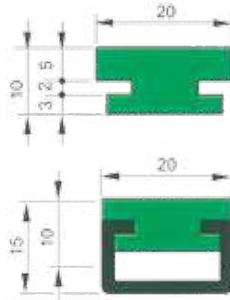

COLOUR	GUIDE	L	Kg/m	COD.
Green	-	50	0,16	P20352

COLOUR	GUIDE	L	Kg/m	COD.
Green	C 2010 SS	2	0,65	PSS20352L2
		3		PSS20352L3
Green	C 2010	2	0,65	PZN20352L2
		3		PZN20352L3

SECTION  
"H" GUIDE

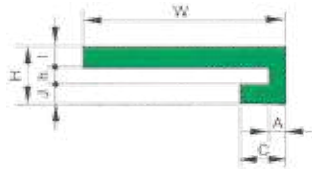

COLOUR	W	H	I	J	C	h	A	L	Kg/m	COD.
Green	23	10	4	3	11	3	3	2	0,11	P20312
Green	35	10	3,6	3,6	8	2,8	3	2	0,14	P20311
Green	40	8	3	2	25	3	10	2	0,19	P20310
Green	45	14	3	2,5	10	8,5	4	2	0,19	P20373

SECTION  
"L" GUIDE

UHMW 1000 "DESLIDUR" Polyethylene.



Metallic plate.

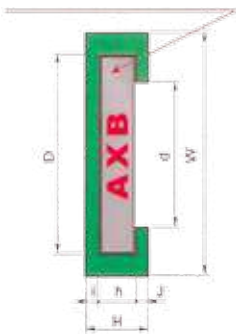

COLOUR	For steel A X B	W	H	i	h	J	D	d	L	Kg/m	COD.
Green	20 3	30	12	3	3,5	5,5	21	12	2	0,22	P20364L2
Green	20 5	30	12	3,5	5,2	3,3	20,5	12	2	0,17	P20365
Green	30 3	40	10	3,5	3,5	3	30,5	23	50	0,19	P20370
Green	40 4	50	10,5	3	4,5	3	41	29	50	0,24	P20367
Green	40 6	50	12	3	6,5	2,5	40,3	28,5	2	0,24	P20369L2
Green	40 8	50	14	3	8,3	2,7	41	30	50	0,26	P20371
Green	40 10	50	16	3	10,3	2,7	41	30	2	0,27	P20372
Green	50 6	60	12	3	6,5	2,5	51	35	50	0,28	P20374
Black	80 5	90	12	4	5,5	2,5	81	70	2	0,42	P30392L2

SECTION  
"C" GUIDE

Other sizes on request.

UHMW 1000 "DESLIDUR" Polyethylene.

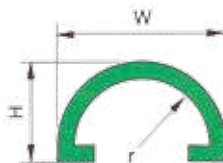

COLOUR		W	H	r	L	Kg/m	COD.
White	Clip MC 10 mm - 3/8"	25	15	10	50	0,10	P10386
Green						0,10	P20386
White	Clip MC 8 mm - 5/16"	20	13	8	50	0,09	P10388
Green						0,09	P20388

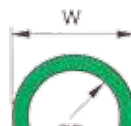

COLOUR		W	ØD	L	Kg/m	COD.
White	Clip Ø 12 - 1/2"	16,5	12	50	0,08	P10400
Green				50	0,08	P20400
White	Clip Ø 10 - 3/8"	13,8	10	50	0,07	P10402
Green				50	0,07	P20402
White	Clip Ø 8 - 1/2"	13	8	50	0,06	P10404
Green				50	0,06	P20404

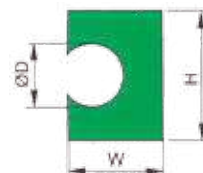

COLOUR	ØD	H	W	L	Kg/m	COD.
Green	8	20	14	2	0,21	R08
Green	10	22	16	2	0,25	R10
Green	12	24	18	2	0,29	R12



COLOUR	ØD	H	W	L	Kg/m	COD.
Green	6	20	14	2	0,21	MCH06
Green	8	20	14	2	0,19	MCH08
Green	10	22	16	2	0,22	MCH10
Green	12	24	18	2	0,25	MCH12

UHMW 1000 "DESLIDUR" Polyethylene.

**BOTTLE GUIDE**

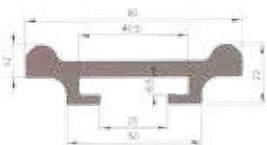

COLOUR	L	Kg/m	COD.
Black	2	0,60	P30389



COLOUR	L	Kg/m	COD.
Black	2	0,73	P30382



COLOUR	L	Kg/m	COD.
Green	2	0,76	P20384

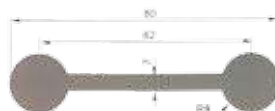

COLOUR	L	Kg/m	COD.

*Profiles of bevel channel*

UHMW 1000 "DESLIDUR" Polyethylene.

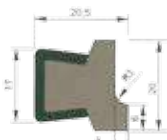
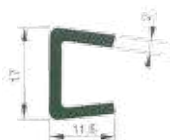

COLOUR	GUIDE	L	Kg/m	COD.
White	SS	3	0,71	CSS 10022
Black				CSS 30022



COLOUR	GUIDE	L	Kg/m	COD.
White	SS	3	0,67	CSS 10005
Black				CSS 30005

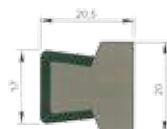

COLOUR	GUIDE	L	Kg/m	COD.
White	SS	3	0,74	CSS 10020
Black				CSS 30020

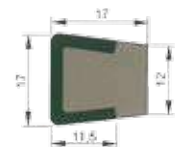

COLOUR	GUIDE	L	Kg/m	COD.
White	SS	3	0,69	CSS 10010
Black				CSS 30010

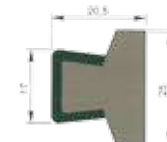

COLOUR	GUIDE	L	Kg/m	COD.
White	SS	3	0,78	CSS 10025
Black				CSS 30025

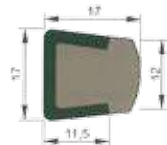

COLOUR	GUIDE	L	Kg/m	COD.
White	SS	3	0,69	CSS 10015
Black				CSS 30015

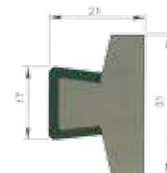

COLOUR	GUIDE	L	Kg/m	COD.
White	SS	3	0,82	CSS 10030
Black				CSS 30030

Stainless steel



COLOUR	GUIDE	H	L	Kg/m	COD.
White	SS	40	3	0,88	CSS 10035
Black					CSS 30035
White	SS	50	2	0,95	CSS 10037L2
Black					CSS 30037L2
White	SS	60	2	1,02	CSS 10039L2
Black					CSS 30039L2

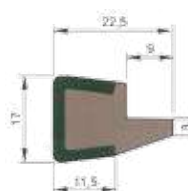

COLOUR	GUIDE	L	Kg/m	COD.
White	SS	3	0,71	CSS 10045
Black				CSS 30045

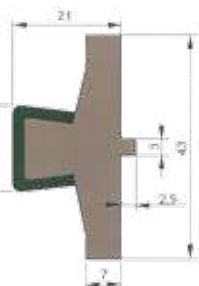

COLOUR	GUIDE	L	Kg/m	COD.
White	SS	2	0,89	CSS 10040L2
Black				CSS 30040L2

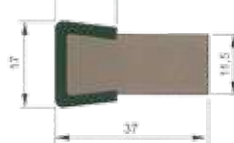

COLOUR	GUIDE	L	Kg/m	COD.
White	SS	3	0,89	CSS 10060
Black				CSS 30060

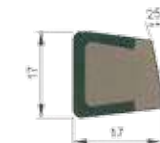

COLOUR	GUIDE	L	Kg/m	COD.
White	SS	3	0,65	CSS 10046
Black				CSS 30046

Stainless steel

UHMW 1000 "DESLIDUR" Polyethylene.

CHAIN  
PROFILES

Chain ISO	Pitch	W	H	A	h	L	Kg/m	COD.
06 B1	3/8"	15	10	5,4	1,5	2	0,13	S-1
08 B1	1/2"	20	10	7,4	2,2	2	0,16	S-2
08 B1	1/2"	20	15	7,4	2,2	2	0,26	S-215
10 B1	5/8"	20	10	9,2	2,6	2	0,16	S-3
10 B1	5/8"	20	15	9,2	2,6	2	0,26	S-315
12 B1	3/4"	25	10	11,3	2,4	2	0,21	S-4
12 B1	3/4"	25	15	11,3	2,4	2	0,32	S-415
16 B1	1"	40	15	16,5	3,5	2	0,47	S-5
16 B1	1"	40	20	16,5	3,5	2	0,66	S-520
20 B1	1 1/4"	45	15	19	4,3	2	0,53	S-6
20 B1	1 1/4"	45	20	19	4,3	2	0,72	S-620
24 B1	1 1/2"	60	15	24,6	5,6	2	0,78	S-7
28 B1	1 3/4"	75	20	30	6,9	2	1,13	S-8
32 B1	2"	85	20	30	7,8	2	1,21	S-9

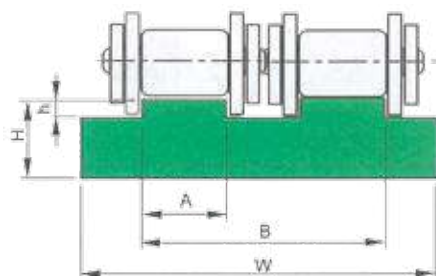
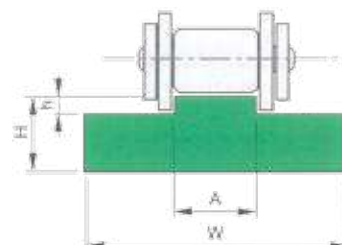

Chain ISO	Pitch	W	H	A	h	B	L	Kg/m	COD.
06 B2	3/8"	25	10	5,4	1,5	16	2	0,23	D-1
08 B2	1/2"	35	10	7,4	2,2	21	2	0,31	D-2
10 B2	5/8"	40	10	9,2	2,6	26	2	0,34	D-3
10 B2	5/8"	40	15	9,2	2,6	26	2	0,52	D-315
12 B2	3/4"	45	10	11,3	2,4	31	2	0,40	D-4
12 B2	3/4"	45	15	11,3	2,4	31	2	0,60	D-415

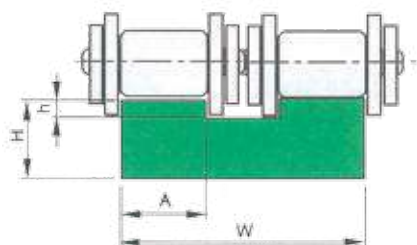

Chain ISO	Pitch	W	H	A	h	L	Kg/m	COD.
16 B2	1"	48	15	16,5	3,5	2	0,86	D-5
16 B2	1"	48	20	16,5	3,5	2	1,16	D-520
20 B2	1 1/4"	55	15	19	4,3	2	0,91	D-6
20 B2	1 1/4"	55	20	19	4,3	2	1,23	D-620
24 B2	1 1/2"	72	20	24,6	5,6	2	1,50	D-7
28 B2	1 3/4"	89	20	30	6,9	2	1,79	D-8
32 B2	2"	89	20	30	7,8	2	1,75	D-9

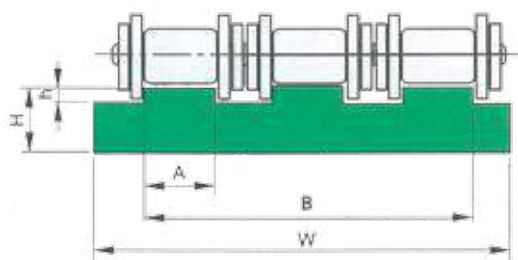

Chain ISO	Pitch	W	H	A	h	B	L	Kg/m	COD.
06 B3	3/8"	35	10	5,4	1,5	25,9	2	0,31	T-1
08 B3	1/2"	45	10	7,4	2,2	35,3	2	0,38	T-2
08 B3	1/2"	45	15	7,4	2,2	35,3	2	0,59	T-2.15
08 B3	1/2"	45	20	7,4	2,2	35,3	2	0,81	T-2.20
10 B3	5/8"	55	10	9,2	2,6	42,5	2	0,45	T-3
12 B3	3/4"	65	10	11,3	2,4	50,3	2	0,55	T-4
16 B3	1"	95	15	16,5	3,5	80,3	2	1,17	T-5

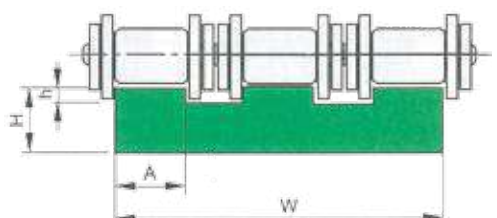

Chain ISO	Pitch	W	H	A	h	L	Kg/m	COD.
20 B3	1 1/4"	92	15	19,0	4,3	2	1,30	T-6
24 B3	1 1/2"	121	20	24,6	5,6	2	2,25	T-7
28 B3	1 3/4"	149	25	30,0	6,9	2	3,52	T-8
32 B3	2"	149	30	30,0	7,8	2	4,26	T-9

Roller chain guides

UHMW 1000 "DESLIDUR" Polyethylene.

**CHAIN  
PROFILES**

Chain ISO	Pitch	W	H	C	h	J	d	L	Kg/m	COD.
06 B	3/8"	20	15	9,2	4,2	2,8	4	2	0,26	U-1
08 B	1/2"	25	15	12,7	4,8	3,5	5	2	0,31	U-2
10 B	5/8"	25	15	15,2	5,1	3,6	6	2	0,29	U-3
12 B	3/4"	25	20	16,7	5,7	3,9	7	2	0,43	U-4
16 B	1"	35	25	24,4	10	8,4	9	2	0,62	U-5

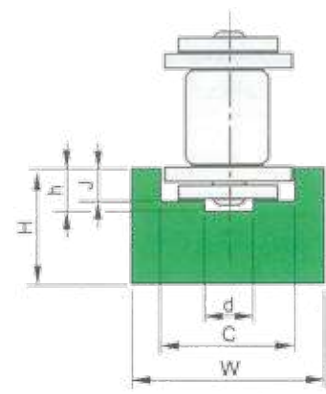

Chain ISO	Pitch	GUIDE	W	H	K	h	J	d	L	Kg/m	COD.
06 B	3/8"	C 2010	20	10	15	4,2	2,8	4	2	0,72	UCG-1
		C 2010 SS									UCG-1.SS
08 B	1/2"	C 2812	25	15	22	4,8	3,5	5	2	1,14	UCG-2
		C 2812 SS									UCG-2.SS
10 B	5/8"	C 2812	25	15	22	5,1	3,6	6	2	1,13	UCG-3
		C 2812 SS									UCG-3.SS
12 B	3/4"	C 2812	25	20	27	5,7	3,9	7	2	1,27	UCG-4
		C 2812 SS									UCG-4.SS
16 B	1"	C 3818	35	25	33	10	8,4	9	2	2,03	UCG-5
		C 3818 SS									UCG-5.SS

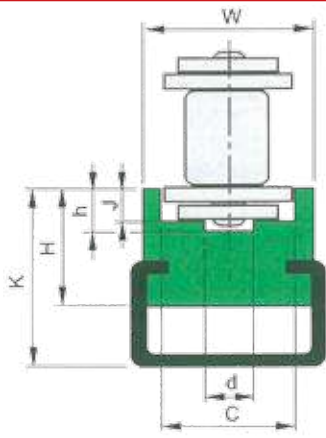

Chain ISO	Pitch	GUIDE	W	H	H1	H2	A	K	L	Kg/m	COD.
06 B1	3/8"	C 2010	20	25	30	17	14,5	27	2	0,90	2PCG-1
		C 2010 SS									2PCG-1.SS
08 B1	1/2"	C 2010	20	28	34	18	16,5	30	2	0,96	2PCG-2
		C 2010 SS									2PCG-2.SS
10 B1	5/8"	C 2010	20	33	41	21	15,5	36	2	1,12	2PCG-3
		C 2010 SS									2PCG-3.SS
12 B1	3/4"	C 2812	28	37	46,5	24	18,6	41	2	1,70	2PCG-4
		C 2812 SS									2PCG-4.SS
16 B1	1"	C 3818	38	51	62	34	25	54	2	3,10	2PCG-5
		C 3818 SS									2PCG-5.SS

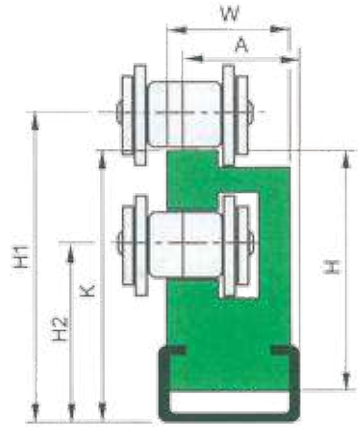

Chain ISO	Pitch	GUIDE	W	H	K	h	A	L	Kg/m	COD.
06 B1	3/8"	C 2010	20	15	17	1,5	5,4	2	0,62	TCG-1
		C 2010 SS								TCG-1.SS
08 B1	1/2"	C 2010	20	15	17	2,2	7,4	2	0,69	TCG-2
		C 2010 SS								TCG-2.SS
10 B1	5/8"	C 2010	20	15	17	2,6	9,2	2	0,70	TCG-3
		C 2010 SS								TCG-3.SS
12 B1	3/4"	C 2812	28	15	18	2,4	11,3	2	1,17	TCG-4
		C 2812 SS								TCG-4.SS
16 B1	1"	C 2812	28	20	24	3,5	16,5	2	2,24	TCG-5
		C 2812 SS								TCG-5.SS
16 B1	1"	C 2812	28	15	18	3,5	16,5	2	1,25	TCG-5R
		C 2812 SS								TCG-5R.SS
20 B1	1 1/4"	C 3818	38	25	30	4,3	19,0	2	2,305	TCG-6
		C 3818 SS								TCG-6.SS
24 B1	1 1/2"	C 3818	38	25	30	5,6	24,6	2	2,390	TCG-7
		C 3818 SS								TCG-7.SS
28 B1	1 3/8"	C 3818	38	25	30	6,9	30	2	2,410	TCG-8
		C 3818 SS								TCG-8.SS
32 B1	2"	C 3818	38	25	30	7,8	30	2	2,480	TCG-9
		C 3818 SS								TCG-9.SS

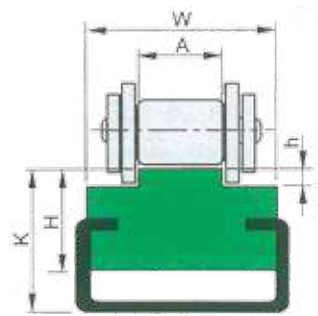

Roller chain guides

UHMW 1000 "DESLIDUR" Polyethylene.

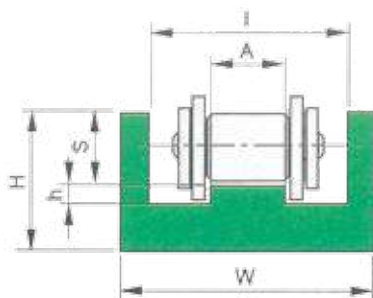

Chain ISO	Pitch	W	H	I	h	A	S	L	Kg/m	COD.
06 B1	3/8"	25	10	15	1,5	5,4	4,4	2	0,17	UC-1
08 B1	1/2"	30	15	20	2,2	7,4	7,2	2	0,27	UC-2
10 B1	5/8"	33	20	23	2,6	9,2	9,5	2	0,40	UC-3
12 B1	3/4"	38	20	28	2,4	11,3	11,1	2	0,41	UC-4
16 B1	1"	51	25	41	3,5	16,5	16,5	2	0,51	UC-5
20 B1	1 1/4"	56	30	46	4,3	19	20,7	2	0,72	UC-6

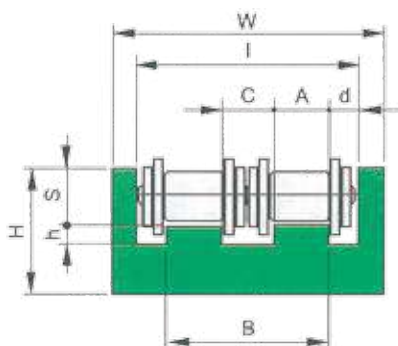

Chain ISO	Pitch	W	H	I	h	A	S	B	C	d	L	Kg/m	COD.
06 B2	3/8"	36	15	26	1,5	5,4	4,4	16	5,2	5	2	0,39	UCD-1
08 B2	1/2"	45	20	35	2,2	7,4	7,2	21	6,2	7	2	0,62	UCD-2
10 B2	5/8"	50	25	40	2,6	9,2	9,5	26	7,6	7	2	0,82	UCD-3
12 B2	3/4"	56	25	46	2,4	11,3	11,1	31	8,4	7,5	2	0,81	UCD-4
16 B2	1"	85	30	75	3,5	16,5	16,5	48,4	15,4	13,3	2	1,20	UCD-5

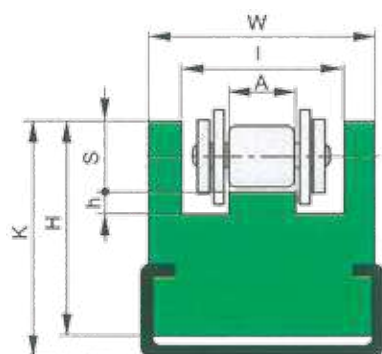

Chain ISO	Pitch	GUIDE	W	H	K	I	h	A	S	L	Kg/m	COD.
06 B1	3/8"	C 2010	25	15	18	15	1,5	5,4	4,4	2	0,76	UCCG-1
		C 2010 SS										UCCG-1.SS
08 B1	1/2"	C 2812	30	25	27	20	2,2	7,4	7,2	2	1,10	UCCG-2
		C 2812 SS										UCCG-2.SS
10 B1	5/8"	C 2812	33	30	32	23	2,6	9,2	9,5	2	1,30	UCCG-3
		C 2812 SS										UCCG-3.SS
12 B1	3/4"	C 3818	38	35	40	28	2,4	11,3	11,1	2	2,33	UCCG-4
		C 3818 SS										UCCG-4.SS
16 B1	1"	C 3818	51	40	45	41	3,5	16,5	16,5	2	2,44	UCCG-5
		C 3818 SS										UCCG-5.SS

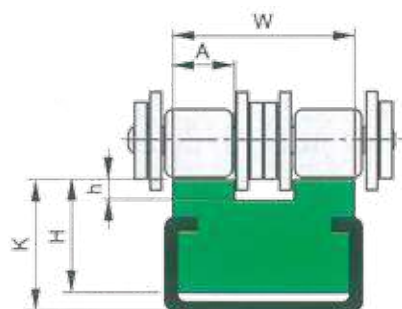

Chain ISO	Pitch	GUIDE	W	H	K	h	A	L	Kg/m	COD.
06 B2	3/8"	C 2010	20	10	15	1,5	5,4	2	0,61	TCGD-1
		C 2010 SS								TCGD-1.SS
08 B2	1/2"	C 2010	21,5	15	17	2,2	7,4	2	0,71	TCGD-2
		C 2010 SS								TCGD-2.SS
10 B2	5/8"	C 2812	28	15	17	2,6	9,2	2	1,16	TCGD-3
		C 2812 SS								TCGD-3.SS
12 B2	3/4"	C 2812	31	15	18	2,4	11,3	2	1,20	TCGD-4
		C 2812 SS								TCGD-4.SS

UHMW 1000 "DESLIDUR" Polyethylene.

**CHAIN  
PROFILES**

Chain ISO	Pitch	W	H	C	h	I	J	d	D	L	Kg/m	COD.
06 B	3/8"	20	25	9,3	10	5,6	8,7	4	6,6	2	0,41	GH-1
08 B	1/2"	24	30	12,8	12,7	7,6	11,5	5	8,7	2	0,56	GH-2
10 B	5/8"	30	35	15,4	14,8	9,5	16,5	6	10,4	2	0,83	GH-3
12 B	3/4"	40	35	16,9	17,5	11,5	15,9	7	12,3	2	1,11	GH-4
16 B	1"	40	45	24,4	28,2	15,9	25,7	9	16,2	2	1,23	GH-5
20 B	1 1/4"	50	50	27,5	31,2	19,4	29,3	11	19,3	2	1,73	GH-6
24 B	1 1/2"	60	60	36,5	40,1	25,2	38,2	16	25,7	2	2,33	GH-7
28 B	1 3/4"	70	70	41,5	48,9	30,8	46,9	17	28,3	2	3,17	GH-8
32 B	2"	75	75	44,5	53,0	30,8	47,3	19	29,6	2	3,26	GH-9

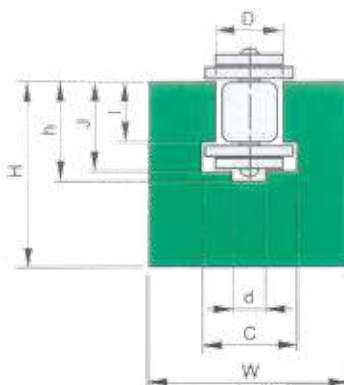

Chain ISO	Pitch	GUIDE	W	K	I	D	L	Kg/m	COD.
06 B	3/8"	C 3024	30	24	5,6	6,6	2	1,37	GHCG-1
		C 3024 SS							GHCG-1.SS
08 B	1/2"	C 3024	30	24	7,6	8,7	2	1,35	GHCG-2
		C 3024 SS							GHCG-2.SS
08 B	1/2"	C 2816	28	16	7,6	8,7	2	1,26	GHCG-2E
		C 2816 SS							GHCG-2E.SS
10 B	5/8"	C 3024	30	24	9,3	10,4	2	1,30	GHCG-3
		C 3024 SS							GHCG-3.SS
12 B	3/4"	C 3024	30	24	11,5	12,3	2	1,26	GHCG-4
		C 3024 SS							GHCG-4.SS
16 B	1"	C 4540	45	40	15,9	16,2	2	2,93	GHCG-5
		C 4540 SS							GHCG-5.SS

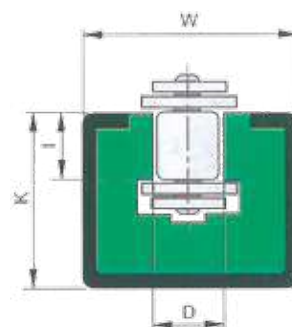

Chain ISO	Pitch	GUIDE	W	H	K	I	J	h	d	D	C	L	Kg/m	COD.
06 B	3/8"	C 2010	20	17,5	21	5,6	8,7	9,9	4	6,6	9,3	2	0,62	GHLCG-1
		C 2010 SS												GHLCG-1.SS
08 B	1/2"	C 2812	28	27,5	32	7,6	11,5	12,7	5	8,7	12,8	2	1,45	GHLCG-2
		C 2812 SS												GHLCG-2.SS
10 B	5/8"	C 2812	28	27,5	32	9,3	13,5	14,8	6	10,4	15,4	2	1,40	GHLCG-3
		C 2812 SS												GHLCG-3.SS
12 B	3/4"	C 3818	38	34,0	43	11,5	15,9	17,5	7	12,3	16,9	2	1,71	GHLCG-4
		C 3818 SS												GHLCG-4.SS
16 B	1"	C 3818	38	40	50	15,9	25,7	28,2	9	16,2	24,4	2	1,60	GHLCG-5
		C 3818 SS												GHLCG-5.SS
20 B	1 1/4"	C 6020	60	45	55	19,4	29,3	31,2	11	19,3	27,5	2	4,80	GHLCG-6
		C 6020 SS												GHLCG-6.SS
24 B	1 1/2"	C 6020	60	55	65	25,2	38,2	40,1	16	25,7	36,5	2	5,00	GHLCG-7
		C 6020 SS												GHLCG-7.SS
28 B	1 3/4"	C 6020	70	70	80	30,8	46,9	48,9	17	28,3	41,5	2	6,20	GHLCG-8
		C 6020 SS												GHLCG-8.SS
32 B	2"	C 6020	70	70	80	30,8	47,3	53,0	19	29,6	44,5	2	6,20	GHLCG-9
		C 6020 SS												GHLCG-9.SS

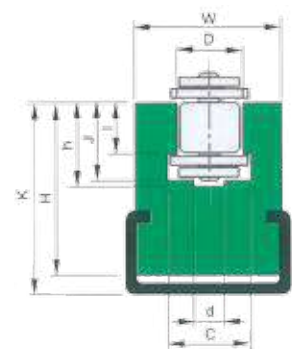

Roller chain guides

Chain ISO	Pitch	GUIDE	W	K	L	I	J	h	d	D	L	Kg/m	COD.
06 B	3/8"	C 5325	31	25	53	5,6	8,7	9,9	4	6,6	2	2,34	GHPCG-1
		C 5325 SS											GHPCG-1.SS
08 B	1/2"	C 5325	31	25	53	7,6	11,5	12,7	5	8,7	2	2,30	GHPCG-2
		C 5325 SS											GHPCG-2.SS
10 B	5/8"	C 5325	31	25	53	9,3	13,5	14,8	6	10,4	2	2,25	GHPCG-3
		C 5325 SS											GHPCG-3.SS
12 B	3/4"	C 5325	31	25	53	11,5	15,9	17,5	7	12,3	2	2,25	GHPCG-4
		C 5325 SS											GHPCG-4.SS

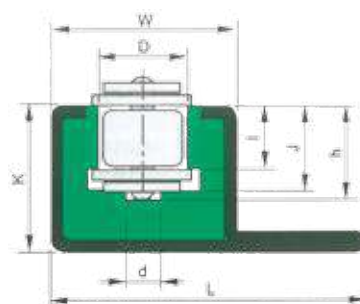



UHMW 1000 "DESLIDUR" Polyethylene.

Chain ISO	Pitch	GUIDE	W	K	L	I	J	h	d	D	L	Kg/m	COD.
06 B	3/8"	C 4731	25	31	47	5,6	8,7	9,9	4	6,6	2	2,15	GHGCG-1
		C 4731 SS											GHGCG-1.SS
08 B	1/2"	C 4731	25	31	47	7,6	11,5	12,7	5	8,7	2	2,15	GHGCG-2
		C 4731 SS											GHGCG-2.SS
10 B	5/8"	C 4731	25	31	47	9,3	13,5	14,8	6	10,4	2	2,10	GHGCG-3
		C 4731 SS											GHGCG-3.SS
12 B	3/4"	C 4731	25	31	47	11,5	15,9	17,5	7	12,3	2	2,06	GHGCG-4
		C 4731 SS											GHGCG-4.SS

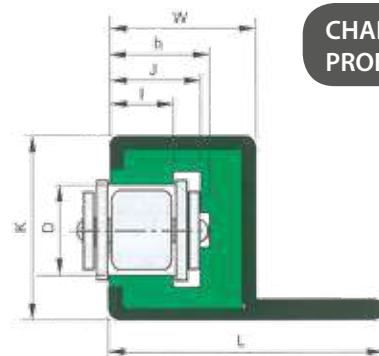

CHAIN PROFILES

# Flat belt, V-belt and cable guides

BELT PROFILES

GUIDE	W	K	H	h	L	Kg/m	COD.
C 2405	20	6	5	0,8	2	0,35	HCG 2006
C 2405 SS							HCG 2006.SS
C 2405	20	11	10	5,8	2	0,45	HCG 2011
C 2405 SS							HCG 2011.SS
C 2010	20	14	10	4	2	0,79	HCG 2014
C 2010 SS							HCG 2014.SS
C 2010	20	17	15	7	2	0,88	HCG 2017
C 2010 SS							HCG 2017.SS
C 2010	20	22	20	12	2	0,94	HCG 2022
C 2010 SS							HCG 2022.SS
C 2812	28	15	10	3	2	1,18	HCG 2815
C 2812 SS							HCG 2815.SS
C 2812	28	18	15	6	2	1,32	HCG 2818
C 2812 SS							HCG 2818.SS
C 2812	28	24	20	12	2	1,49	HCG 2824
C 2812 SS							HCG 2824.SS
C 3818	38	22	12	4	2	2,20	HCG 3822
C 3818 SS							HCG 3822.SS
C 3818	38	24	15	6	2	2,46	HCG 3824
C 3818 SS							HCG 3824.SS
C 3818	38	30	20	12	2	2,69	HCG 3830
C 3818 SS							HCG 3830.SS
C 6020	60	30	20	10	2	3,26	HCG 6030
C 6020 SS							HCG 6030.SS

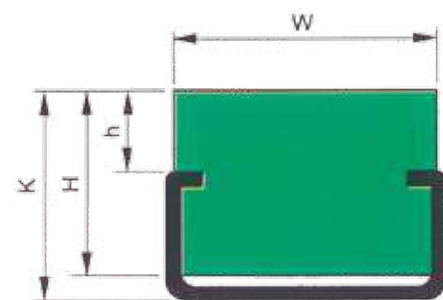

GUIDE	W	H	h	K	A	L	Kg/m	COD.
C 2010	20	15	3	17	6,5	2	0,79	CTCG 10 Z
C 2010 SS								CTCG 10 Z.SS
C 2010	20	15	5	17	8	2	0,78	CTCG 13 A
C 2010 SS								CTCG 13 A.SS
C 2812	25	20	5	24	10	2	1,35	CTCG 15 E
C 2812 SS								CTCG 15 E.SS
C 2812	30	20	8	24	10,5	2	1,44	CTCG 17 B
C 2812 SS								CTCG 17 B.SS
C 3818	38	25	11	32	13,5	2	2,26	CTCG 22 C
C 3818 SS								CTCG 22 C.SS
C 3818	40	30	13	35	19	2	2,57	CTCG 30 D
C 3818 SS								CTCG 30 D.SS

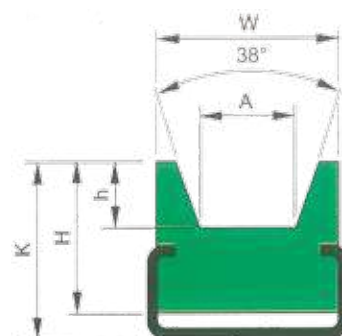

Roller chain guides/  
Flat belt, V-belt and cable guides

**STEEL  
PROFILES**



GUIDE	L	Kg/m	COD.
ZN	2	2,16	C 6020
SS	2	2,16	C 6020 SS

GUIDE	L	Kg/m	COD.
ZN	2	1,20	C 4731
SS	2	1,20	C 4731 SS

GUIDE	L	Kg/m	COD.
ZN	2	1,20	C 5325
SS	2	1,20	C 5325 SS

GUIDE	W	H	C	J	L	Kg/m	COD.
ZN	24	5,2	17,5	1	2	0,28	C 2405
SS					2	0,28	C 2405 SS
ZN	20	10	10	1,5	2	0,49	C 2010
SS					2	0,49	C 2010 SS
ZN	28	12	14	2	2	0,86	C 2812
SS					2	0,86	C 2812 SS
ZN	28	16	14	2,5	2	1,16	C 2816
SS					2	1,16	C 2816 SS
ZN	38	18	22	2,5	2	1,43	C 3818
SS					2	1,43	C 3818 SS
ZN	30	24	20	1,5	2	0,94	C 3024
SS					2	0,94	C 3024 SS
ZN	45	40	31	2	2	2,05	C 4540
SS					2	2,05	C 4540 SS

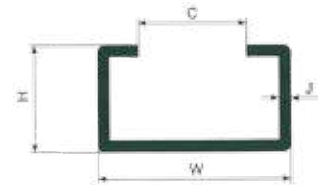
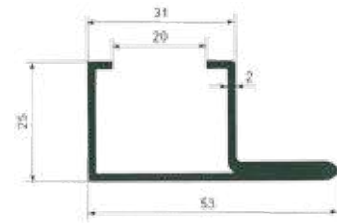
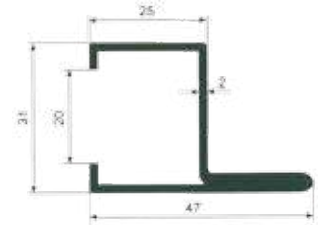
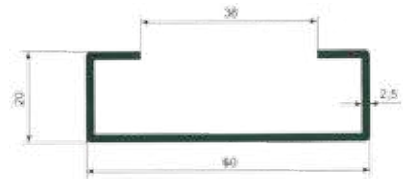

Standard length of Deslidur and steel profiles 2 mm. other lengths available on request.



Machine feet in base sizes from Ø40 to Ø125 are available in reinforced polyamide or stainless steel. Along with hinges or handles in different kinds of plastic materials or in stainless steel, we make it possible for you, to choose your preferred execution. The spindle material for the polyamide base feet can be supplied in either zinc plated or stainless steel.



## Fixed feet

Ø 50  
Part. 7

ø d	A mm	H mm	Spindle in zinc plated steel	Spindle in AISI 304	Max. static load N
			Code	Code	
M8	35	21	7/7370	7/7371	5000
	40	26	7/7372	7/7373	
	45	31	7/7374	7/7375	
	50	36	7/7376	7/7377	
	60	41	7/7378	7/7379	
M10	35	21	7/7380	7/7381	
	40	26	7/7382	7/7383	
	45	31	7/7384	7/7385	
	50	36	7/7386	7/7387	
	60	41	7/7388	7/7389	

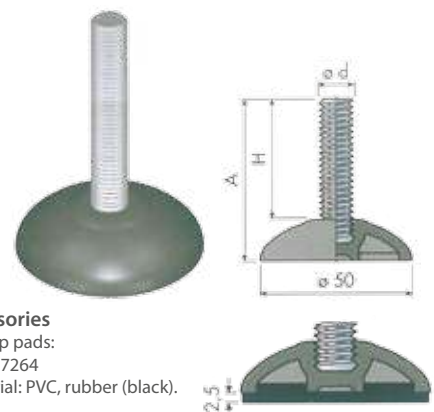

**Accessories**  
Anti-slip pads:  
- code: 7264  
- material: PVC, rubber (black).

Fixed feet

## Articulated feet - base in reinforced polyamide

Ø 40  
Part. 10

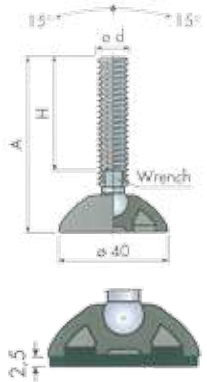

**Accessories**  
Anti-slip pads:  
- code: 7263  
- material: PVC, rubber (black).

ø d	A mm	H mm	Wrench mm	Spindle in zinc plated steel	Spindle in AISI 304	Max. static load N
				Code	Code	
M8	68	45	6	10/7390	10/7391	10000
	88	65	6	10/7392	10/7393	
M10	60	35	8	10/7000	10/7001	11000
	95	70	8	10/7002	10/7003	
	140	115	8	10/7004	10/7005	
M12	70	43	10	10/7006	10/7007	12000
	90	63	10	10/7008	10/7009	
	105	77	10	10/7394	10/7395	
	120	93	10	10/7010	10/7011	
	150	123	10	10/7012	10/7013	
M14	90	61	12	10/7014	10/7015	13000
	120	91	12	10/7016	10/7017	

Ø 50  
Part. 15

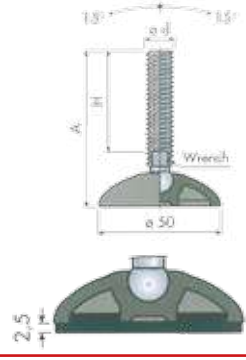

**Accessories**  
Anti-slip pads:  
- code: 7264  
- material: PVC, rubber (black).

ø d	A mm	H mm	Wrench mm	Spindle in zinc plated steel	Spindle in AISI 304	Max. static load N
				Code	Code	
M8	68	45	6	15/7396	15/7397	11000
	88	65	6	15/7398	15/7399	
M10	60	35	8	15/7018	15/7019	11000
	95	70	8	15/7020	15/7021	
	140	115	8	15/7022	15/7023	
M12	70	43	10	15/7024	15/7025	12000
	90	63	10	15/7026	15/7027	
	105	77	10	15/7400	15/7401	
	120	93	10	15/7028	15/7029	
	150	123	10	15/7030	15/7031	
M14	90	61	12	15/7032	15/7033	13000
	120	91	12	15/7034	15/7035	

Ø 60  
Part. 18

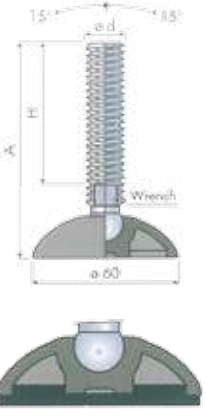

**Accessories**  
Anti-slip pads:  
- code: 7265  
- material: PVC, rubber (black).

ø d	A mm	H mm	Wrench mm	Spindle in zinc plated steel	Spindle in AISI 304	Max. static load N
				Code	Code	
M8	72	45	6	18/7402	18/7403	12000
	92	65	6	18/7404	18/7405	
M10	64	35	8	18/7036	18/7037	13000
	99	70	8	18/7038	18/7039	
	144	115	8	18/7040	18/7041	
M12	74	43	10	18/7042	18/7043	14000
	94	63	10	18/7044	18/7045	
	109	77	10	18/7406	18/7407	
	124	93	10	18/7046	18/7047	
	154	123	10	18/7048	18/7049	
M14	94	61	12	18/7050	18/7051	15000
	124	91	12	18/7052	18/7053	
M16	95	60	13	18/7054	18/7055	17000
	125	90	13	18/7408	18/7409	
	140	105	13	18/7056	18/7057	
	160	125	13	18/7058	18/7059	
	190	155	13	18/7410	18/7411	
	200	165	13	18/7060	18/7061	
M20	125	86	17	18/7062	18/7063	19000
	155	116	17	18/7064	18/7065	
	180	141	17	18/7066	18/7067	
	245	206	17	18/7068	18/7069	

Articulated feet

60X95  
Part. 27

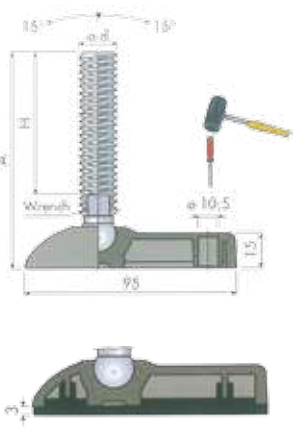

**Accessories**  
Anti-slip pads:  
- code: 7632  
- material: PVC, rubber (black).

ø d	A mm	H mm	Wrench mm	Spindle in zinc plated steel	Spindle in AISI 304	Max. static load N
				Code	Code	
M8	72	45	6	27/7412	27/7413	12000
	92	65	6	27/7414	27/7415	
M10	64	35	8	27/7416	27/7417	13000
	99	70	8	27/7418	27/7419	
	144	115	8	27/7420	27/7421	
M12	74	43	10	27/7422	27/7423	14000
	94	63	10	27/7424	27/7425	
	109	77	10	27/7426	27/7427	
	124	93	10	27/7428	27/7429	
	154	123	10	27/7430	27/7431	
M14	94	61	12	27/7432	27/7433	15000
	124	91	12	27/7434	27/7435	
M16	95	60	13	27/7436	27/7437	17000
	125	90	13	27/7438	27/7439	
	140	105	13	27/7440	27/7441	
	160	125	13	27/7442	27/7443	
	190	155	13	27/7444	27/7445	
	200	165	13	27/7446	27/7447	
M20	125	86	17	27/7448	27/7449	19000
	155	116	17	27/7450	27/7451	
	180	141	17	27/7452	27/7453	
	245	206	17	27/7454	27/7455	

# Articulated feet - base in reinforced polyamide

Ø 80  
Part. 25

ø d	A mm	H mm	Wrench mm	Spindle in zinc plated steel	Spindle in AISI 304	Max. static load N
				Code	Code	
M8	74	45	6	25/7456	25/7457	12000
	94	65	6	25/7458	25/7459	
M10	66	35	8	25/7070	25/7071	14000
	101	70	8	25/7072	25/7073	
	146	115	8	25/7074	25/7075	
M12	76	43	10	25/7076	25/7077	15000
	96	63	10	25/7078	25/7079	
	111	77	10	25/7460	25/7461	
	126	93	10	25/7080	25/7081	
M14	156	123	10	25/7082	25/7083	16000
	96	61	12	25/7084	25/7085	
	126	91	12	25/7086	25/7087	19000
	97	60	13	25/7088	25/7089	
M16	127	90	13	25/7462	25/7463	19000
	142	105	13	25/7090	25/7091	
	162	125	13	25/7092	25/7093	
	192	155	13	25/7464	25/7465	
	202	165	13	25/7094	25/7095	
M20	127	86	17	25/7096	25/7097	21000
	157	116	17	25/7098	25/7099	
	182	141	17	25/7100	25/7101	
	247	206	17	25/7102	25/7103	
M24	137	96	19	25/7466	25/7467	23000
	163	122	19	25/7104	25/7105	
	182	141	19	25/7468	25/7469	
	193	152	19	25/7106	25/7107	
	217	176	19	25/7470	25/7471	
	223	182	19	25/7108	25/7109	
341	300	19	25/7472	25/7473		

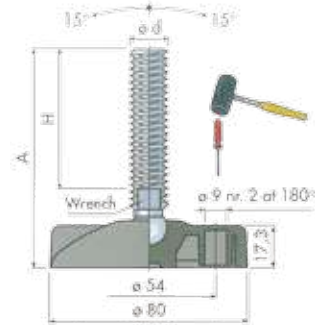

### Accessories

Anti-slip pads:  
- code: 7266  
- material: PVC, rubber (black).



ø d	A mm	H mm	Wrench mm	Spindle in zinc plated steel	Spindle in AISI 304	Max. static load N
				Code	Code	
M16	100	60	13	38/7110	38/7111	22000
	130	90	13	38/7474	38/7475	
	145	105	13	38/7112	38/7113	
	165	125	13	38/7114	38/7115	
	195	155	13	38/7476	38/7477	
	205	165	13	38/7116	38/7117	
M20	130	86	17	38/7118	38/7119	24000
	160	116	17	38/7120	38/7121	
	185	141	17	38/7122	38/7123	
	250	206	17	38/7124	38/7125	
M24	140	96	19	38/7478	38/7479	26000
	166	122	19	38/7126	38/7127	
	185	141	19	38/7480	38/7481	
	196	152	19	38/7128	38/7129	
	220	176	19	38/7482	38/7483	
	226	182	19	38/7130	38/7131	
344	300	19	38/7484	38/7485		

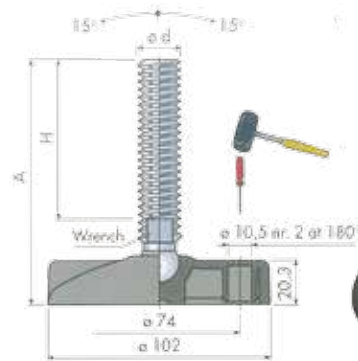

### Accessories

Anti-slip pads:  
- code: 7267  
- material: PVC, rubber (black).



Ø 102  
Part. 38

ø d	A mm	H mm	Wrench mm	Spindle in zinc plated steel	Spindle in AISI 304	Max. static load N
				Code	Code	
M16	104	60	13	45/7132	45/7133	25000
	134	90	13	45/7486	45/7487	
	149	105	13	45/7134	45/7135	
	169	125	13	45/7136	45/7137	
	199	155	13	45/7488	45/7489	
	209	165	13	45/7138	45/7139	
M20	134	86	17	45/7140	45/7141	27000
	164	116	17	45/7142	45/7143	
	189	141	17	45/7144	45/7145	
	254	206	17	45/7146	45/7147	
M24	144	96	19	45/7490	45/7491	29000
	170	122	19	45/7148	45/7149	
	189	141	19	45/7492	45/7493	
	200	152	19	45/7150	45/7151	
	224	176	19	45/7494	45/7495	
	230	182	19	45/7152	45/7153	
348	300	19	45/7496	45/7497		

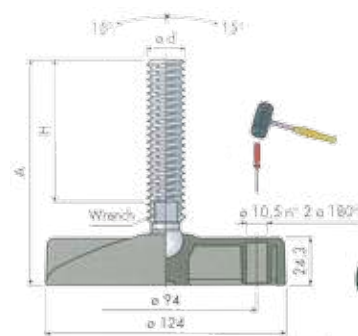

### Accessories

Anti-slip pads:  
- code: 7268  
- material: PVC, rubber (black).



Ø 124  
Part. 45

Articulated feet

**STAINLESS FEET**

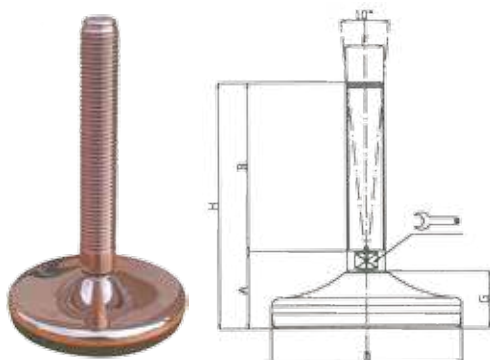

CODE	description	Main Dimension							Static load Newton
		A	B	D	CH	F	G	H1	
25100	M16X75	39,5	75	Ø100	13	M16	30	114,5	15000
25102	M16X100	39,5	100	Ø100	13	M16	30	139,5	15000
25104	M16X125	39,5	125	Ø100	13	M16	30	164,5	15000
25106	M16X150	39,5	150	Ø100	13	M16	30	189,5	15000
25108	M16X175	39,5	175	Ø100	13	M16	30	214,5	15000
25110	M16X200	39,5	200	Ø100	13	M16	30	239,5	15000
25120	M20X75	43	75	Ø100	17	M20	30	118	15000
25122	M20X100	43	100	Ø100	17	M20	30	143	15000
25124	M20X125	43	125	Ø100	17	M20	30	168	15000
25126	M20X150	43	150	Ø100	17	M20	30	193	15000
25128	M20X175	43	175	Ø100	17	M20	30	218	15000
25130	M20X200	43	200	Ø100	17	M20	30	243	15000
25132	M20X225	43	225	Ø100	17	M20	30	268	15000
25134	M20X250	43	250	Ø100	17	M20	30	293	15000
25150	M24x100	44	100	Ø100	20	M24	30	144	15000
25152	M24x125	44	125	Ø100	20	M24	30	169	15000
25154	M24x150	44	150	Ø100	20	M24	30	194	15000
25156	M24x175	44	175	Ø100	20	M24	30	219	15000
25158	M24x200	44	200	Ø100	20	M24	30	244	15000
25160	M24x225	44	225	Ø100	20	M24	30	269	15000
25162	M24x250	44	250	Ø100	20	M24	30	294	15000
25180	M30X100	44	100	Ø100	26	M30	30	144	15000
25182	M30X125	44	125	Ø100	26	M30	30	169	15000
25184	M30X150	44	150	Ø100	26	M30	30	194	15000
25186	M30X175	44	175	Ø100	26	M30	30	219	15000
25188	M30X200	44	200	Ø100	26	M30	30	244	15000
25200	M30X225	44	225	Ø100	26	M30	30	269	15000
25202	M30X250	44	250	Ø100	26	M30	30	294	15000

CODE	description	Main Dimension							Static load Newton
		A	B	D	CH	F	G	H1	
25020	M16X75	35	75	Ø80	13	M16	25	110	10000
25022	M16X100	35	100	Ø80	13	M16	25	135	10000
25024	M16X125	35	125	Ø80	13	M16	25	160	10000
25026	M16X150	35	150	Ø80	13	M16	25	185	10000
25028	M16X175	35	175	Ø80	13	M16	25	210	10000
25040	M20X75	38	75	Ø80	17	M20	25	113	10000
25042	M20X100	38	100	Ø80	17	M20	25	138	10000
25044	M20X125	38	125	Ø80	17	M20	25	163	10000
25046	M20X150	38	150	Ø80	17	M20	25	188	10000
25048	M20X175	38	175	Ø80	17	M20	25	213	10000
25050	M20X200	38	200	Ø80	17	M20	25	238	10000
25052	M20X225	38	225	Ø80	17	M20	25	260	10000
25070	M24X75	40	75	Ø80	20	M24	25	115	10000
25072	M24x100	40	100	Ø80	20	M24	25	140	10000
25074	M24x125	40	125	Ø80	20	M24	25	165	10000
25076	M24x150	40	150	Ø80	20	M24	25	190	10000
25078	M24x175	40	175	Ø80	20	M24	25	215	10000
25080	M24x200	40	200	Ø80	20	M24	25	240	10000
25082	M24x225	40	225	Ø80	20	M24	25	265	10000

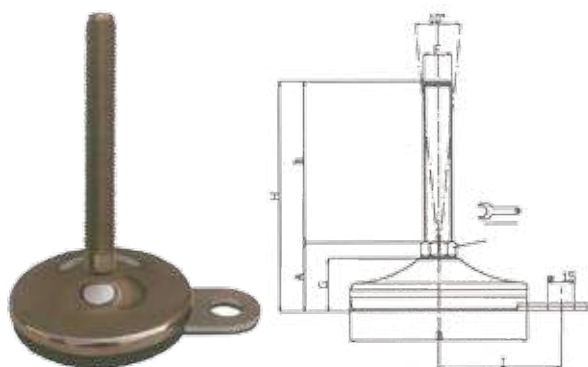

CODE	description	Main Dimension								Static load Newton
		A	B	D	CH	F	G	H1	I	
24900/10/F	M10X50	35	50	Ø80	14	M10	25	85	54	10000
25000/10/F	M10X75	35	75	Ø80	14	M10	25	110	54	10000
25002/10/F	M10X100	35	100	Ø80	14	M10	25	135	54	10000
25004/10/F	M10X125	35	125	Ø80	14	M10	25	160	54	10000
24900/12/F	M12X50	35	50	Ø80	14	M12	25	85	54	10000
25000/12/F	M12X75	35	75	Ø80	14	M12	25	110	54	10000
25002/12/F	M12X100	35	100	Ø80	14	M12	25	135	54	10000
25004/12/F	M12X125	35	125	Ø80	14	M12	25	160	54	10000
25006/12/F	M12X150	35	150	Ø80	14	M12	25	185	54	10000
25000/F	M14X75	35	75	Ø80	14	M14	25	110	54	10000
25002/F	M14X100	35	100	Ø80	14	M14	25	135	54	10000
25004/F	M14X125	35	125	Ø80	14	M14	25	160	54	10000
25006/F	M14X150	35	150	Ø80	14	M14	25	185	54	10000
25008/F	M14X175	35	175	Ø80	14	M14	25	210	54	10000

CODE	description	Main Dimension								Static load Newton
		A	B	D	CH	F	G	H	I	
25100/F	M16X75	39,5	75	Ø100	13	M16	30	114,5	69	15000
25102/F	M16X100	39,5	100	Ø100	13	M16	30	139,5	69	15000
25104/F	M16X125	39,5	125	Ø100	13	M16	30	164,5	69	15000
25106/F	M16X150	39,5	150	Ø100	13	M16	30	189,5	69	15000
25108/F	M16X175	39,5	175	Ø100	13	M16	30	214,5	69	15000
25110/F	M16X200	39,5	200	Ø100	13	M16	30	239,5	69	15000
25120/F	M20X75	43	75	Ø100	13	M20	30	118	69	15000
25122/F	M20X100	43	100	Ø100	13	M20	30	143	69	15000
25124/F	M20X125	43	125	Ø100	13	M20	30	168	69	15000
25126/F	M20X150	43	150	Ø100	13	M20	30	193	69	15000
25128/F	M20X175	43	175	Ø100	13	M20	30	218	69	15000
25130/F	M20X200	43	200	Ø100	13	M20	30	243	69	15000
25132/F	M20X225	43	225	Ø100	13	M20	30	268	69	15000
25134/F	M20X250	43	250	Ø100	13	M20	30	293	69	15000

CODE	description	Main Dimension					
		D	D1	H	H1	G	F
30000E/27	Volantino D27 M5	27	15	19	10	10	M5
30010E/33	Volantino D33 M6	33	19	23	12	12	M6
30020E/40	Volantino D40 M8	40	21	27	15	13	M8
30030E/50	Volantino D50 M10	50	25	33	17,5	17	M10
30040E/60	Volantino D60 M12	60	27	37	20	20	M12

Stainless steel knobs - Female

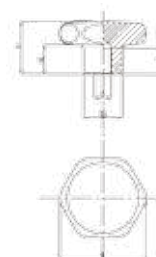

CODE	description	Main Dimension					
		D	D1	H	H1	G	F
30060E/27	Volantino D27 M6	27	15	30	10	10	M6
30070E/33	Volantino D33 M8	33	19	43	11	20	M8
30080E/40	Volantino D40 M8	40	21	47	15	20	M8
30090E/50	Volantino D50 M10	50	25	63	17,5	30	M10
30100E/60	Volantino D60 M12	60	27	77	20	40	M12

Stainless steel knobs - Male

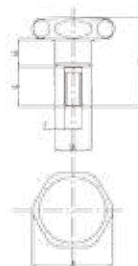

CODE	description	Main Dimension						
		A	B	I	I1	F	H	H1
60000	Cerniera inox 38X38	38	38	23	23	5	4	9
60010	Cerniera inox 50X50	50	50	33	33	5	4	9

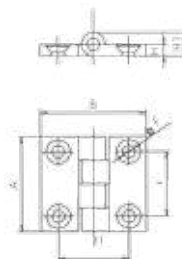

CODE	description	Main Dimension							
		A	B	I	I1	I2	F	H	H1
60012	Cerniera inox 40X58	40	58	20	24	16	5	4	9,5
60014	Cerniera inox 38X73	38	73	21	32	25,5	5	4	9,5

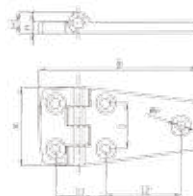

Subject to printer's error and products which are no longer in our program.  
ScanBelt / ScanBelt Nordic reserves the right to make changes without prior notice.

ScanBelt Nordic stocks a wide range of timing belts in both PU and rubber manufactured by Megadyne. We are also able to deliver special belts with holes and special types of coating.

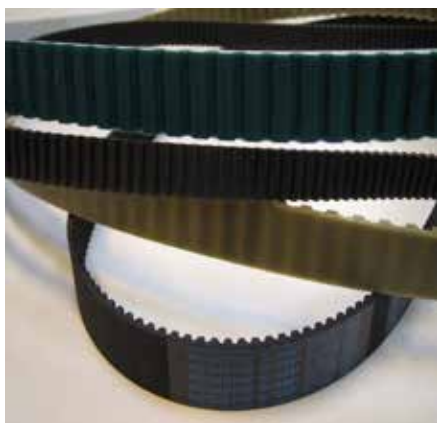
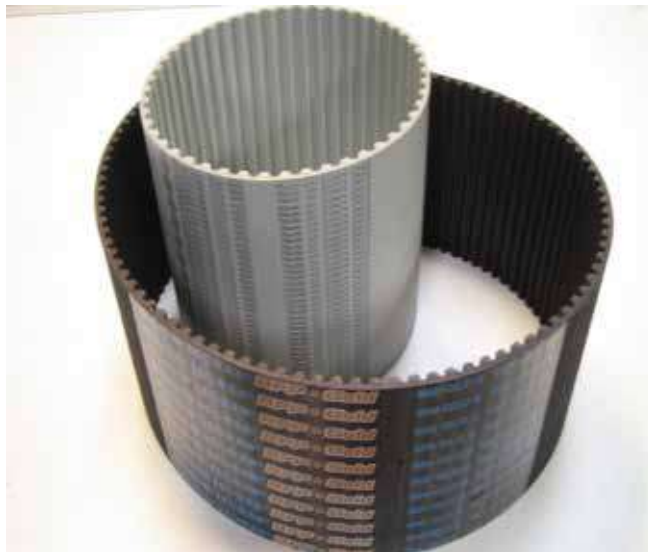



## MEGAPOWER PU endless timing belts

T2	
Std. width (mm)	
4/6/8/10/12	

T2	
Code	Pitch length (mm)
180	180
200	200
288	288
P	2
H	1,1
H <sub>i</sub>	0,5

T2.5	
Std. width (mm)	
4/6/8/10/12	

T2.5	
Code	Pitch length (mm)
120	120
145	145
160	160
177,5	177,5
180	180
182,5	182,5
200	200
210	210
230	230
245	245
265	265
277,5	277,5
285	285
290	290
305	305
317,5	317,5
330	330
342,5	342,5
380	380
420	420
480	480
500	500
540	540
600	600
620	620
650	650
680	680
700	700
780	780
880	880
915	915
950	950
1185	1185
P	2,5
H	1,3
H <sub>i</sub>	0,7

T5	
Std. width (mm)	
6/8/10/12/16/20/25	

T5	
Code	Pitch length (mm)
120	120
150	150
165	165
180	180
185	185
200	200
210	210
215	215
220	220
225	225
245	245
250	250
255	255
260	260
270	270
275	275
280	280
295	295
300	300
305	305
330	330
340	340
350	350
355	355
365	365
375	375
390	390
395	395
400	400
410	410
420	420
425	425
440	440
445	445
450	450
455	455
460	460
475	475
480	480
500	500
510	510
515	515
515*	515*
525	525
545	545
550	550
560	560
560*	560*
575	575
590	590
600	600
610	610
620	620
630	630
640	640
650	650
660	660
675	675
690	690
700	700
720	720
725	725
750	750
765	765
780	780
800	800
815	815
830	830
840	840
850	850
860	860
885	885
900	900
920	920
940	940
990	990
1075	1075
1100	1100
1160	1160
1200	1200
1215	1215
1275	1275
1280	1280
1315	1315
1355	1355
1380	1380
1440	1440
1470	1470
1500	1500
1580	1580
1955	1955
P	5
H	2,2
H <sub>i</sub>	1,2

T10	
Std. width (mm)	
10/12/16/20/25/32/50/75	

T10	
Code	Pitch length (mm)
260	260
320	320
340	340
370	370
390	390
400	400
410	410
440	440
450	450
480	480
500	500
530	530
550	550
560	560
600	600
600*	600*
610	610
630	630
630*	630*
650	650
660	660
680	680
690	690
700	700
720	720
720*	720*
730	730
750	750
780	780
800*	800*
810	810
840	840
850	850
880	880
890	890
900	900
900*	900*
910	910
920	920
920*	920*
950	950
960	960
970	970
980	980
1000	1000
1010	1010
1050	1050
1080	1080
1100	1100
1110	1110
1140	1140
1150	1150
1200	1200
1210	1210
1240	1240
1250	1250
1300	1300
1320	1320
1350	1350
1390	1390
1400	1400
1420	1420
1440	1440
1450	1450
1460	1460
1500	1500
1560	1560
1600	1600
1610	1610
1700	1700
1750	1750
1780	1780
1880	1880
1960	1960
2250	2250
P	10
H	4,5
H <sub>i</sub>	2,5

T2.5 DD	
Std. width (mm)	
4/6/8/10/12	

T2.5 DD	
Code	Pitch length (mm)
457,5 DD	457,5
P	2,5
H	1,3
H <sub>i</sub>	0,7

T5 DD	
Std. width (mm)	
6/8/10/12/16/20/25	

T5 DD	
Code	Pitch length (mm)
410 DD	410
460 DD	460
515 DD	515
525 DD	525
550 DD	550
590 DD	590
620 DD	620
685 DD	685
700 DD	700
750 DD	750
815 DD	815
840 DD	840
860 DD	860
940 DD	940
1100 DD	1100
P	5
H	2,2
H <sub>i</sub>	1,2

T10 DD	
Std. width (mm)	
10/12/16/20/25/32/50/75	

T10 DD	
Code	Pitch length (mm)
260 DD	260
530 DD	530
630 DD	630
660 DD	660
700 DD	700
720 DD	720
800 DD	800
840 DD	840
900 DD	900
920 DD	920
980 DD	980
1010 DD	1010
1100 DD	1100
1150 DD	1150
1210 DD	1210
1240 DD	1240
1250 DD	1250
1320 DD	1320
1350 DD	1350
1420 DD	1420
1610 DD	1610
1880 DD	1880
P	10
H	4,5
H <sub>i</sub>	2,5

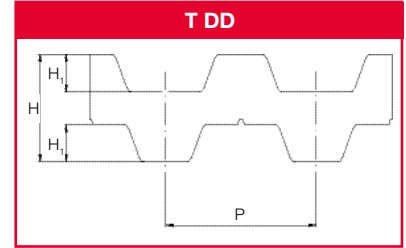
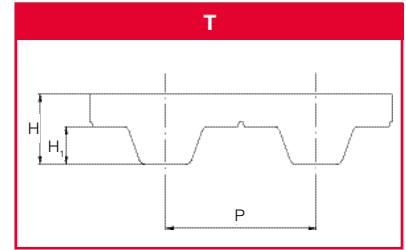

**MEGAPOWER**  
**PU endless timing belts**

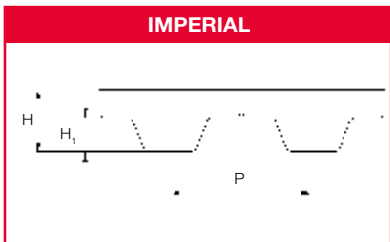
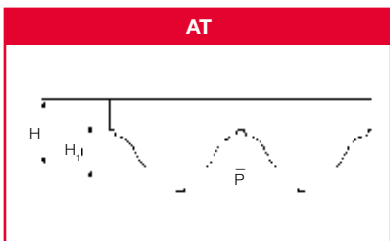

<b>AT5</b>	
Std. width (mm)	
6/8/10/12/16/20/25	

<b>AT5</b>	
Code	Pitch length (mm)
225	225
255	255
275	275
280	280
300	300
330	330
340	340
375	375
390	390
420	420
450	450
455	455
480	480
500	500
525	525
545	545
600	600
610	610
620	620
630	630
660	660
670	670
710	710
720	720
750	750
780	780
825	825
860	860
975	975
1050	1050
1125	1125
1500	1500
2000	2000
P	5
H	2,7
H <sub>1</sub>	1,2

<b>AT10</b>	
Std. width (mm)	
10/12/16/20/25/32/50/75	

<b>AT10</b>	
Code	Pitch length (mm)
370	370
500	500
560	560
580	580
600	600
610	610
630	630
660	660
700	700
730	730
780	780
800	800
810	810
840	840
880	880
890	890
920	920
960	960
980	980
1000	1000
1010	1010
1050	1050
1080	1080
1100	1100
1150	1150
1190	1190
1200	1200
1210	1210
1220	1220
1230	1230
1240	1240
1250	1250
1280	1280
1300	1300
1320	1320
1350	1350
1360	1360
1400	1400
1420	1420
1480	1480
1500	1500
1600	1600
1630	1630
1700	1700
1720	1720
1800	1800
1860	1860
1940	1940
P	10
H	4,5
H <sub>1</sub>	2,5

<b>MXL</b>	
Std. width (mm)	
3,2/4,8/6,4	

<b>MXL</b>	
Code	Pitch length (mm)
44	111,7
45,6	115,8
48	121,9
56	142,2
57,6	146,3
60	152,4
60,8	154,4
63,2	160,5
64	162,5
65,6	166,6
70,4	178,8
72,8	184,9
73,6	186,9
76,8	195,1
80,8	205,2
81,6	207,2
82,4	209,2
84	213,3
88	223,5
91,2	231,6
94,4	239,7
96	243,8
104	264,1
105,6	268,2
108	274,3
112	284,4
116	294,6
120	304,8
124	314,9
140	355,6
152	386,5
160	406,8
176,8	449,1
204,8	520,1
224	568,9
228	579,1
246,4	625,8
265,6	674,6
281,6	715,2
288	731,5
316	802,6
324	822,9
329,6	837,1
345,6	877,8
363,2	922,5
388	985,5
P	2,032
H	1,2
H <sub>1</sub>	0,51

<b>XL</b>	
Std. width (mm)	
6,4/7,9/9,4	

<b>XL</b>	
Code	Pitch length (mm)
60	152,4
70	177,8
76	193,0
80	203,2
90	228,6
100	254,0
110	279,4
120	304,8
130	330,2
134	340,3
140	355,6
150	381,0
160	406,4
170	431,8
180	457,2
190	482,6
194	492,7
200	508,0
210	533,4
220	558,8
230	584,2
240	609,6
250	635,0
260	660,4
270	685,8
288	731,5
290	736,6
300	762,0
356	904,2
414	1051,5
450	1143,0
566	1437,6
P	5,08
H	2,3
H <sub>1</sub>	1,7

<b>L</b>	
Std. width (mm)	
12,7/19,1/25,4	

<b>L</b>	
Code	Pitch length (mm)
86	218,6
124	314,3
150	381,0
173	438,1
187	476,2
202	514,4
210	533,4
225	571,5
240	609,6
255	647,7
270	685,8
285	723,9
300	762,0
322	817,9
345	876,3
367	933,4
390	990,6
420	1066,8
450	1143,0
480	1219,2
510	1295,4
540	1371,6
570	1447,8
600	1524,0
P	9,525
H	3,6
H <sub>1</sub>	1,9

<b>H</b>	
Std. width (mm)	
19,1/25,4/38,1/50,8/76,2	

<b>H</b>	
Code	Pitch length (mm)
230	584,2
240	609,6
270	685,8
300	762,0
330	838,2
360	914,4
390	990,6
420	1066,8
450	1143,0
480	1219,2
510	1295,4
P	12,7
H	4,3
H <sub>1</sub>	2,29

Ø 50  
Part. 7

Timing belts

# ISORAN

## Rubber endless timing belts

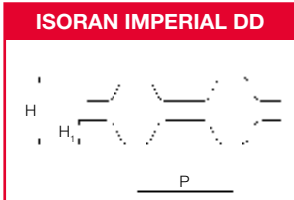
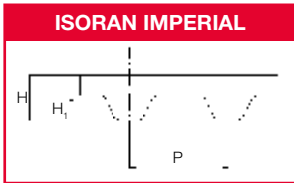

MXL	
Code	Pitch length (mm)
360 MXL	91,44
432 MXL	109,73
440 MXL	111,76
456 MXL	115,82
480 MXL	121,92
488 MXL	123,95
496 MXL	125,98
536 MXL	136,14
544 MXL	138,18
576 MXL	146,30
584 MXL	148,34
608 MXL	154,43
632 MXL	160,53
640 MXL	162,56
656 MXL	166,62
664 MXL	168,66
680 MXL	172,72
704 MXL	178,82
720 MXL	182,88
736 MXL	186,94
752 MXL	191,00
760 MXL	193,04
776 MXL	197,10
800 MXL	203,20
808 MXL	205,23
824 MXL	209,30
840 MXL	213,36
880 MXL	223,52
888 MXL	225,55
912 MXL	231,65
920 MXL	233,68
944 MXL	239,78
952 MXL	241,81
960 MXL	243,84
976 MXL	247,90
984 MXL	249,94
1000 MXL	254,00
1008 MXL	256,03
1016 MXL	258,06
1040 MXL	264,16
1056 MXL	268,22
1072 MXL	272,29
1120 MXL	284,48
1160 MXL	294,64
1176 MXL	298,70
1184 MXL	300,74
1200 MXL	304,80
1224 MXL	310,90
1280 MXL	325,12
1400 MXL	355,60
1472 MXL	373,89
1496 MXL	379,98
1520 MXL	386,08
1600 MXL	406,40
1680 MXL	426,72
1696 MXL	430,78
1768 MXL	449,07
1800 MXL	457,20
1832 MXL	465,33
1856 MXL	471,42
1888 MXL	479,55
1984 MXL	503,94
1992 MXL	505,97
2048 MXL	520,19
2240 MXL	568,96
2360 MXL	599,44
2384 MXL	605,54
2480 MXL	629,92
2496 MXL	633,98
2520 MXL	640,08
2584 MXL	656,34
2776 MXL	705,10
2864 MXL	727,46
2880 MXL	731,52
2976 MXL	755,90
3064 MXL	778,26
3104 MXL	788,42
3200 MXL	812,80
3296 MXL	837,18
3424 MXL	869,70
3472 MXL	881,89
3480 MXL	883,92
3520 MXL	894,08
3632 MXL	922,53
3704 MXL	940,82
3944 MXL	1001,78
4000 MXL	1016,00
4064 MXL	1032,26
4200 MXL	1066,80
4280 MXL	1087,12
<b>P</b>	<b>2,032</b>
<b>H<sub>1</sub></b>	<b>0,51</b>
<b>H</b>	<b>1,14</b>

MXL	
Code	Pitch length (mm)
4320 MXL	1097,28
4456 MXL	1131,82
4736 MXL	1202,94
4800 MXL	1219,20
5224 MXL	1326,90
<b>P</b>	<b>2,032</b>
<b>H<sub>1</sub></b>	<b>0,51</b>
<b>H</b>	<b>1,14</b>

XL	
Code	Pitch length (mm)
54 XL	137,16
60 XL	152,40
70 XL	177,80
80 XL	203,20
90 XL	228,60
98 XL	248,92
100 XL	254,00
102 XL	259,08
104 XL	264,16
106 XL	269,24
110 XL	279,40
120 XL	304,80
130 XL	330,20
140 XL	355,60
146 XL	370,84
150 XL	381,00
156 XL	396,24
160 XL	406,40
170 XL	431,80
176 XL	447,04
180 XL	457,20
182 XL	462,28
188 XL	477,52
190 XL	482,60
198 XL	502,92
200 XL	508,00
202 XL	513,08
210 XL	533,40
212 XL	538,48
214 XL	543,56
220 XL	558,80
228 XL	579,12
230 XL	584,20
234 XL	594,36
240 XL	609,60
250 XL	635,00
260 XL	660,40
270 XL	685,80
276 XL	701,04
290 XL	736,60
310 XL	787,40
316 XL	802,64
320 XL	812,80
330 XL	838,20
344 XL	873,76
352 XL	894,08
364 XL	924,56
380 XL	965,20
384 XL	975,36
388 XL	985,52
390 XL	990,60
392 XL	995,68
434 XL	1102,36
460 XL	1168,40
530 XL	1346,20
600 XL	1524,00
710 XL	1803,40
<b>P</b>	<b>5,08</b>
<b>H<sub>1</sub></b>	<b>1,27</b>
<b>H</b>	<b>2,4</b>

L	
Code	Pitch length (mm)
124 L	314,96
135 L	342,90
150 L	381,00
173 L	439,42
187 L	476,25
202 L	513,80
210 L	533,40
225 L	571,50
240 L	609,60
255 L	647,70
270 L	685,80
285 L	723,90
300 L	762,00
322 L	819,15
334 L	848,36
345 L	876,30
367 L	933,45
390 L	990,60
405 L	1028,70
412 L	1047,75
420 L	1066,80
450 L	1143,00
480 L	1219,20
510 L	1295,40
540 L	1371,60
600 L	1524,00
728 L	1847,85
817 L	2076,45
<b>P</b>	<b>9,525</b>
<b>H<sub>1</sub></b>	<b>1,91</b>
<b>H</b>	<b>3,6</b>

XL DD	
Code	Pitch length (mm)
DD 120 XL	304,80
DD 130 XL	330,20
DD 140 XL	355,60
DD 146 XL	370,84
DD 150 XL	381,00
DD 156 XL	396,24
DD 160 XL	406,40
DD 170 XL	431,80
DD 176 XL	447,04
DD 180 XL	457,20
DD 182 XL	462,28
DD 188 XL	477,52
DD 190 XL	482,60
DD 198 XL	502,92
DD 200 XL	508,00
DD 202 XL	513,08
DD 210 XL	533,40
DD 212 XL	538,48
DD 214 XL	543,56
DD 220 XL	558,80
DD 228 XL	579,12
DD 230 XL	584,20
DD 234 XL	594,36
DD 240 XL	609,60
DD 250 XL	635,00
DD 260 XL	660,40
DD 270 XL	685,80
DD 276 XL	701,04
DD 290 XL	736,60
DD 310 XL	787,40
DD 316 XL	802,64
DD 320 XL	812,80
DD 330 XL	838,20
DD 344 XL	873,76
DD 352 XL	894,08
DD 364 XL	924,56
DD 380 XL	965,20
DD 384 XL	975,36
DD 388 XL	985,52
DD 390 XL	990,60
DD 392 XL	995,68
DD 434 XL	1102,36
DD 460 XL	1168,40
DD 530 XL	1346,20
DD 600 XL	1524,00
DD 710 XL	1803,40
<b>P</b>	<b>5,08</b>
<b>H<sub>1</sub></b>	<b>1,27</b>
<b>H</b>	<b>3,05</b>

H	
Code	Pitch length (mm)
240 H	609,60
270 H	685,80
300 H	762,00
330 H	838,00
360 H	914,40
390 H	990,60
420 H	1066,80
450 H	1143,00
480 H	1219,20
510 H	1295,40
540 H	1371,60
570 H	1447,80
600 H	1524,00
630 H	1600,20
660 H	1676,40
670 H	1701,80
700 H	1778,00
725 H	1841,50
750 H	1905,00
800 H	2032,00
850 H	2159,00
900 H	2286,00
1000 H	2540,00
1100 H	2794,00
1120 H	2844,80
1140 H	2895,60
1150 H	2921,00
1250 H	3175,00
1400 H	3556,00
1645 H	4178,30
1700 H	4318,00
<b>P</b>	<b>12,7</b>
<b>H<sub>1</sub></b>	<b>2,29</b>
<b>H</b>	<b>4,4</b>

L DD	
Code	Pitch length (mm)
DD 124 L	314,96
DD 135 L	342,90
DD 150 L	381,00
DD 173 L	439,42
DD 187 L	474,98
DD 202 L	513,08
DD 210 L	533,40
DD 225 L	571,50
DD 240 L	609,60
DD 255 L	647,70
DD 270 L	685,80
DD 285 L	723,90
DD 300 L	762,00
DD 322 L	817,88
DD 334 L	848,36
DD 345 L	876,30
DD 367 L	932,18
DD 390 L	990,60
DD 405 L	1028,70
DD 412 L	1046,48
DD 420 L	1066,80
DD 450 L	1143,00
DD 480 L	1219,20
DD 510 L	1295,40
DD 540 L	1371,60
DD 600 L	1524,00
DD 728 L	1849,12
DD 817 L	2075,18
<b>P</b>	<b>9,525</b>
<b>H<sub>1</sub></b>	<b>1,91</b>
<b>H</b>	<b>4,6</b>

XH	
Code	Pitch length (mm)
507 XH	1289,00
534 XH	1356,36
560 XH	1422,40
630 XH	1600,20
700 XH	1778,00
770 XH	1955,80
840 XH	2133,60
980 XH	2489,20
1120 XH	2844,80
1260 XH	3200,40
1400 XH	3566,00
1540 XH	3911,60
1750 XH	4445,00
<b>P</b>	<b>22,225</b>
<b>H<sub>1</sub></b>	<b>6,22</b>
<b>H</b>	<b>11,4</b>

XXH	
Code	Pitch length (mm)
700 XXH	1778,00
800 XXH	2032,00
900 XXH	2286,00
1000 XXH	2540,00
1200 XXH	3048,00
1400 XXH	3556,00
1600 XXH	4064,00
1800 XXH	4572,00
<b>P</b>	<b>31,75</b>
<b>H<sub>1</sub></b>	<b>9,53</b>
<b>H</b>	<b>15,3</b>

H DD	
Code	Pitch length (mm)
DD 240 H	609,60
DD 270 H	685,80
DD 300 H	762,00
DD 330 H	838,20
DD 360 H	914,40
DD 390 H	990,60
DD 420 H	1066,80
DD 450 H	1143,00
DD 480 H	1219,20
DD 510 H	1295,40
DD 540 H	1371,60
DD 570 H	1447,80
DD 600 H	1524,00
DD 630 H	1600,20
DD 660 H	1676,40
DD 670 H	1701,80
DD 700 H	1778,00
DD 725 H	1841,50
DD 750 H	1905,00
DD 800 H	2032,00
DD 850 H	2159,00
DD 900 H	2286,00
DD 1000 H	2540,00
DD 1100 H	2794,00
DD 1120 H	2844,80
DD 1140 H	2895,60
DD 1150 H	2921,00
DD 1250 H	3175,00
DD 1400 H	3556,00
DD 1645 H	4178,30
DD 1700 H	4318,00
<b>P</b>	<b>12,7</b>
<b>H<sub>1</sub></b>	<b>2,29</b>
<b>H</b>	<b>5,9</b>

# ISORAN Rubber endless timing belts

RPP3	
Code	Pitch length (mm)
90 RPP3	90
105 RPP3	105
129 RPP3	129
141 RPP3	141
144 RPP3	144
147 RPP3	147
150 RPP3	150
159 RPP3	159
168 RPP3	168
174 RPP3	174
177 RPP3	177
180 RPP3	180
186 RPP3	186
195 RPP3	195
201 RPP3	201
204 RPP3	204
210 RPP3	210
213 RPP3	213
225 RPP3	225
231 RPP3	231
240 RPP3	240
243 RPP3	243
246 RPP3	246
249 RPP3	249
252 RPP3	252
255 RPP3	255
261 RPP3	261
264 RPP3	264
267 RPP3	267
270 RPP3	270
276 RPP3	276
285 RPP3	285
288 RPP3	288
291 RPP3	291
297 RPP3	297
300 RPP3	300
312 RPP3	312
318 RPP3	318
327 RPP3	327
330 RPP3	330
333 RPP3	333
336 RPP3	336
339 RPP3	339
345 RPP3	345
351 RPP3	351
357 RPP3	357
363 RPP3	363
375 RPP3	375
384 RPP3	384
390 RPP3	390
393 RPP3	393
405 RPP3	405
420 RPP3	420
432 RPP3	432
447 RPP3	447
474 RPP3	474
480 RPP3	480
486 RPP3	486
489 RPP3	489
495 RPP3	495
501 RPP3	501
510 RPP3	510
513 RPP3	513
522 RPP3	522
531 RPP3	531
537 RPP3	537
564 RPP3	564
570 RPP3	570
576 RPP3	576
579 RPP3	579
582 RPP3	582
597 RPP3	597
600 RPP3	600
633 RPP3	633
648 RPP3	648
669 RPP3	669
711 RPP3	711
735 RPP3	735
738 RPP3	738
756 RPP3	756
804 RPP3	804
882 RPP3	882
945 RPP3	945
1062 RPP3	1062
1125 RPP3	1125
1245 RPP3	1245
1263 RPP3	1263
1500 RPP3	1500
1530 RPP3	1530
1863 RPP3	1863
P	3
H <sub>1</sub>	1,15
H	2,4

RPP5	
Code	Pitch length (mm)
180 RPP5	180
225 RPP5	225
235 RPP5	235
245 RPP5	245
255 RPP5	255
265 RPP5	265
270 RPP5	270
280 RPP5	280
285 RPP5	285
295 RPP5	295
300 RPP5	300
305 RPP5	305
325 RPP5	325
330 RPP5	330
345 RPP5	345
350 RPP5	350
375 RPP5	375
400 RPP5	400
420 RPP5	420
425 RPP5	425
450 RPP5	450
455 RPP5	455
460 RPP5	460
465 RPP5	465
475 RPP5	475
500 RPP5	500
525 RPP5	525
535 RPP5	535
565 RPP5	565
575 RPP5	575
580 RPP5	580
600 RPP5	600
610 RPP5	610
615 RPP5	615
635 RPP5	635
640 RPP5	640
670 RPP5	670
675 RPP5	675
700 RPP5	700
705 RPP5	705
710 RPP5	710
725 RPP5	725
740 RPP5	740
750 RPP5	750
755 RPP5	755
800 RPP5	800
835 RPP5	835
850 RPP5	850
890 RPP5	890
900 RPP5	900
935 RPP5	935
940 RPP5	940
950 RPP5	950
980 RPP5	980
1000 RPP5	1000
1025 RPP5	1025
1050 RPP5	1050
1100 RPP5	1100
1125 RPP5	1125
1135 RPP5	1135
1195 RPP5	1195
1200 RPP5	1200
1240 RPP5	1240
1270 RPP5	1270
1420 RPP5	1420
1500 RPP5	1500
1595 RPP5	1595
1605 RPP5	1605
1690 RPP5	1690
1790 RPP5	1790
1800 RPP5	1800
1870 RPP5	1870
1895 RPP5	1895
1945 RPP5	1945
2000 RPP5	2000
2250 RPP5	2250
2525 RPP5	2525
P	5
H <sub>1</sub>	2
H	3,8

RPP8	
Code	Pitch length (mm)
248 RPP8	248
288 RPP8	288
320 RPP8	320
352 RPP8	352
360 RPP8	360
376 RPP8	376
384 RPP8	384
408 RPP8	408
416 RPP8	416
424 RPP8	424
456 RPP8	456
480 RPP8	480
536 RPP8	536
544 RPP8	544
560 RPP8	560
600 RPP8	600
608 RPP8	608
632 RPP8	632
640 RPP8	640
680 RPP8	680
720 RPP8	720
760 RPP8	760
800 RPP8	800
840 RPP8	840
880 RPP8	880
896 RPP8	896
920 RPP8	920
960 RPP8	960
1000 RPP8	1000
1040 RPP8	1040
1080 RPP8	1080
1120 RPP8	1120
1160 RPP8	1160
1200 RPP8	1200
1224 RPP8	1224
1280 RPP8	1280
1352 RPP8	1352
1424 RPP8	1424
1440 RPP8	1440
1464 RPP8	1464
1600 RPP8	1600
1680 RPP8	1680
1760 RPP8	1760
1792 RPP8	1792
1800 RPP8	1800
1904 RPP8	1904
2000 RPP8	2000
2200 RPP8	2200
2240 RPP8	2240
2272 RPP8	2272
2400 RPP8	2400
2520 RPP8	2520
2600 RPP8	2600
2800 RPP8	2800
3048 RPP8	3048
3200 RPP8	3200
3280 RPP8	3280
3600 RPP8	3600
4000 RPP8	4000
4400 RPP8	4400
P	8
H <sub>1</sub>	3,2
H	5,4

RPP14	
Code	Pitch length (mm)
2450 RPP14	2450
2520 RPP14	2520
2590 RPP14	2590
2660 RPP14	2660
2800 RPP14	2800
2968 RPP14	2968
3136 RPP14	3136
3150 RPP14	3150
3304 RPP14	3304
3360 RPP14	3360
3500 RPP14	3500
3850 RPP14	3850
3920 RPP14	3920
4326 RPP14	4326
4410 RPP14	4410
4578 RPP14	4578
4956 RPP14	4956
P	14
H <sub>1</sub>	6
H	9,7

RPP5 DD	
Code	Pitch length (mm)
600 RPP5 DD	600
610 RPP5 DD	610
615 RPP5 DD	615
635 RPP5 DD	635
640 RPP5 DD	640
670 RPP5 DD	670
675 RPP5 DD	675
700 RPP5 DD	700
705 RPP5 DD	705
710 RPP5 DD	710
725 RPP5 DD	725
740 RPP5 DD	740
750 RPP5 DD	750
755 RPP5 DD	755
800 RPP5 DD	800
835 RPP5 DD	835
850 RPP5 DD	850
890 RPP5 DD	890
900 RPP5 DD	900
935 RPP5 DD	935
940 RPP5 DD	940
950 RPP5 DD	950
980 RPP5 DD	980
1000 RPP5 DD	1000
1025 RPP5 DD	1025
1050 RPP5 DD	1050
1100 RPP5 DD	1100
1125 RPP5 DD	1125
1135 RPP5 DD	1135
1195 RPP5 DD	1195
1200 RPP5 DD	1200
1240 RPP5 DD	1240
1270 RPP5 DD	1270
1420 RPP5 DD	1420
1500 RPP5 DD	1500
1595 RPP5 DD	1595
1605 RPP5 DD	1605
1690 RPP5 DD	1690
1790 RPP5 DD	1790
1800 RPP5 DD	1800
1870 RPP5 DD	1870
1895 RPP5 DD	1895
1945 RPP5 DD	1945
2000 RPP5 DD	2000
2250 RPP5 DD	2250
2525 RPP5 DD	2525
P	5
H <sub>1</sub>	2
H	5,2

  

RPP8DD	
Code	Pitch length (mm)
600 RPP8 DD	600
608 RPP8 DD	608
632 RPP8 DD	632
640 RPP8 DD	640
680 RPP8 DD	680
720 RPP8 DD	720
800 RPP8 DD	800
840 RPP8 DD	840
880 RPP8 DD	880
896 RPP8 DD	896
920 RPP8 DD	920

RPP8DD	
Code	Pitch length (mm)
960 RPP8 DD	960
1000 RPP8 DD	1000
1040 RPP8 DD	1040
1080 RPP8 DD	1080
1120 RPP8 DD	1120
1200 RPP8 DD	1200
1224 RPP8 DD	1224
1280 RPP8 DD	1280
1352 RPP8 DD	1352
1424 RPP8 DD	1424
1440 RPP8 DD	1440
1464 RPP8 DD	1464
1600 RPP8 DD	1600
1680 RPP8 DD	1680
1760 RPP8 DD	1760
1800 RPP8 DD	1800
2000 RPP8 DD	2000
2200 RPP8 DD	2200
2272 RPP8 DD	2272
2400 RPP8 DD	2400
2520 RPP8 DD	2520
2600 RPP8 DD	2600
2800 RPP8 DD	2800
3048 RPP8 DD	3048
3280 RPP8 DD	3280
3600 RPP8 DD	3600
4400 RPP8 DD	4400
1790 RPP5 DD	1790
1800 RPP5 DD	1800
1870 RPP5 DD	1870
1895 RPP5 DD	1895
1945 RPP5 DD	1945
2000 RPP5 DD	2000
2250 RPP5 DD	2250
2525 RPP5 DD	2525
P	8
H <sub>1</sub>	3,2
H	7,8

RPP14DD	
Code	Pitch length (mm)
966 RPP14 DD	966
994 RPP14 DD	994
1092 RPP14 DD	1092
1106 RPP14 DD	1106
1190 RPP14 DD	1190
1260 RPP14 DD	1260
1288 RPP14 DD	1288
1344 RPP14 DD	1344
1400 RPP14 DD	1400
1442 RPP14 DD	1442
1568 RPP14 DD	1568
1610 RPP14 DD	1610
1750 RPP14 DD	1750
1764 RPP14 DD	1764
1778 RPP14 DD	1778
1848 RPP14 DD	1848
1890 RPP14 DD	1890
1904 RPP14 DD	1904
1960 RPP14 DD	1960
2100 RPP14 DD	2100
2240 RPP14 DD	2240
2310 RPP14 DD	2310
2380 RPP14 DD	2380
2450 RPP14 DD	2450
2590 RPP14 DD	2590
2660 RPP14 DD	2660
2800 RPP14 DD	2800
2968 RPP14 DD	2968
3150 RPP14 DD	3150
3360 RPP14 DD	3360
3500 RPP14 DD	3500
3850 RPP14 DD	3850
3920 RPP14 DD	3920
4326 RPP14 DD	4326
4578 RPP14 DD	4578
4956 RPP14 DD	4956
3600 RPP8 DD	3600
4400 RPP8 DD	4400
1790 RPP5 DD	1790
1800 RPP5 DD	1800
1870 RPP5 DD	1870
1895 RPP5 DD	1895
1945 RPP5 DD	1945
2000 RPP5 DD	2000
2250 RPP5 DD	2250
2525 RPP5 DD	2525
P	14
H <sub>1</sub>	6
H	13,7

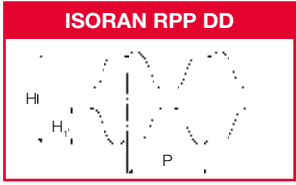
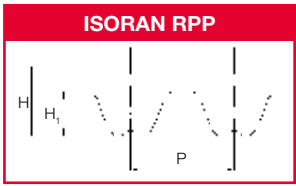

**ISORAN**  
**Rubber endless timing belts**

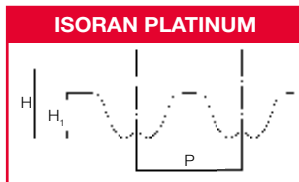
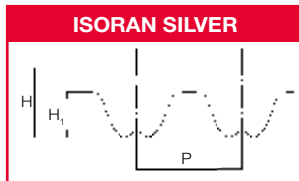
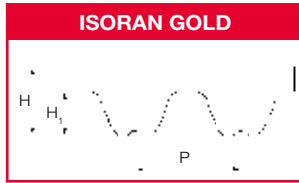

SLV5	
Code	Pitch length (mm)
180 SLV5	180
225 SLV5	225
235 SLV5	235
245 SLV5	245
255 SLV5	255
265 SLV5	265
270 SLV5	270
280 SLV5	280
285 SLV5	285
295 SLV5	295
300 SLV5	300
305 SLV5	305
325 SLV5	325
345 SLV5	345
350 SLV5	350
375 SLV5	375
400 SLV5	400
420 SLV5	420
425 SLV5	425
450 SLV5	450
455 SLV5	455
460 SLV5	460
465 SLV5	465
475 SLV5	475
500 SLV5	500
525 SLV5	525
535 SLV5	535
565 SLV5	565
575 SLV5	575
580 SLV5	580
600 SLV5	600
610 SLV5	610
615 SLV5	615
635 SLV5	635
640 SLV5	640
670 SLV5	670
675 SLV5	675
700 SLV5	700
705 SLV5	705
710 SLV5	710
725 SLV5	725
740 SLV5	740
750 SLV5	750
755 SLV5	755
800 SLV5	800
835 SLV5	835
850 SLV5	850
890 SLV5	890
900 SLV5	900
935 SLV5	935
940 SLV5	940
950 SLV5	950
980 SLV5	980
1000 SLV5	1000
1025 SLV5	1025
1050 SLV5	1050
1100 SLV5	1100
1125 SLV5	1125
1135 SLV5	1135
1195 SLV5	1195
1200 SLV5	1200
1240 SLV5	1240
1270 SLV5	1270
1420 SLV5	1420
1500 SLV5	1500
1595 SLV5	1595
1605 SLV5	1605
1690 SLV5	1690
1790 SLV5	1790
1800 SLV5	1800
1870 SLV5	1870
1895 SLV5	1895
1945 SLV5	1945
2000 SLV5	2000
2250 SLV5	2250
2525 SLV5	2525

P	5
H <sub>1</sub>	2
H	3,8

SLV8	
Code	Pitch length (mm)
248 SLV8	248
288 SLV8	288
320 SLV8	320
352 SLV8	352
360 SLV8	360
384 SLV8	384
408 SLV8	408
416 SLV8	416
456 SLV8	456
480 SLV8	480
536 SLV8	536
544 SLV8	544
560 SLV8	560
600 SLV8	600
608 SLV8	608
632 SLV8	632
640 SLV8	640
680 SLV8	680
720 SLV8	720
760 SLV8	760
800 SLV8	800
840 SLV8	840
880 SLV8	880
896 SLV8	896
920 SLV8	920
960 SLV8	960
1000 SLV8	1000
1040 SLV8	1040
1080 SLV8	1080
1120 SLV8	1120
1160 SLV8	1160
1200 SLV8	1200
1224 SLV8	1224
1280 SLV8	1280
1352 SLV8	1352
1424 SLV8	1424
1440 SLV8	1440
1464 SLV8	1464
1600 SLV8	1600
1680 SLV8	1680
1760 SLV8	1760
1800 SLV8	1800
1904 SLV8	1904
2000 SLV8	2000
2200 SLV8	2200
2240 SLV8	2240
2272 SLV8	2272
2400 SLV8	2400
2520 SLV8	2520
2600 SLV8	2600
2800 SLV8	2800
2840 SLV8	2840
3048 SLV8	3048
3200 SLV8	3200
3280 SLV8	3280
3600 SLV8	3600
4000 SLV8	4000
4400 SLV8	4400

P	8
H <sub>1</sub>	3,2
H	5,4

SLV14	
Code	Pitch length (mm)
966 SLV14	966
994 SLV14	994
1092 SLV14	1092
1106 SLV14	1106
1120 SLV14	1120
1190 SLV14	1190
1260 SLV14	1260
1288 SLV14	1288
1344 SLV14	1344
1400 SLV14	1400
1442 SLV14	1442
1568 SLV14	1568
1610 SLV14	1610
1750 SLV14	1750
1764 SLV14	1764
1778 SLV14	1778
1848 SLV14	1848
1890 SLV14	1890
1904 SLV14	1904
1960 SLV14	1960
2100 SLV14	2100
2240 SLV14	2240
2310 SLV14	2310
2380 SLV14	2380
2450 SLV14	2450
2520 SLV14	2520
2590 SLV14	2590
2660 SLV14	2660
2800 SLV14	2800
2968 SLV14	2968
3136 SLV14	3136
3150 SLV14	3150
3304 SLV14	3304
3360 SLV14	3360
3500 SLV14	3500
3850 SLV14	3850
3920 SLV14	3920
4326 SLV14	4326
4410 SLV14	4410
4578 SLV14	4578
4956 SLV14	4956

P	14
H <sub>1</sub>	6
H	9,7

PLT8	
Code	Pitch length (mm)
248 PLT8	248
288 PLT8	288
352 PLT8	352
416 PLT8	416
456 PLT8	456
480 PLT8	480
544 PLT8	544
560 PLT8	560
608 PLT8	608
640 PLT8	640
720 PLT8	720
800 PLT8	800
840 PLT8	840
896 PLT8	896
960 PLT8	960
1000 PLT8	1000
1040 PLT8	1040
1120 PLT8	1120
1224 PLT8	1224
1280 PLT8	1280
1440 PLT8	1440
1600 PLT8	1600
1760 PLT8	1760
1792 PLT8	1792
2000 PLT8	2000
2200 PLT8	2200
2240 PLT8	2240
2400 PLT8	2400
2520 PLT8	2520
2600 PLT8	2600
2800 PLT8	2800
2840 PLT8	2840
3048 PLT8	3048
3600 PLT8	3600
4000 PLT8	4000

P	8
H <sub>1</sub>	3,2
H	5,4

GLD8	
Code	Pitch length (mm)
248 GLD8	248
288 GLD8	288
320 GLD8	320
352 GLD8	352
360 GLD8	360
384 GLD8	384
408 GLD8	408
416 GLD8	416
456 GLD8	456
480 GLD8	480
536 GLD8	536
544 GLD8	544
560 GLD8	560
600 GLD8	600
608 GLD8	608
632 GLD8	632
640 GLD8	640
680 GLD8	680
720 GLD8	720
800 GLD8	800
840 GLD8	840
880 GLD8	880
896 GLD8	896
920 GLD8	920
960 GLD8	960
1000 GLD8	1000
1040 GLD8	1040
1080 GLD8	1080
1120 GLD8	1120
1160 GLD8	1160
1200 GLD8	1200
1224 GLD8	1224
1280 GLD8	1280
1352 GLD8	1352
1424 GLD8	1424
1440 GLD8	1440
1464 GLD8	1464
1600 GLD8	1600
1680 GLD8	1680
1760 GLD8	1760
1792 GLD8	1792
1800 GLD8	1800
1904 GLD8	1904
2000 GLD8	2000
2200 GLD8	2200
2240 GLD8	2240
2272 GLD8	2272
2400 GLD8	2400
2520 GLD8	2520
2600 GLD8	2600
2800 GLD8	2800
3048 GLD8	3048
3200 GLD8	3200
3280 GLD8	3280
3600 GLD8	3600
4000 GLD8	4000
4400 GLD8	4400

P	8
H <sub>1</sub>	3,2
H	5,4

PLT14	
Code	Pitch length (mm)
994 PLT14	994
1092 PLT14	1092
1120 PLT14	1120
1260 PLT14	1260
1400 PLT14	1400
1568 PLT14	1568
1610 PLT14	1610
1750 PLT14	1750
1890 PLT14	1890
1960 PLT14	1960
2100 PLT14	2100
2240 PLT14	2240
2310 PLT14	2310
2380 PLT14	2380
2450 PLT14	2450
2520 PLT14	2520
2660 PLT14	2660
2800 PLT14	2800
3136 PLT14	3136
3304 PLT14	3304
3360 PLT14	3360
3850 PLT14	3850
3920 PLT14	3920
4326 PLT14	4326
4410 PLT14	4410

P	14
H <sub>1</sub>	6
H	9,7

GLD14	
Code	Pitch length (mm)
966 GLD14	966
994 GLD14	994
1092 GLD14	1092
1106 GLD14	1106
1120 GLD14	1120
1190 GLD14	1190
1260 GLD14	1260
1288 GLD14	1288
1344 GLD14	1344
1400 GLD14	1400
1442 GLD14	1442
1568 GLD14	1568
1610 GLD14	1610
1750 GLD14	1750
1764 GLD14	1764
1778 GLD14	1778
1848 GLD14	1848
1890 GLD14	1890
1904 GLD14	1904
1960 GLD14	1960
2100 GLD14	2100
2240 GLD14	2240
2310 GLD14	2310
2380 GLD14	2380
2450 GLD14	2450
2520 GLD14	2520
2590 GLD14	2590
2660 GLD14	2660
2800 GLD14	2800
2968 GLD14	2968
3136 GLD14	3136
3150 GLD14	3150
3304 GLD14	3304
3360 GLD14	3360
3500 GLD14	3500
3850 GLD14	3850
3920 GLD14	3920
4326 GLD14	4326
4410 GLD14	4410
4578 GLD14	4578
4956 GLD14	4956

P	14
H <sub>1</sub>	6
H	9,7

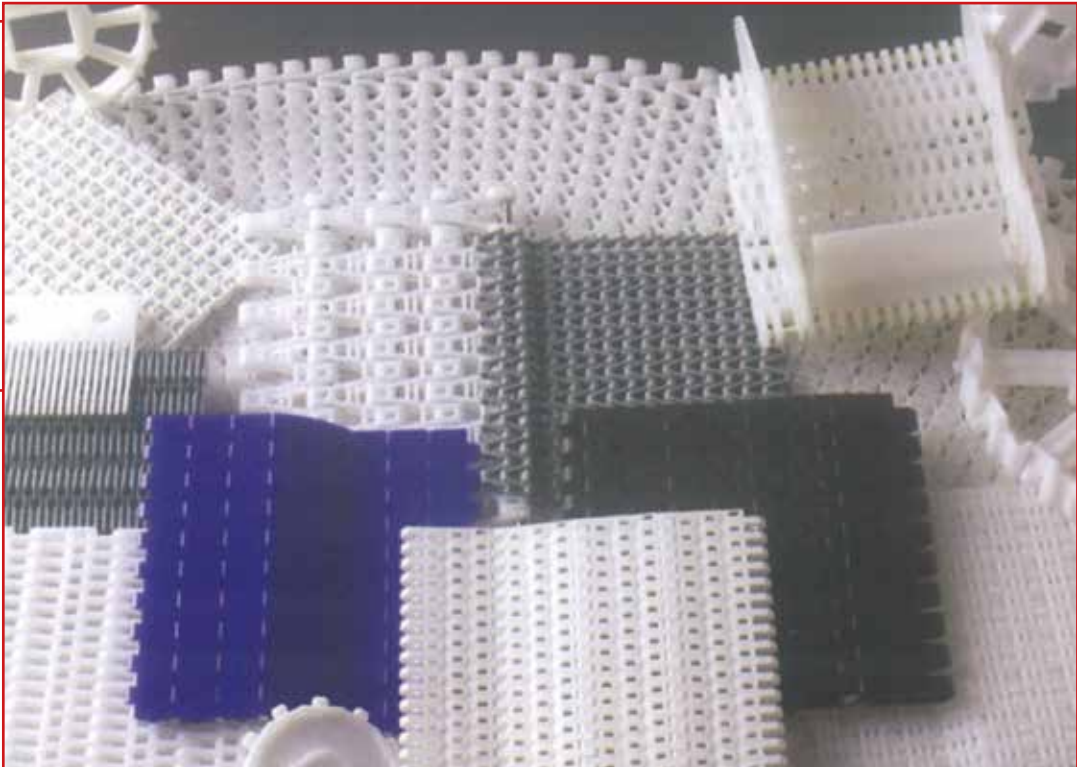

In ScanBelt Hjoerring we are producing the biggest and most flexible program of Plastic Modular Conveyor belts in the market. For further details

You are welcome to contact us for specific catalogues or brochures. The application possibilities are wellknown and endless.....



The worlds strongest plastic conveyor chains are produced in the same location in Hjoerring. These are widely used in the brewery sector for conveying crates, kegs and pallets. For more detailed information about these, please do not hesitate to request a special catalogue.



Stainless steel or normal steel roller chains including sprockets are the main components in our range of power transmission products whether this products are

all standard, with attachments or machined upon request, we are able to offer the most competitive price, highest quality and fastest delivery times.

Accessories such as chain couplings, tensioners, idler sprockets and chain breakers are also available. For specific details about these products, please request a separate catalogue featuring these products.



Our product range features numerous kinds of power transmission belts and pulleys. Standard, medium or high

performance timing belts, a complete range of V-belts, automotive belts, poly-v belts, PU belts and round belts are all offered from stock. If your requirements exceed the standard range, please do not hesitate to request a more detailed separate catalogue.

